

STANDARD UTILITY SPECIFICATIONS

TOWN OF CHAPEL HILL, TENNESSEE

HONORABLE MIKE FAULKENBERRY, MAYOR

DANNY BINGHAM, CITY ADMINISTRATOR

MARION JOYCE, VICE MAYOR

DALE BROWN, ALDERMAN

JONATHAN GILBERT, JR., ALDERMAN

DOROTHY MORTON, ALDERMAN

JOE SEDLAK, ALDERMAN

BRIAN WILLIAMS, ALDERMAN

OCTOBER 2022

Prepared By:



**THE TOWN OF CHAPEL HILL
STANDARD UTILITY SPECIFICATIONS**

APPROVALS PAGE

Engineer's Seal (Hethcoat & Davis, Inc.):



Approval, State of Tennessee, Division of Water Supply:

Approval, State of Tennessee, Division of Water Pollution Control:

TABLE OF CONTENTS

- 1.00 Policies and Procedures
 - 1.01 Purpose
 - 1.02 Definitions
 - 1.03 Standard Reference Specifications
 - 1.04 Standards for Construction Plans
 - 1.05 Design Criteria
 - A. Sanitary Sewers
 - B. Water Mains
 - C. Roadways
 - D. Drainage
 - E. Miscellaneous
 - 1.06 Review and Approval
 - 1.07 Schedule
 - 1.08 Bonds for Improvements

- 2.00 General Construction Requirements
 - 2.01 Construction Reference Standards
 - 2.02 General Project Requirements
 - 2.03 Field Engineering
 - 2.04 Shop Drawings, Product Data
 - 2.05 Temporary Controls
 - 2.06 Transportation and Handling
 - 2.07 Storage and Protection
 - 2.08 Project Closeout
 - 2.09 Project Record Documents
 - 2.10 Cleaning
 - 2.11 "Buy American" Policy

- 3.00 Civil Site
 - 3.01 Clearing
 - 3.02 Structure Excavation and Backfill
 - 3.03 Erosion Control
 - 3.04 Finish Grading
 - 3.05 Seeding
 - 3.06 Unclassified Excavation for Utilities

- 3.07 Demolition
 - 3.08 Trenching, Backfilling and Compaction for Utilities
 - 3.09 Boring and Casing for Utility Lines
 - 3.10 Tunneling
 - 3.11 Horizontal Directional Drilling
 - 3.12 Concrete for Utilities
 - 3.13 Testing Laboratory Services
- 4.00 Sanitary Sewers
- 4.01 Sanitary Sewer System
 - 4.02 Manholes & Covers
 - 4.03 Sanitary Sewer Valves
 - 4.04 Cured-in-Place Pipe Lining
 - 4.05 Sewer Service Lateral Lining
 - 4.06 Sanitary Sewer Manhole Rehabilitation
 - 4.07 Flow Control of Sewer Lines
- 5.00 Water Lines
- 5.01 Water Lines
 - 5.02 Water Valves, Hydrants, and Appurtenances
 - 5.03 Water Service Assemblies
- 6.00 Roadway
- 6.01 Base and Subgrade Treatment
 - 6.02 Asphaltic Concrete Pavement
 - 6.03 Portland Cement Concrete Pavement
 - 6.04 Highway Signing
 - 6.05 Pavement Markings
 - 6.06 Guardrail
 - 6.07 Concrete Curbs, Gutters, Sidewalks, and Driveways
- 7.00 Storm Drainage
- 7.01 Storm Drainage
 - 7.02 Rip Rap

8.00 Electrical

8.01 Underground Electrical

9.00 Standard Details

9.01 S – 9.27 S	Sanitary Sewer
9.01 W – 9.11 W	Water
9.01 M – 9.09 M	Miscellaneous
9.01 R – 9.13 R	Roadway
9.01 D – 9.05 D	Storm Drainage

SECTION 1.00

POLICIES AND PROCEDURES

1.01 PURPOSE

- A. The purpose of this document is to assemble the Policies and Procedures that have been adopted by the Town of Chapel Hill to protect the public health, safety, and welfare, and to promote uniformity in the development of Town of Chapel Hill facilities.
- B. These standards are subject to change, and interested parties are advised to check with the City Administrator in the event there are any questions concerning the status of the published document. Updates to these standards are available at Chapel Hill's Town Hall.

1.02 DEFINITIONS

- A. Whenever the words, forms, or phrases defined or pronouns used in their stead occur in these Specifications, or any document or instrument herein contemplated or to which these specifications apply, the intent and meaning shall be construed and interpreted as follows:
- B. ABBREVIATIONS: The following organizations are referred to in these Specifications by abbreviations of their titles:
 - (a) AASHTO American Association of State Highway and Transportation Officials.
 - (b) ACI American Concrete Institute
 - (c) AFBMA Anti-Friction Bearing Manufacturer's Association
 - (d) AGA American Gas Association
 - (e) AIEE American Institute of Electrical Engineers
 - (f) AISC American Institute of Steel Construction
 - (g) AISI American Iron and Steel Institute
 - (h) ANSI American National Standards Institute
 - (i) ARAP Aquatic Resource Alteration Permit
 - (j) ASA American Standards Association
 - (k) ASTM American Society for Testing and Materials
 - (l) AWS American Welding Society
 - (m) AWWA American Water Works Association
 - (n) COE Corps of Engineers
 - (o) CSI Construction Specifications Institute
 - (p) DIP Ductile Iron Pipe
 - (q) IEEE Institute of Electrical and Electronic Engineers
 - (r) EPA U.S. Environmental Protection Agency
 - (s) HDPE High Density Polyethylene

(t)	NEC	National Electrical Code
(u)	NEMA	National Electrical Manufacturer's Association
(v)	NPDES	National Pollution Discharge Elimination System
(w)	NPT	National Pipe Thread
(x)	NSF	National Sanitation Foundation
(y)	OSHA	Occupational Safety and Health Administration
(z)	PVC	Polyvinyl Chloride
(aa)	ROW	Right-of-Way
(bb)	TDEC	Tennessee Department of Environment and Conservation
(cc)	TDOT	Tennessee Department of Transportation
(dd)	TVA	Tennessee Valley Authority
(ee)	UL	Underwriters Laboratories
(ff)	USGS	United States Geologic Survey
(gg)	WEF	Water Environment Federation

- C. AUTHORITY: Town of Chapel Hill, Tennessee.
- D. TOWN ENGINEER: The person or firm hired or contracted to be the Town Engineer.
- E. TOWN REPRESENTATIVE: An authorized representative of the Town assigned to observe the construction of the work and advise the Town of the Work's prosecution.
- F. CITY ADMINISTRATOR: City Administrator of the Town of Chapel Hill.
- G. COUNTY: The County of Fayette within the State of Tennessee.
- H. CUL-DE-SAC: A minor street with only one outlet and having an appropriate terminal for the safe and convenient reversal of traffic movement.
- I. DEDICATION: The transfer of property from private to public ownership.
- J. DESIGN ENGINEER: Engineer of record performing detail design of Plans submitted to the Town for approval of water, wastewater, roadway, drainage, electric and gas facilities.
- K. DEVELOPER: The legal or beneficial owner or owners of all the land proposed to be included in a given development or the authorized agent thereof. In addition, the holder of an option or contract to purchase, a lessee having a remaining term of not less than thirty (30) years, or other persons having an enforceable proprietary interest in such land shall be deemed to be a developer for the purpose of these Regulations.
- L. DEVELOPMENT: The act of combining raw land, roads, utilities, buildings, financing and promotion into a completed operating property with "permanent" improvements.

- M. DEVELOPMENT, SUBSTANTIAL COMPLETION OF: Completion and acceptance by the responsible agency of all streets, roads, alleys, curbs and gutters, surface drainage measures for prevention of soil erosion and private property, parks and open space and utilities (which shall be stubbed out to ownership tracts where appropriate); and certification indicating that all required improvements have been installed or that sufficient bond exists to cover all costs of completion of the improvements; and additional certificates and dedications necessary to insure adequate access for public protection and utilities as well as conformance to applicable plans and ordinance requirements.
- N. EASEMENT: A grant by the property owner of use, by the public, a corporation, or person(s) of a strip of land for specified reasons, or as created by operation of law.
- O. EMPLOYEE: Any person working on the project to which these Specification apply and who is under the direction or control of, and receives compensation from, the Town.
- P. ENGINEER: Town Engineer.
- Q. EQUIPMENT: All machinery, together with the necessary supplies for upkeep and maintenance, and also all tools and apparatus necessary for the proper construction and acceptable completion of the work.
- R. FLOODPLAIN: Those land areas in and adjacent to streams and watercourses subject to continuous or periodic inundation from 100-year flood frequency events. Floodplains shall include all areas of the County, which are designated as floodplain by the Federal Insurance Administration, by the United States Geological Survey or by the State of Tennessee. Areas designated as floodplains by the Federal Insurance Administration shall not have their base flood elevations altered without prior approval from Federal Insurance Administration.
- S. HEALTH DEPARTMENT: Shall mean the County Health Department of the appropriate jurisdiction.
- T. INSPECTOR: An authorized representative of the Engineer and/or Town assigned to make all necessary inspections and/or tests of the work performed, or of the materials furnished or being furnished by the Contractor.
- U. LABORATORY: The official testing laboratories of the Town or such other laboratories as may be designated by the Town.
- V. LOT: A tract, plot, or portion of a subdivision or other parcel of land intended as a unit for the purpose, whether immediate or future, of transfer of ownership or for building development.

- W. MATERIALS: Any substance specified for use in the work and its appurtenances.
- X. NONRESIDENTIAL SUBDIVISION: A subdivision whose intended use is other than residential, such as commercial or industrial.
- Y. OR EQUAL: Wherever a particular process, material, device, detail, or part is specified herein, followed by these words or by similar or equivalent expressions, such words or expressions shall be understood to mean and permit the use of another process, material, device, detail or part that the Engineer shall determine is fully equal in suitability, equality, durability, performance, and in all other respects, to the process, material, device, detail, or part herein specified for such use, and shall approve for such use in the work.
- Z. OWNER: The term "Owner" shall mean any person, group of persons, firm or firms, corporation or corporations, or any other legal entity having legal title to or sufficient proprietary interest in the land sought to be subdivided under these regulations.
- AA. OWNER'S ENGINEER: Shall mean the engineer or land surveyor registered and in good standing with the State Board of Registration of Tennessee who is the agent in his professional capacity of the owner of land which is proposed to be subdivided or which is in the process of being subdivided.
- BB. PLANNED RESIDENTIAL DEVELOPMENT: Shall mean the use of land and density of buildings and structures different from those which are allowed as of right within the zoning district in which the land is situated.
- CC. PLANS: The official construction drawings or exact reproduction thereof which show and describe the work to be done.
- DD. PRIMARY CIRCUITS: Shall mean wiring methods from a distribution network to a secondary supply transformer.
- EE. PROBATE JUDGE: Shall mean the County Judge of Probate for the appropriate competent jurisdiction.
- FF. PROVIDE: Shall mean furnish, install and connect, and put in good working order.
- GG. REGISTERED ENGINEER: An engineer properly licensed and registered in the State of Tennessee.
- HH. RESUBDIVISION: A change in a map of an approved or recorded subdivision plat if such change affects any street layout on such map or area reserved thereon for public use, or any lot line; or if it affects any map or plan legally recorded prior to the adoption or any regulations controlling subdivisions.

- II. SANITARY SEWER: A sewer which carries wastewater.
- JJ. SECONDARY CIRCUITS: Shall mean wiring methods from a secondary supply transformer to a meter base.
- KK. SKETCH PLAT: A sketch preparatory to the preparation of the preliminary plat (or Final Plat in the case of minor subdivision) to enable the applicant to save time and expense in reaching general agreement with the Town as to the form of the plat and the objectives of these regulations.
- LL. CHAPEL HILL WATER AND SEWER Hereafter referred to as TOWN.
- MM. SPECIAL CONDITIONS: Additions and revisions to the standard Specifications applicable to an individual project. The special conditions are intended to supplement, modify, or delete items covered in the standard Specifications. Special conditions shall prevail over General Conditions.
- NN. SPECIFICATIONS: A part of the documents containing the written directions, provisions, and requirements for completing the work. Standards for specifying material or testing which are cited in the contract Specifications by reference shall have the same force and effect as if included in the contract physically.
- OO. STATE: The State of Tennessee.
- PP. STATION: A specific point on the centerline of a sewer or water main or on the survey baseline designating some specific distance from the point of origin. Stations are numbered in terms of one hundred linear feet measured horizontally.
- QQ. STORM SEWER: A sewer which carries surface runoff and subsurface waters.
- RR. STRUCTURES: Facilities such as bridges, culverts, catch basins, inlets, retaining walls, cribbing, storm and sanitary sewer lines, water lines, underdrains, electrical ducts, manholes, handholes, lighting fixtures and poles, transformers, flexible and rigid pavements, buildings, vaults, and other manmade features that may be encountered in the work and not otherwise classified herein.
- SS. SUBDIVIDER: Any person who (1) having an interest in land, causes it, directly or indirectly, to be divided into a subdivision or who (2), directly or indirectly, sells, leases, or develops, or offers to sell, lease, or develop, or advertises for sale, lease, or development, any interest, lot, parcel, site, unit, or plat in a subdivision, and who (3) is directly or indirectly controlled by, or under direct, or indirect common control with any of the foregoing.
- TT. SUBDIVISION: Shall mean the division of a lot, tract, or parcel of land into two (2) or more lots, plats, sites, or other division of land for the purpose, whether immediate or future, of sale or of building development. It includes re-subdivision and, when

appropriate to the context, relates to the process of subdividing or to the land or territory being subdivided. It shall include all divisions of land involving the dedication of a new street or a change in existing streets.

- UU. **WIRING:** Shall mean wire and a cable, installed in raceway with all required boxes, fittings, connectors, etc. completely installed.
- VV. **WORK:** The furnishing of all labor, materials, tools, equipment and incidental necessary or convenient to the Contractor's performance of all duties and obligations imposed by the contract, Plans and Specifications.
- WW. **WRITTEN NOTICE:** Any notice to any party of the contract relative to any part of the contract in writing and considered delivered and the service thereof completed, when posted by certified or registered mail to the said party at his last given address, or delivered in person to said party or his authorized representative on the work.

1.03 STANDARD REFERENCE SPECIFICATIONS

- A. All standard Specifications referenced throughout these Specifications are to be taken as the latest version available.
- B. The following is a nonexclusive list of national standard Specifications referenced in these Specifications:

AASHTO: A Policy on Geometric Design of Highways and Streets

ANSI

- A21.10 Standard for Gray-Iron Ductile-Iron Fittings, 2-inch Through 48-inch for Water and other Liquids
- A21.11 Standard for Rubber Gasket Joints for Cast-Iron and Ductile-Iron Pressure pipe and Fittings
- A21.15 Standard for Flanged Cast-Iron and Ductile-Iron Pipe with Threaded Flanges
- A21.40 Standard for Cement-Mortar Lining for Cast-Iron and Ductile-Iron Pipe and Fittings for Water
- A21.50 Standard for Thickness Design of Ductile-Iron Pipe
- A21.51 Standard for Ductile-Iron Pipe, Centrifugally Cast in Metal Molds or Sand-Lined for Water or Other Liquids

ASTM

- A27 Mild to Medium Strength Carbon Steel Castings for General Application
- A44 Gray Iron Castings
- A53 Pipe, Steel, Black and Hot Dipped, Zinc Coated Welded and Seamless
- A82 Cold-Drawn Steel Wire for Concrete Reinforcement

A123	Zinc (Hot-Galvanized) Coatings on Products Fabricated from Rolled, Pressed, and Forged Steel Shapes, Plates, Bars, and Strip
A153	Zinc Coating (Hot-Dip) on Iron and Steel Hardware
A167	Stainless and Heat-Resisting Chromium-Nickel Steel Plate, Sheet and Strip
A184	Fabricated Deformed Steel Bars Mats for Concrete Reinforcement
A185	Welded Steel Wire Fabric for Concrete Reinforcement
A227	Steel Wire, Hard-Drawn for Mechanical Springs
A283	Low and Intermediate Tensile Strength Carbon Steel Plates, Shapes, and Bars
A307	Carbon Steel Externally Threaded Standard Fasteners
A449	Quenched and Tempered Steel Bolts and Studs
A496	Deformed Steel Wire for Concrete Reinforcement
A497	Welded Deformed Steel Wire Fabric for Concrete Reinforcement
A563	Carbon and Alloy Steel Nuts
A570	Hot-Rolled Carbon Steel Sheet and Strip, Structural Quality
A615	Deformed and Plain Billet-Steel Bars for Concrete Reinforcement
A616	Rail-Steel Deformed and Plain Bars for Concrete Reinforcement
A617	Axle-Steel Deformed and Plain Bars for Concrete Reinforcement
A648	Steel Wire, Hard Drawn for Prestressing Concrete Pipe, Spec
A746	Ductile Iron Gravity Sewer Pipe
B47	Copper trolley Wire
B108	Aluminum-Alloy Permanent Mold Castings
B209	Aluminum-Alloy Sheet and Plate
B211	Aluminum-Alloy Bar, Rod, and Wire
B221	Aluminum-Alloy Extruded Bars, Rods, Wire, Shapes and Tubes
B241	Aluminum-Alloy Seamless Pipe and Seamless Extruded Tube
B308	Aluminum-Alloy Standard Structural Shapes, Rolled or Extruded
C31	Making and Curing Concrete Test Specimens in the Field
C32	Sewer and Manhole Brick (Made from Clay or Shale)
C33	Concrete Aggregates
C39	Comprehensive Strength of Cylindrical Concrete Specimens,
C42	Obtaining and Testing Drilled Cores and Sawed Beams of Concrete
C62	Building Brick (Solid Masonry Units Made From Clay or Shale)
C76	Reinforced Concrete, Culvert, Storm Drain and Sewer Pipe
C90	Hollow Load-Bearing Concrete Masonry Units
C94	Ready Mix Concrete
C109	Compressive Strengths of Hydraulic Cement Mortars (Using 2 in. or 5MM Cube Specimens), Test Method for Portland Cement
C150	Portland Cement
C171	Sheet Materials for Curing Concrete
C172	Sampling Free Concrete
C173	Air Content of Freshly Mixed Concrete By the Volumetric Method
C216	Facing Brick (Solid Masonry Units Made from Clay or Shale)
C260	Air-Entraining Admixtures for Concrete
C309	Liquid Membrane-Forming Compounds for Curing Concrete

- C425 Compression Joints for Vitrified Clay Pipe and Fittings
- C443 Joints for Circular Concrete Sewer and Culvert Pipe, Using Rubber Gaskets
- C478 Precast Reinforced Concrete Manhole Sections
- C494 Chemical Admixtures for Concrete
- C497 Determining Physical Properties of Concrete Pipe (D-Load Test)
- C564 Rubber Gaskets for Cast Iron Soil Pipe and Fittings
- C828 Low-Pressure Air Test of Vitrified Clay Pipe Lines (4 to 12 in.)
- D698 Moisture-Density Relations of Soils and Soil-Aggregate Mixtures, Using 5.5 lb. Rammer and 12-inch. Drop
- D968 Abrasion Resistance of Organic Coatings by the Falling Abrasive Tester
- D1238 Flow Rates of Thermoplastics by Extrusion Plastometer
- D1248 Polyethylene Plastics Molding and Extrusion Materials
- D1505 Density of Plastics by the Density-Gradient Technique
- D1693 Environmental Stress-Cracking of Ethylene Plastics
- D2122 Dimensions of Thermoplastic Pipe and Fittings
- D2657 Heat Joining of Polyolefin Pipe and Fittings
- D2751 Acrylonitrile-Butadiene-Styrene (ABS) Sewer Pipe and Fittings,
- D2794 Resistance of Organic Coatings to the Effects of Rapid Deformation (Impact)
- D2837 Hydrostatic Design Basis for Thermoplastic Pipe Materials

AWWA

- C105 Polyethylene Encasement for Gray and Ductile Cast Iron Piping for Water and Other Liquids
- C115 Standard for Flanged Cast-Iron and Ductile-Iron Pipe with Threaded Flanges
- C301 Standard for Prestressed Concrete Pressure Pipe, Steel Cylinder Type, for Water and other Liquids
- C302 Standard for Reinforced Concrete Pressure Pipe, Non-Cylinder Type, for Water and Other Liquids
- C500 Standard for Gate Valves 3 in. Through 48 in. NPS for Water and Sewage Systems.
- C502 Dry-Barrel Fire Hydrants
- C504 Rubber-Seated Butterfly Valves
- C509 Resilient-Seated Gate Valves, 3 in. through 12 in. NPS, for Water and Sewer Systems
- C550 Protective Interior Coatings for Valves and Hydrants
- C600 Installation of Ductile-Iron Water Mains and their Appurtenances.
- C601 Disinfecting Water Mains

- C. The following is a list of other publications referenced in the Specifications:
1. Tennessee Department of Transportation
 - a) Manual on Uniform Traffic Control Devices for Streets, and Highways.
 - b) Standard Specifications for Highway Construction
 2. Occupational Safety and Health Administration Publications.
 - a) Safety and Health Regulations for Construction.
 3. Americans with Disabilities Act Guidelines.
 4. Architectural Barriers Act.

1.04 STANDARDS FOR CONSTRUCTION PLANS

- A. All Construction Plans must have a Title Sheet with certain required signatures, including a Tennessee Professional Engineer’s seal. The format for these signatures is illustrated below.

CONSTRUCTION PLAN CERTIFICATES

CERTIFICATE OF ACCURACY OF ENGINEERING AND DESIGN

I, (printed name of signer), do hereby certify that I am a registered Professional Civil Engineer and hereby certify that the plans, engineering and designs governing the construction of this subdivision are true and correct, and conform to the requirements set forth in the Subdivision Regulations and Technical Specification of the Town of Chapel Hill.

In witness where of, I, (printed name of signer), the said Professional Civil Engineer, hereunto set out my hand and affix my seal this _____ day of _____, 20__.

 Professional Civil Engineer
 State of Tennessee
 Certificate No. _____ (SEAL) _____

(CON’T NEXT PAGE)

CERTIFICATE OF ADEQUACY OF STORM DRAINAGE

I, (printed name of signer), do hereby certify that I am a registered Professional Civil Engineer, and that I have designed all storm water drainage for the (name of subdivision) Subdivision to assure that neither said subdivision nor any adjoining properties will be damaged or the character of land use affected by the velocity and volume of water entering or leaving same.

In witness where of, I, (printed name of signer), the said Professional Civil Engineer, hereunto set out my hand and affix my seal this _____ day of _____, 20__.

Professional Civil Engineer

State of Tennessee

Certificate No. _____

(SEAL) _____

PLANNING COMMISSIONS CERTIFICATE OF APPROVAL OF THE CONSTRUCTION PLAN

I, (printed name of signer), do hereby certify that the Town of Chapel Hill’s Planning Commission has approved this as the Construction Plan. The signing of this certificate in no way indicates approval of or acceptance of the Final Plat.

_____, 20__

Date
Planning

Secretary, Town of Chapel Hill

Commission

B. The signatures of The Town of Chapel Hill personnel indicate the following:

Review of Construction Plans for conformance with the Standard Construction Specification, a review of the Construction Plans for acceptable hydraulic, flow-carrying capacity and compatibility with long-term growth plans of the proposed water and sewer facilities.

C. The Title Sheet must contain a location map at a scale not smaller than 1”=1,000’, the name of the project, and the name(s), addresses, and telephone numbers of the Developer(s). The Title sheet must also contain an index to all sheets, and the following statement in the lower right-hand corner:

“Construction Specifications, latest edition as adopted by the Town of Chapel Hill is, hereby made a part of these Plans.”

- D. Street Plan containing the following:
1. Location of all proposed and existing streets or rights-of-way in or adjacent to the subdivision.
 2. Width of existing and proposed rights-of-way
 3. Street names
 4. Plan of all streets, showing natural and finished grades drawn to a scale of not less than 1"=100'
 5. Location of all required sidewalks and crosswalks.
- E. Storm Drainage Plan containing the following information:
1. Location of proposed drainageways, streams, and ponds in the subdivision.
 2. Topography at contour intervals not exceeding 2-foot.
 3. Location of easements and right-of-way for drainage ways and maintenance access thereof.
 4. Erosion/Sedimentation Control Plan: Grading plan with existing and finished contours extending 50' beyond the property line.
- F. Sanitary Sewer Construction Plans shall contain the following information:
1. Plan and profile of proposed sewer system, drawn at 1"=50' horizontal and 1"=10' vertical scales, with grades (%) indicated and invert elevations shown at every manhole.
 2. All pertinent planimetric features.
 3. Planimetric location of proposed sewers as related to existing or proposed: streets, alleys, highways, buildings, structures, other utilities, easements and right-of-ways.
 4. Location, size and material of all existing and proposed sewers, with locations of connections to other sewers and locations of service laterals.
 5. Direction of flow in each sewer line.
 6. Horizontal location of all manholes and other system features, and deflection angles at manholes.
 7. Construction details of typical manholes, connections, service laterals, pipe bedding, trenches, road crossings (including encasement if required), stream or ditch crossings, and slope protection.
 8. North arrow on each Plan sheet.
 9. Tennessee Professional Engineer's seal on each Plan sheet.
 10. Bench Mark elevation based on USGS datum.
 11. All topographic features, both existing and proposed.
 12. All property lines including subdivision block and lot numbers, right-of-way, and required or utilized easements.
 13. Off-site related right-of-way, as required
 14. Indications of any modifications or revisions from previous drawings.
 15. References to applicable Standard Construction Specifications of the Town with respect to the required for the construction of utility improvements proposed.

- G. Water Distribution Construction Plans shall contain the following information:
1. Plan of proposed water system, drawn at 1"=50', with all critical elevations.
 2. Location, size, and material of all existing and proposed water mains in the subdivision, (or outside the subdivision if off-site connections are required), with locations of connections to other mains, service connections, valves, fire hydrants, and all other appurtenances indicated.
 3. Construction details of typical pipe bedding, trenches, road crossings (including encasement if required), stream or ditch crossings, slope protection, service connections, fire hydrants, and valves and other related appurtenances.
 4. North arrow on each Plan sheet.
 5. Tennessee Professional Engineer's seal on each Plan sheet.
 6. All topographic features, both existing and proposed.
 7. All Property lines including subdivision block and lot numbers, right-of-way, and required or utilized easements.
 8. Off-site related right-of-way, as required.
 9. Indications of any modifications or revisions from previous drawings.
 10. References to applicable Standard Construction Specifications of the Town with respect to the required for the construction of utility improvements proposed.
- H. For all subdivision subtending land which falls within 200 ft. of any gas transmission pipeline or fiberoptic trunk line, the developer shall send a certified letter to the appropriate utility owner (with a copy to the Town) notifying them of the project. It shall be the responsibility of the applicant to provide the Town with the letter of approval and with construction drawings (to accompany the preliminary plat), accompanied by the appropriate endorsements of the referenced departments or agencies, prior to the Town's approval of the preliminary plat.
- I. The Town of Chapel Hill requires independent resident project observation on an as needed basis up to and including full-time, on-site observation, for any infrastructure related construction. The costs associated with the resident project observation will be the responsibility of the developer and shall be paid in advance to the Town of Chapel Hill prior to the developer receiving Planning Commission or City Council approval of the submitted subdivision plans. A preliminary opinion of probable costs associated with resident project observation will be presented to the developer prior to final approval of the developer's subdivision plans. The funds will be escrowed in a non-interest bearing account and neither the Town nor the developer will be eligible to collect interest from the escrowed funds. Any costs in excess of the preliminary opinion of probable costs will be billed to the developer and must be paid prior to issuance of any building permits. Any amount unused for resident project observation will be returned to the developer following final acceptance by the Town of Chapel Hill of the infrastructure and receipt of a release of liens from the infrastructure contractor and/or developer.

1.05 DESIGN CRITERIA

A. Sanitary Sewers

1. All sanitary sewers shall be designed in accordance with these criteria, specification contained in other section, and the standards of the Tennessee Department of Environment and Conservation (TDEC).
2. Sanitary sewers to be dedicated to the Town shall be constructed within dedicated rights-of-way or utility and drainage easements.
3. Sewers shall be designed for a minimum velocity of 2.0 ft./second at design flow, a maximum velocity of 5.0 ft./second, and shall accommodate design flow at one-half full. Sewer shall be a minimum 8 inch diameter and minimum slope for 8 inch sewers shall be 0.40% (0.40ft./100 ft.).
4. Design flow shall be based on a contribution of 100 gallon/capacity/day multiplied by a peak factor of 4.0. If the sewer serves other than residential developments, the design flow shall be calculated independently for each user based on their specific demand.
5. In general, sewers should be sufficiently deep to receive wastewater from basements and to prevent freezing. Insulation shall be provided for sewers that cannot be placed at a depth sufficient to prevent freezing.
6. Buoyancy of sewers shall be considered and flotation of the pipe shall be prevented with appropriate construction where high groundwater conditions are anticipated.
7. All sewers shall be designed and constructed to give mean velocities, when flowing full, of not less than 2.0 feet per second (0.6 m/s), based on Manning's formula using an "n" value of 0.013. The following are the recommended minimum slopes which should be provided; however, slopes greater than these are desirable.

<u>Nominal Sewer Size</u>	<u>Minimum Slope in Feet per 100 Feet (m/100m)</u>
8 inch (200 mm)	0.40
10 inch (250 mm)	0.28
12 inch (300 mm)	0.22
14 inch (350 mm)	0.17
15 inch (375 mm)	0.15
16 inch (400 mm)	0.14
18 inch (450 mm)	0.12
21 inch (525 mm)	0.10
24 inch (600 mm)	0.08

8. Sewers shall be laid with uniform slope between manholes.
9. All manholes shall be designed in accordance with the following guidelines:
 - a) Maximum distance between manholes shall be 400 ft.
 - b) Maximum deflection angle at manholes shall be 90 degrees.
 - c) For in/out invert elevations greater than 2.0 ft., a drop manhole shall be used. Drop manholes shall be avoided where practical..

- d) Watertight frames and covers shall be required where the proposed manholes are subject to inundation.
 - e) A vent assembly shall be required on trunk sewers at approximately 1500 ft. intervals, and at the end manhole where practical.
10. All sanitary sewers shall be constructed of the following types of pipe:
- a) Sanitary sewers 21 inches in diameter and smaller shall be constructed of ductile iron sewer pipe or PVC sewer pipe unless specific needs demand otherwise, and only then pending the review and approval of the Engineer. PVC sewer pipe shall be allowed where the pipe slope is less than or equal to 12.00% and the cut is less than or equal to 14 ft. If the slope is greater than 12.00% or the cut is greater than 14 ft., ductile iron sewer pipe shall be used. "Cut" is defined as the vertical distance from the finished ground, or surface, to the invert of the pipe.
 - b) Sanitary sewers with slopes in excess of 18% shall be constructed with concrete restraining collars designed at intervals to insure pipe stabilization.
 - c) Sanitary sewers 21 inches in diameter and larger shall be constructed of epoxy lined ductile iron sewer pipe or reinforced concrete sewer pipe with steel end ring joints, unless specific needs demand otherwise, and only then pending the review and approval of the Engineer.
 - d) Sanitary sewers crossing storm drains, creeks, or ditches shall be ductile iron pipe and will be provided with concrete encasement.
 - e) Sanitary sewers with less than 4ft. of cover shall be ductile iron pipe.
 - f) If areas which have been filled and the proposed sewer will be within the fill, ductile iron pipe must be specified. If the pipe trench through the filled area is to be undercut to natural ground and refilled to pipe grade with properly compacted crushed stone, PVC or concrete pipe may be approved by the Town.
11. All sanitary sewers shall have a minimum of 30 inches of cover in non-traffic areas and 48 inches in paved areas subject to vehicular traffic.
12. Separation between sanitary sewers and water mains shall be 10 ft. horizontal, and 18 inches vertical between the bottom of the water main and the top of the sanitary sewer.
13. Permanent easements for sanitary sewers shall be a minimum width of 20 feet. Permanent easements for sanitary sewers in excess of 14 ft. in depth shall be a minimum width of 30 feet.
14. Sewers shall be designed to serve every lot or parcel adjacent to the sewer, and manufactured, 90-degree "tees" shall be used for connection service lines to the collector sewer.
15. In general, sewers 24 inches (600 mm) or less shall be laid with straight alignment between manholes. Straight alignment shall be checked by either using a laser beam or lamping.
16. When a smaller sewer joins a large one, the invert of the larger sewer should be lowered sufficiently to maintain the same energy gradient. An

approximate method for securing these results is to place the 0.8 depth point of both sewers at the same elevation. Sewer extensions should be designed for projected flows even when the diameter of the receiving sewer is less than the diameter of the proposed extension at a manhole constructed with special consideration of an appropriate flow channel to minimize turbulence when there is a change in sewer size. The Town may require a schedule for construction of future downstream sewer relief.

17. All sanitary sewers or force main systems which discharge into the Town's system shall be designed according to these criteria.

B. Water Mains

1. All water mains shall be designed in accordance with these criteria, Specifications contained in other Sections, and the standards of the Tennessee Department of Environment and Conservation (TDEC).
2. Water mains to be dedicated to the Town shall be constructed within dedicated rights-of-way, or utility and drainage easements, at least 20 ft. in width.
3. All potential customers shall be provided a minimum of 20 psi residual pressure, at the design domestic flow:
$$Q=20 (c)^{1/2}$$

Q = flow in gpm
C = total customers served, based on 2.5 persons/customer.
4. All development shall be provided a minimum of 500 gpm fire flow unless the development requires a higher fire flow rate.
5. Maximum designed velocity shall be 5.0 ft./sec.
6. All water mains less than 12" in diameter shall be PVC Class 200, unless otherwise necessary for compliance with guidelines for pressure ratings. All water mains 12" and greater in diameter shall be ductile iron pipe, Pressure Class 350, unless otherwise necessary for compliance with guidelines for pressure ratings. All water mains shall be a minimum of 8" diameter, with the exception of water lines installed in cul-de-sacs in which the total length of pipe is less than 200 feet, which shall be 6" in diameter.
7. Water mains shall be designed for installation behind curbs where practical. Dead-end mains shall extend to the last lot or parcel being served so that no service lines are installed in front of adjacent lots or parcels. Service meters shall be located adjacent to property lines, and grouped in pairs where practical.
8. All mains shall have a minimum of 30 inches of cover in non-traffic area, and a minimum of 36 inches of cover in paved areas subject to vehicular traffic.
9. Water mains shall have 10 ft. horizontal and 18" vertical clearance from sanitary sewers, and shall have 3 ft. horizontal and 12" vertical clearance from other underground structures.
10. All service lines which cross under streets, highways, or any other paved roads must be placed inside Schedule 40 PVC casing pipe, 2" minimum size, to 2 ft. behind the curb. Size of casing will vary, depending on size of the

service line. All service lines greater than 50' in length shall be 1" diameter, minimum.

11. A 3-way valve arrangement shall be required at every water main intersection, where feasible. For connection to live mains, check with the Town for details on allowable connection features.
12. Adequate thrust blocking shall be designed for the expected pressures, including the required test pressure, 200 psi minimum.
13. Fire hydrants shall be required at a maximum spacing of 500 ft., and at no more than 300 feet from any structure. Fire hydrants shall not be permitted on lines smaller than 6" diameter.
14. A fire hydrant, or flushing hydrant or blow-off assembly, shall be required at the dead end of any water main to allow for flushing the main at 2.5 ft./sec., minimum.
15. Pressure regulators for individual services are not required by the Town except in areas of pressure exceeding 75 psi.; however, they are recommended. They are not part of the Town's system for operation and maintenance.
16. All water mains and appurtenances which connect to the Town's system shall be designed according to these criteria.

C. Roadways

1. Street Classifications

- a) Major Arterial – Primary function is to accommodate regional through traffic. Major arterials emphasize mobility over land access. These facilities have relatively long trip lengths at moderate to high operating speeds with the highest traffic volumes.
- b) Minor Arterial – Primary function is to accommodate local/regional through traffic, to connect communities, and to provide access from regional roads to lower standard roads. These facilities generally interconnect with and augment major arterial routes at moderate operating speeds with less stringent access limitations.
- c) Major Collector – Primary function is to accommodate local traffic and to provide access to local streets and adjacent properties. These facilities collect and distribute moderate amounts of traffic between arterial streets and local roads at moderate to low operating speeds. Some major collectors have sufficient traffic volumes to support signalized intersections.
- d) Minor/Neighborhood Collector – Primary function is to accommodate local traffic and to provide access to local streets and adjacent properties. These facilities collect and distribute moderate amounts of traffic between arterials, major collectors and local/ residential streets at relatively low operating speeds. These facilities provide easy movement within neighborhoods and channel neighborhood trips onto the arterial street system.
- e) Local/Residential Street – Primary function is to provide direct access to adjacent properties and connections to the higher order classified

roadways within residential neighborhoods. These facilities have low traffic volumes, low operating speeds and short trip lengths.

2. Design Policy

- a) All roadway, traffic control and signalization plans submitted to the Town of Chapel Hill shall be sealed by a professional engineer registered to practice in the State of Tennessee.
- b) The project shall be designed in accordance with criteria set forth in the latest revision of the American Association of State Highway and Transportation Officials (AASHTO) publication "A Policy on Geometric Design of Highways and Streets", the latest revision of the Federal Highway Administration (FHWA) publication "Manual on Uniform Traffic Control Devices (MUTCD)" and criteria identified within this document and/or Tennessee Department of Transportation.

3. Design Speed

a) Local/Residential

Design ADT (veh/day)	Design Speed (MPH)
<50	20
50-400	30
>400	40

b) Collector

Design ADT (veh/day)	Design Speed (MPH)
<400	30
400-2,000	40
>2,000	50

c) Arterial

Design ADT (veh/day)	Design Speed (MPH)
<2,000	40
2,000-4,000	50
>4,000	60

4. Sight Distance

- a) Sight distance along streets and at intersections shall not be less than the minimum horizontal and vertical distances as specified in the current edition of "A Policy on Geometric Design of Highways and Streets", AASHTO, for the class of street under consideration.

5. Horizontal and Vertical Geometry

- a) All horizontal and vertical design shall be in accordance with the current edition of "A Policy on Geometric Design of Highways and Streets", AASHTO.

- b) The maximum grades (%) shall not exceed the following:

Local/Residential	11%
Collector	9%
Arterial	6%

NOTE: The maximum grade for local/residential may be increased if necessary to lessen environmental impacts, provided all other design criteria are satisfied. This increase must be approved by the Town of Chapel Hill.

- c) In setting the alignment and grades for streets, due consideration shall be given to storm drainage. In general, the depth of flow in gutters and the allowable spread of water shall be consistent with the functional classification of the street. Arterial streets shall be designed to remain virtually free of water. Deeper flows and wider spreads may be tolerated on collector and land access streets. Street alignment and grades shall be designed so that, during severe rainfall events, the collector and land access streets can serve as open channels supplementary to the minor, normally piped, storm drainage system without flooding adjoining lots or building sites; therefore, mid-block sags in street grades are to be avoided and grades are to be set so as to generally parallel storm sewer gradients. During frequent normal rainfall events, appreciable runoff shall not be permitted to flow across intersections. The rate of flow for runoff contained on streets shall not normally exceed ten (10) feet per second.
 - d) Minimum grades on all roads shall be one-half of a percent (1.0%).
 - e) In general, the residential/neighborhood streets shall not have any superelevation.
 - f) The normal crown or cross-slope of all streets shall be 0.02 ft/ft.
6. Minimum Roadway Widths and Right-of-Way

Types of Street	Minimum Pavement Width	Minimum Right-of-Way
Local/Residential	23'	50'
Collector	24'	60'
Arterial	24'	60'

- 7. Median
 - a) The minimum width of a median shall be 14 feet.
- 8. Cul-de-Sac or Turnarounds
 - a) Cul-de-sac and turnaround shall be designed to accommodate emergency and service vehicles.
 - b) Cul-de-sac or turnaround may not be required for streets shorter than 200', where emergency and service vehicles are able to back out.
 - c) The maximum length of streets leading to a cul-de-sac or turnaround shall be 1000'.
 - d) Minimum radii for residential classifications shall be 30' and industrial classifications shall be 50'.

9. Intersections
 - a) Intersecting streets should meet at a ninety (90) degree angle. Where this is restrictive, due to obstacles, the intersecting streets may have a centerline angle of not less than seventy-five (75) degrees.
 - b) Intersection sight distance shall not be less than the distances specified or calculated according to the current edition of "A Policy on Geometric Design of Highways and Streets", AASHTO.
 - c) Offset T-Intersections: The centerline to centerline distance between offset T-type intersections shall be at least 150' along local streets and at least 300' along all other classified roadways.
 - d) All distances listed are minimum distances only. The actual required distance shall be determined by traffic analysis of the intersection locations and traffic volumes at each intersection.
10. Curbs, Gutters, Sidewalks, and Ramp
 - a) All curbs, gutters, sidewalks and ramps shall be designed in accordance with "A Policy on Geometric Design of Highways and Streets", AASHTO, "American with Disabilities Act Accessibility Guidelines", ADAAG, and "Architectural Barriers Act", ABA.
 - b) Sidewalks shall be a minimum of four (4) feet wide.
11. Guardrail
 - a) Guardrail shall be provided where warranted based on the current edition of "Roadside Design Guide", AASHTO.
12. Traffic Control Devices
 - a) All traffic control devices shall conform to the "Manual on Uniform Traffic Control Devices."
13. Pavement Design
 - a) Pavement design shall be completed based on the design traffic volumes (ADT) for a specific facility.
 - b) For subgrade or base, a geotech engineer shall evaluate the necessity of a subgrade treatment and determine the appropriate method as identified in TDOT Standard Specifications. Any use of these alternative methods must meet TDOT Standards.
 - c) Typical paving sections are shown on the standard drawings contained in this document.
- D. Drainage
 1. All storm drainage shall be designed in accordance with these criteria, specifications contained in other sections, and detailed in the latest edition of the Tennessee Department of Transportation (TDOT) Design Division Drainage Manual.
 2. An adequate drainage system shall be provided and properly installed to provide adequate drainage of all surface water. This is applicable but is not limited to the following activities:
 - a) Altering, rerouting, deepening, widening, obstructing, or changing in any way an existing drainage system.
 - b) Development for: residential or other subdivisions; commercial, institutional, industrial, utility or other activities.

- c) Excavating, filling, grading, draining, or paving lots.
 - d) Commencing any other development which may: significantly increase or decrease the rate and/or quantity of surface water runoff; degrade the quality of water.
 - e) Other improvement, demolition, or construction activity that may create situations such as earth/mud slides, rock falls, slides, erosion/siltation, and/or the destabilization of karst terrain.
3. It is the responsibility of the developer or property owner to provide the Town with a State approved Storm Water Pollution Prevention Plan (SWPPP) prior to any construction activities.
 4. It is the responsibility of the developer or property owner to pick up or acceptably handle the stormwater runoff as it flows onto the property from the watershed above and conduct it to an adequate drainage outfall at the property line at the lower elevation. The outfall must be sufficient capacity to receive the runoff without deterioration of the downstream drainage way. All storm drainage systems shall:
 - a) Account for both onsite and offsite stormwater.
 - b) Maintain natural drainage divides.
 - c) Convey stormwater to a stream, channel, natural drainage way, or other existing facility at admissible velocities and existing location.
 - d) Ensure the design will not adversely affect adjacent or neighboring properties.
 - e) Utilize energy dispersion systems where flows will be of sufficient velocities to cause erosion or other damage.
 5. Storm sewer systems shall be designed to prevent flooding of property of all classes by storm events having a specified return period.
 6. A professional engineer registered to practice in the State of Tennessee is required to design the stormwater system. The plans shall contain, as a minimum the following items:
 - a) Total land area.
 - b) Existing and proposed topography of existing land and impervious areas shown in a maximum of two (2) foot intervals.
 - c) Elevations of all existing and proposed streets, alleys, utilities, sanitary and stormwater sewers, and existing buildings and structures.
 - d) All existing and proposed impervious areas.
 - e) Natural or artificial watercourses.
 - f) Limits of flood plains (if applicable).
 - g) Existing and proposed slopes, terraces, or retaining walls
 - h) All existing and proposed stormwater drainage structures or features.
 - i) All stormwater structures and features immediately upstream and downstream of the site.
 - j) Erosion and siltation control plans.
 - k) Drainage calculations when required.
 - l) Drainage easements when required.

7. The potential stormwater flows for the proposed development shall be determined by the Rational Method (for areas of <100 acres of development plus contributing watershed), the United States Department of Agriculture-Soil Conservation Service Technical Release 55 (TR-55) (for areas of >100 acres of development plus contributing watershed) or other acceptable method as detailed in the TDOT Design Division Drainage Manual.
8. The rainfall intensity (frequency/duration) curve to be used in calculating peak flow using the Rational Method is in Memphis, TN curve (Refer to end of this section).
9. The runoff coefficients used in the Rational Method shall be in the ranges of values show below:

VALUES OF RUNOFF COEFFICIENTS (C) FOR USE IN THE RATIONAL METHOD	RUNOFF COEFFICIENT (C)
RURAL AREAS	
Concrete or sheet asphalt pavement	0.8 – 0.9
Asphalt macadam pavement	0.6 – 0.8
Gravel roadways or shoulders	0.4 – 0.6
Bare earth	0.2 – 0.9
Steep grassed areas (2:1)	0.5 – 0.7
Turf meadows	0.1 – 0.4
Forested areas	0.1 – 0.3
Cultivated fields	0.2 – 0.4

VALUES OF RUNOFF COEFFICIENTS (C) FOR USE IN THE RATIONAL METHOD	RUNOFF COEFFICIENT (C)
URBAN AREAS	
Flat residential, with about 30% of area impervious	0.40
Flat residential, with about 60% of area impervious	0.55
Moderately steep residential, with about 50% of area impervious	0.65
Moderately steep developed area, with about 70% of area impervious	0.80
Flat commercial/industrial, with about 90% of area impervious	0.80

NOTES: For flat slopes and/or permeable soil, use the lower values. For steep slopes and/or impermeable soils, use the higher values. For areas where there is a shallow bedrock surface, use the higher values.

Sources:

Introduction to Highway Hydraulics Hydraulic Design Series Number 4. FHWA. April 1997 by James D. Schall and Everitt V. Richardson.

Design of Roadside Channels – HDS 4. FHWA. May 1965 by James K. Searcy.

10. Taken from TR-55, the 24-hour rainfall amounts for the different frequency storm events are listed below. These shall be used in the analysis and design of the stormwater systems.

<u>Frequency</u>	<u>24-hour Rainfall Amount</u>
2 year	3.9 inches
5 year	4.8 inches
10 year	5.5 inches
25 year	6.3 inches
50 year	7.0 inches
100 year	7.7 inches

11. The following table shows the design frequency storms to be used each drainage system component:

	<u>Multilane Divided</u>			
	<u>Arterial</u>	<u>Arterial</u>	<u>Collector</u>	<u>Local</u>
Inlets	50-yr.	10-yr.	10-yr.	10-yr.
Storm Sewer	50-yr.	10-yr.	10-yr.	10-yr.
Culverts	50-yr. check for 100-yr.	50-yr. check for 100-yr.	50-yr. check for 100-yr.	50-yr. check for 100-yr.
Ditches	50-yr.	10-yr.	10-yr.	10-yr.

50-year design frequency storm shall be used in roadway sag sections.

12. The roadway freeboard shall be determined by a 50-year design frequency storm with the design high water elevation at or below the bottom of the roadway subgrade.
13. Stormwater detention facilities shall be designed to detain storm runoff in excess of the predevelopment runoff. The detained runoff shall be discharged at no greater than the 10-year frequency flow rate associated with the predevelopment conditions. Overflow or bypass capability shall be designed for a 100-year frequency storm event.
14. All driveway tile, laterals and cross drains are to be a minimum of 15 inch diameter pipe. The minimum size storm sewer pipe shall be 18 inches in diameter.
15. The depth of flow in the gutter or along any curb must not exceed the depth of the curb at any intersection or along the roadway.
16. When curb capacities are exceeded at a point, inlets shall be used intercept flow. In general, the greatest allowable spread on any facility is 8 feet, including gutter width, with the exception if the curb height is exceeded then the maximum spread shall be reduced as not to a depth greater than the curb height.

17. The maximum spacing between two adjacent catch basins should not be greater than 400 feet.
18. Cross drains and other pipe located under the pavement surface of any public street, alley, or public parking lot shall be made of reinforced concrete pipe (RCP) or Contech A-2000 pipe.
19. Longitudinal stormwater lines installed in the public right-of-way may be constructed of 14 gauge (minimum) corrugated metal pipe (CMP) or smooth interior high density polyethylene pipe (HDPE) or Contech A-2000 pipe providing they are installed a minimum of two (2) feet laterally from any public street pavement surface.
20. Stormwater pipe used under private driveways may be constructed of 14-gauge corrugated metal pipe (CMP), smooth interior high density polyethylene pipe (HDPE), Contech A-2000 pipe or reinforced concrete pipe (RCP). Each type of pipe shall conform to the minimum standards set forth in the TDOT Standard Specifications.
21. An approved concrete headwall shall be installed on all exposed ends of drainage pipe installed under public streets, commercial entrances and private driveways where required by the Town of Chapel Hill.
22. Any run of pipe placed under the road or between lots with a length greater than 200 feet shall have junction boxes placed at a maximum of every 200 feet.
23. All pipe and drainage structures are to be installed to the manufacturer specification and as a minimum to the TDOT minimum design standards.
24. All manholes, castings, valves boxes, etc. which are located within the roadway, shall be finished to the elevation of the finished paving with any adjustments occurring prior to placing the final paving surface.
25. All junction and connection structures shall have an approved manhole access.
26. All storm drainage systems shall be designed to maintain a minimum velocity of flow of 3 ft/s and a maximum velocity of 15 ft/s when flowing full.
27. All storm drainage pipe shall have a minimum cover of 24 inches in roadways.
28. All storm drainage calculations shall be submitted as part of the approval process.

RAINFALL INTENSITY-DURATION-FREQUENCY CURVES
MEMPHIS, TENNESSEE

1903-1951

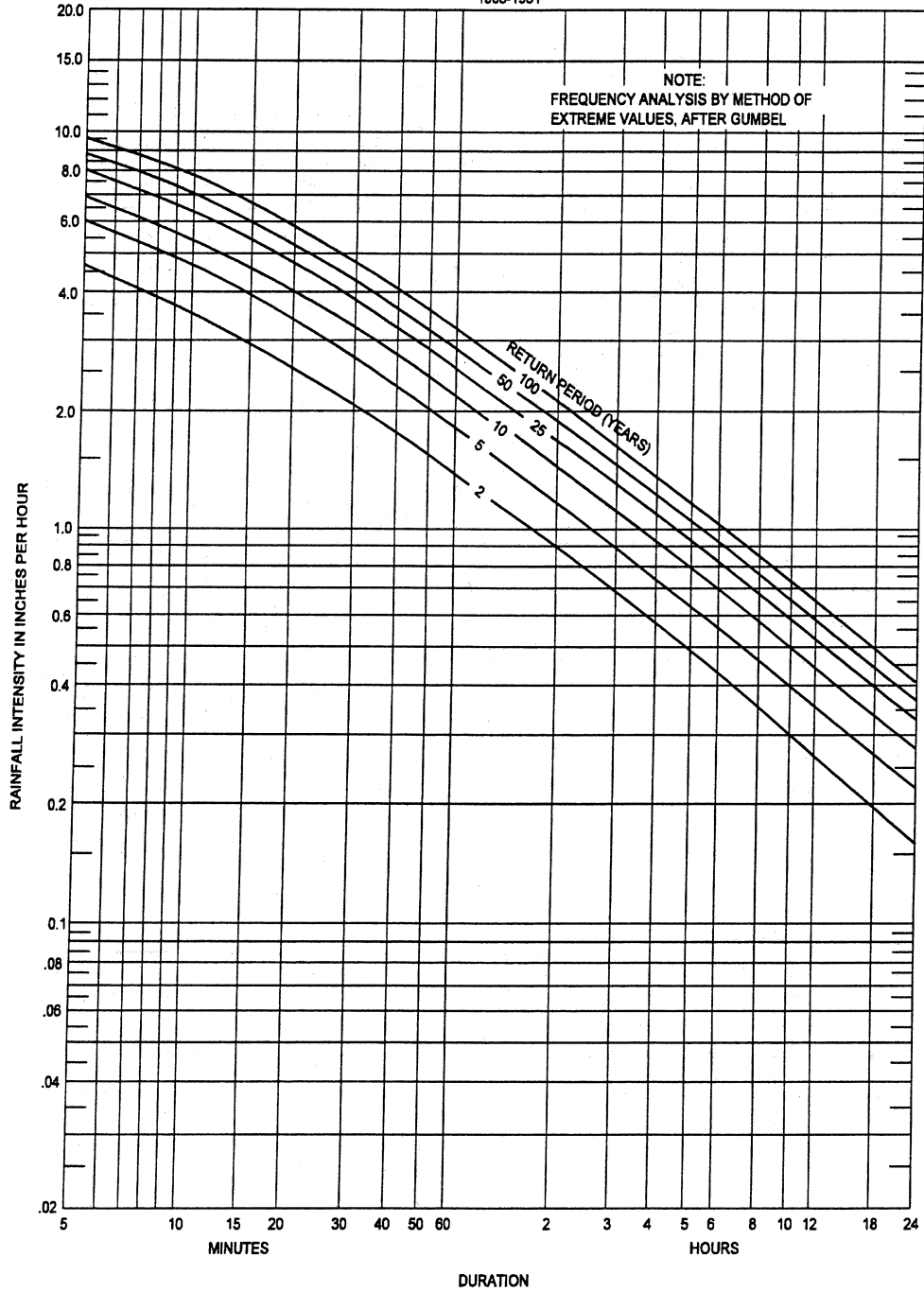

NOTE: T_c = 5 MINUTES IS A MINIMUM VALUE TO USE IN ALL CASES

E. Miscellaneous

1. All sanitary sewer, water, gas, electric and roadway facilities which connect to, or will be dedicated to, the Town's existing infrastructure shall be designed in accordance with all criteria established herein. Also, all materials, construction, and testing of such facilities shall be in accordance with all Sections of this manual, regardless of whether such facilities will be dedicated to the Town and therefor, shall be subject to inspection by the Town as it deems necessary to insure the requirements contained herein are met.
2. If a proposed street, roadway, driveway, bike path, or sidewalk crosses an existing water main or sanitary sewer line, the trench backfill for that pipeline shall meet requirements of Section 3.09. That is, the trench shall be filled completely with properly compacted select earth material or with crushed stone. The method proposed by the Design Engineer or Developer will be reviewed by the Town, and approved according to the Town's best interests.
3. Sanitary sewer lines and water mains shall be located as follows:
 - a) Trunk sewers shall be routed along natural drainage features, where practical, to provide a conduit at elevations low enough to serve the entire drainage basin within which the trunk is located, and to minimize impact on existing or proposed development.
 - b) Collector sewers shall be routed along existing or proposed street centerlines. In curved roadways, sewers shall be routed as close to center line as possible while maintaining a clearance of 5.0 feet, minimum, from faces of curbs, edges of pavement, or other drainage features.
 - c) Water mains shall be located a minimum 3.0 feet behind curbs or from the edges of pavement. Mains shall be located consistently along the same side of the street within a project or development , and street crossings shall be minimized.
 - d) Gas lines shall be located a minimum 7.0 feet behind curbs or from the edges of pavement. Lines shall be located consistently along the same side of the street within a project or development, and street crossings shall be minimized.
 - e) Electric lines shall be located a minimum of 10.0 feet behind curbs or from the edges of pavement. Lines shall be located consistently along the same side of the street within a project or development, and street crossing shall be minimized.
 - f) Deviations from the above, such as the routing of collectors' sewers along rear lot lines, shall be presented to the Town and considered on a case-by-case basis. The Town reserves the right to reject any particular layout or design of any water mains or sanitary sewers within its service areas.
4. Any facilities not specifically covered herein shall be presented to the Town for its approval. It is recommended the Town be contacted prior to detailed design to discuss specific requirements.

1.06 REVIEW AND APPROVAL

A. Preliminary Plat

1. STEP 1: The developer will consult early with Planning Staff, review the Major Road Plan, Subdivision Regulations, and Zoning Ordinance.
2. STEP 2: Fourteen days prior to the Planning Commission meeting at which the plat will be reviewed:
 - a) The developer will submit four (4) copies of a preliminary plat to the City Administrator's Office, along with applications for any requested variances from subdivision regulations.
 - b) The developer will attend the Planning Commission workshop (2nd Tuesday, 5:30 PM, Chapel Hill Town Hall) to discuss the proposal.
3. STEP 3: Town Staff will review the preliminary plat for compliance with the Chapel Hill Municipal Subdivision Regulations. A copy of these recommendations will be available at Town Hall seven days prior to the Planning Commission meeting.
4. STEP 4: The developer will attend the Planning Commission Meeting (4th Tuesday, 5:30 PM, Chapel Hill Town Hall).
 - a) The Planning Commission will approve the plat,
 - b) Approve the plat contingent upon correction; or
 - c) Deny the plat. If denied, the reasons for disapproval will be stated in writing.
5. STEP 5: The developer will make necessary corrections or repeat Step 1) through Step 4) as necessary until approved or approved with contingencies. Submit approved (or corrected) plat to the City Administrator's Office. The City Administrator will obtain the necessary signatures.

B. Construction Plans

1. STEP 1: Twenty-one days prior to the Planning Commission meeting at which the development will be discussed, the developer will submit two (2) copies of signed and stamped Construction Plans to Town Hall. Construction plans will not be accepted prior to preliminary plat approval.
2. STEP 2: Town Engineer will review the construction plans for compliance with the standards set forth in the Town of Chapel Hill Standard Utility Specifications.
3. STEP 3: The Town Engineer will return one (1) set of "mark-up" drawings and required corrections/revisions to the Design Engineer within fourteen (14) days.
4. STEP 4: The Design Engineer will make necessary corrections.
 - a) As needed, the Design Engineer will contact the Town Engineer regarding corrections/revisions, data and measurements, etc.
 - b) The Design Engineer will return "mark-up" drawings and two (2) corrected sets of plans to the City Administrator's Office.
5. STEP 5: The Town Engineer will review the Construction Plans a second time. Step 7 through Step 9 will be repeated as necessary until all corrections/revisions necessary for compliance have been made.

6. STEP 6: The Town Engineer will submit final proposed Construction Plans along with a memorandum certifying hydraulic analysis results, recommended fees or charges, and recommendation for acceptance of Construction Plans.
7. STEP 7: The City Administrator's Office will notify the Design Engineer of the following by memorandum:
 - a) Acceptance of Construction Plans
 - b) Amount of fees
8. STEP 8: The Design Engineer will provide the following to the City Administrator:
 - a) Original Title Sheet for Construction Plans, with necessary signature blocks
 - b) Payment, by check or letter of credit, for any fees or charges or a Letter of Request that submission of payment be delayed until or after other approvals, not to exceed 60 days.
9. STEP 9: The City Administrator will obtain the necessary signatures on the Construction Plans.
10. STEP 10: The Developer (or Design Engineer) will submit final Construction Plans to the Planning Commission for approval.
11. STEP 11: If approved, the Design Engineer will submit two (2) copies of the final Construction Plans to the City Administrator, who will keep one approved set and forward another to the Town Engineer.
12. STEP 12: The City Administrator will obtain the necessary signatures.

C. Final Plat

1. STEP 1: The developer will complete required improvements or provide an adequate surety instrument as detailed in the Chapel Hill Municipal Subdivision Regulations.
2. STEP 2: Fourteen days prior to the Planning Commission meeting at which the final plat will be reviewed:
 - a) The developer will submit ten (10) copies of the plat to the City Administrator's Office, along with applications for any requested variances from subdivision regulations.
 - b) The developer will attend the Planning Commission workshop (2nd Tuesday, 5:30 PM, Chapel Hill Town Hall) to discuss the proposal.
3. STEP 3: Town Staff will review the final plat for compliance with the Chapel Hill Municipal Subdivision Regulations. A copy of these recommendations will be available at Town Hall seven days prior to the Planning Commission meeting.
4. STEP 4: The developer will attend the Planning Commission Meeting (4th Tuesday, 5:30 PM, Chapel Hill Town Hall).
 - a) The Planning Commission will approve or disapprove the final plat.

- b) If disapproved, the reasons for disapproval will be stated in writing along with necessary steps for approval.

1.07 SCHEDULE

- A. After construction plan approval has been granted by the Town and before any construction activity commences, a pre-construction meeting will be held at the Town of Chapel Hill Town Hall. The participants of the meeting shall include the resident inspector, the Public Works director, the Light, Gas and Water Superintendent, the property developer, and the construction foreman.
- B. The developer will be required to submit a proposed construction schedule to the Town at the pre-construction meeting.
- C. The developer will be required to notify the Town and the resident inspector a minimum of 48 hours before beginning any construction activities.

1.08 BONDS FOR IMPROVEMENTS

- A. Performance Bond for Water, Sewer, Drainage, and/or Roadway Improvements: In lieu of completing all of the improvements in a subdivision prior to final plat approval, a developer may provide the Town with a bond whereby the developer agrees to complete the improvements pursuant to a Performance Bond for Water, Sewer, Drainage, and Roadway Improvements. The Town may accept cash, a letter of credit (good for not less than thirteen (13) months), or surety from a corporate surety licensed in the State of Tennessee, provided the security offered is deemed acceptable by the Town's attorney. The amount of the bond shall be estimated by the developer and then fixed by the Town's consulting engineer in an amount equal to at least 100% of the cost of the uncompleted improvements provided; however, when improvements have been "substantially completed" but remaining subdivision improvements are incomplete, a performance bond in an amount of not less than 15% of the total cost of the improvements must be posted. All costs to the Town incurred in connection with review associated with fixing the amount of and approving the performance bond must be reimbursed by the developer as a condition precedent to approval and acceptance of the bond. The performance bond must be posted with the submittal of the final plat.

Improvements must be completed within one (1) year of final plat approval unless this time is extended by agreement of the Town.

The responsibility for timely seeking an extension of time to complete improvements rests entirely with the developer. Failure to seek and obtain an extension (for a period not to exceed on (1) year) shall void the Town's approval. Any extension granted by the Town will be granted only upon receipt of a new bond with sufficient security.

In the event of failure by the developer to comply with conditions of the bond, the Town may declare the security for the bond forfeited and use the receipts of such security to complete the improvements. Unused portions of the security, if any, will be returned as appropriate. The Town shall not be limited to the amount of the bond if the costs of completing the developer's agreement exceeds said amount.

- B. Maintenance Bond for Improvements. At the time of dedication and completion of subdivision improvements, the developer shall apply in writing (by letter) for acceptance of the improvements into the water distribution, sanitary sewer, roadway, and drainage systems of the Town. The letter must be accompanied by the following:
1. A statement signed by the developer and its consulting engineer, including a certification that the required improvements are complete, the total construction costs of said improvements, a certification that the improvements were constructed in accordance with standard specifications of the Town and that they have successfully passed all testing required by the Town and TDEC. The statement shall also include a certification that the developer and his engineer know of no defects from any cause in the improvements, and that the improvements are free and clear from any encumbrance or lien;
 2. An agreement properly dedicating said improvements to the Town;
 3. Two (2) copies of as-built drawings of the improvement,
 4. A Water, Sewer, Roadway, Drainage, Electric and/or Gas Improvements Maintenance Bond together with sufficient security deemed acceptable by the Town's attorney.

The amount of this bond shall be fixed by the Town's consulting engineer in an amount not less than 15% of the cost of the improvements. All costs to the Town incurred in connection with review associated with fixing the amount of and approving maintenance bonds must be reimbursed to the Town as a condition precedent to acceptance of the bond and the improvements.

The Maintenance Bond shall secure the Town against defects or damage to the improvements arising out of defective or inferior materials or defective or negligent workmanship arising, occurring, or becoming apparent with one (1) year from the date of acceptance of the improvements. Inspection or acceptance of the water and sewer improvements by the Town shall in no way affect the developer's obligation under the bond.

The Town has the option of requiring that the Maintenance Bond be extended, in 1 year increments, if there is reason to believe that the infrastructure may not meet acceptable standards for operation or require unusual maintenance, as adjudged by Town's staff and Town's Consulting Engineer. However, release of bond requirements shall not be unreasonably withheld.

The application of acceptance should be filed with the City Administrator at least seven (7) days prior to the meeting of the Town at which acceptance will be requested.

END OF SECTION

SECTION 2.01

CONSTRUCTION REFERENCE STANDARDS

PART 1 – GENERAL

1.01 REQUIREMENTS INCLUDED

- A. Applicability of Reference Standards.
- B. Provision of Reference Standards at site.
- C. Acronyms used in Policy Documents for Reference Standards. Source of Reference Standards.

1.02 QUALITY ASSURANCE

- A. For products or workmanship specified by association, trades, or Federal Standards, comply with requirements of the standard, except when more rigid requirements are specified or are required by applicable codes.
- B. The date of the standard is in effect as of the date of the approved construction plans

1.03 SCHEDULE OF REFERENCES

AASHTO	American Association of State Highway and Transportation Officials 444 North Capitol Street, N.W. Washington, DC 20001
ACI	American Concrete Institute P. O. Box 19150 Reford Station Detroit, MI 48219
AGC	Associated General Contractors of America 1957 E. Street, N.W. Washington, DC 20006
AI	Asphalt Institute Asphalt Institute Building College Park, MD 20740
AITC	American Institute of Steel Construction 333 W. Hampden Avenue Englewood, CO 80110

AISC	American Institute of Timber Construction 400 North Michigan Avenue Eighth Floor Chicago, IL 60611
AISI	American Iron and Steel Institute 1000 16th Street, N.W. Washington, DC 20036
ANSI	American National Standards Institute 1430 Broadway New York, NY 10018
ASME	American Society of Mechanical Engineers 345 East 47th Street New York, NY 10017
ASPA	American Sod Producers Association Association Building Ninth and Minnesota Hastings, NE 68901
ASTM	American Society of Testing and Materials 1916 Race Street Philadelphia, PA 19103
AWWA	American Water Works Association 6666 West Quincy Avenue Denver, CO 80235
CLFMI	Chain Link Fence Manufacturers Institute 1101 Connecticut Avenue, N.W. Washington, DC 20036
CRSI	Concrete Reinforcing Steel Institute 933 Plum Grove Road Schaumburg, IL 60195
EJCDC	Engineers' Joint Contract Documents Committee American Consulting Engineers Council 1050 15th Street, N.W. Washington, DC 20005
FM	Factory Mutual System 1151 Boston-Providence Turnpike

FS	Norwood, MA 02062 Federal Specification General Services Administration Specifications and Consumer Information Distribution Section (WFSIS) Washington Navy Yard, Bldg. 197 Washington, DC 20407
MIL	Military Specification Naval Publications and Forms Center 5801 Tabor Avenue Philadelphia, PA 19120
PCA	Portland Cement Association 5420 Old Orchard Road Skokie, IL 60077
PCI	Prestressed Concrete Institute 201 North Wacker Drive Chicago, IL 60606
PS	Product Standard U. S. Department of Commerce Washington, DC 20203
SDI	Steel Deck Institute P. O. Box 3812 St. Louis, MO 63122
SJI	Steel Joist Institute 1703 Parham Road Suite 204Richmond, VA 23229
SSPC	Steel Structures Painting Council 4400 Fifth Avenue Pittsburgh, PA 15213
TAS	Technical Aid Series Construction Specifications Institute 601 North Madison Street Alexandria, VA 22314
UL	Underwriters' Laboratories, Inc. 333 Pfingston Road Northbrook, IL 60062

PART 2 – PRODUCTS

N/A

PART 3 – EXECUTION

N/A

END OF SECTION

SECTION 2.02

GENERAL PROJECT REQUIREMENTS

PART 1 – GENERAL

1.01 SECTION INCLUDES

- A. General Requirements

1.02 GENERAL REQUIREMENTS

- A. Smoking and Fire Precautions: No smoking, fire, or use of any fire or explosion producing tools or equipment shall be permitted on the premises or at any locations where such may endanger said premises or the current operations thereon.
- B. Manufacturers Qualifications: The manufacturers of all materials and equipment used must be reputable and regularly engaged in the manufacture of the particular material or equipment for the use and service to which it will be subjected.
- C. Contractor Shall Pay for All Laboratory Inspection Service: All materials and equipment used in the construction of the project shall be subject to adequate inspection and testing in accordance with accepted standards. The laboratory or inspection agency shall be selected by the Contractor and approved by the Town. Contractor to pay for all laboratory inspection services as a part of the Contract. Submit all material test reports to the Town in triplicate.
- D. Compliance With State and Local Laws: Comply with all applicable requirements of state and local laws and ordinances to the extent that such requirements do not conflict with federal laws or regulations.
- E. Protection of Public and Private Property: Take special care in working areas to protect public and private property. The contractor shall replace or repair at his own expense any damaged water pipes, power and communication lines, or other public utilities, roads, curbs, gutters, sidewalks, drain pipes, ponds or pond structures, sewer drainage ditches, all properties and fixtures (both permanent and temporary) fences, and all plantings, including grass or sod on the site of the work. Leave the site in original or better condition after all cleanup work has been done.
- F. Markers: Preserve all USGS, TVA, and State of Tennessee property markers and private markers. Do not remove or disturb any such markers without prior approval from the Owner. Any removal and replacement of such markers shall be at the expense of the Contractor.

- G. Non-discrimination: The Contractor agrees to hire qualified persons without regard to race, creed, color, sex, or national origin for the performance of the work specified in this contract.
- H. Pavement Repair and/or Replacement: Whenever pipe trenches are cut across or along existing pavement or shoulders, backfill same and restore traffic over the cuts as quickly as possible by constructing a temporary surface with twelve (12) inches of Class A, grade D crushed stone. Add material and otherwise maintain such surface until the permanent pavement is restored by the Contractor or until the entire project is accepted.
- I. Department of Transportation Permits: The Owner shall secure any permits and provide bond as required by the Tennessee Department of Transportation or Fayette County, Tennessee for the installation of permanent facilities on highway rights-of-way. All such work shall be coordinated with and be subject to the approval of the Department of Transportation.
- J. Approved Chemicals: All chemicals used during project construction or furnished for project operation, whether herbicide, pesticide, disinfectant, polymer, reactant, or of other classification, must show approval of either EPA or USDA. The use of all such chemicals and the disposal of residues shall be in strict conformance with instructions.
- K. Catalogue Data for Town: Provide duplicate complete, bound sets of a compilation of catalog data of each manufactured item of mechanical and electrical equipment used in the work, and present this compilation to the Town before final project close-out. Include descriptive data and printed installation, operating, and maintenance instruction (including a parts list for each item of equipment). Provide a complete double index as follows:
1. Listing the products alphabetically by name.
 2. Listing alphabetically the names of manufacturers whose products have been incorporated in the work, together with their addresses and the names and addresses of the local sales representative.
- L. Operation and Maintenance Instruction to Town: Where the specifications for specific equipment require that a factory service representative provide operation and maintenance instruction to the Town for that equipment, this service is to be performed by prior arrangement with the Town after and in addition to the manufacturer's instructions to the Contractor for installation and start-up. The individual performing the instruction to the Town shall be trained and/or certified by the manufacturer as its authorized operation, maintenance, and service specialist. If the said specialist is not a regular full-time employee of the manufacturer, the specialist's qualifications shall be submitted to the Town for review and approval prior to scheduling the site visit for instructions to the Town.

PART 2 – PRODUCTS

N/A

PART 3 – EXECUTION

N/A

END OF SECTION

SECTION 2.03

FIELD ENGINEERING

PART 1 – GENERAL

1.01 RESPONSIBILITIES

- A. The Contractor shall be responsible for providing and paying for any surveying or engineering services required during the construction. The Contractor must retain qualified personnel as work may require.
- B. The Town shall be responsible only for inspections of all water, sanitary sewer, roadway, and drainage facilities.
- C. The Town will not supply Contractor with any survey control points.

1.02 FIELD ENGINEERING

- A. Contractor is responsible for providing and paying for engineering and surveying services required during construction.
- B. Field engineering by the Contractor, such as structural design of form work, scaffolding, special earthwork, hydraulic groundwater control design, or other engineering work will be analyzed on a case-by-case basis, due to the specialized requirements of portions of the work.
- C. Construction staking and cut sheets shall be performed and prepared by a registered land surveyor. Cut sheets for sanitary sewers shall include:
 - 1. Beginning and ending manholes
 - 2. Distance between manholes
 - 3. Pipe materials, size and slope of line
 - 4. Centerline ground elevations and invert elevations
 - 5. Depth of cut at minimum 50' intervals

PART 2 – PRODUCTS

N/A

PART 3 – EXECUTION

N/A

END OF SECTION

SECTION 2.04

SHOP DRAWINGS, PRODUCT DATA, AND SAMPLES

PART 1 - GENERAL

1.01 REQUIREMENTS INCLUDED

- A. Submit shop drawings, product data, and samples required by the Contract Documents.

1.02 RELATED REQUIREMENTS

- A. Conditions of the Contract: Definitions and additional responsibilities of the parties.
- B. Designate in the construction schedule, or in a separate coordinated schedule, the dates for submission and the dates that reviewed Shop Drawings, Product Data and Samples will be needed.

1.03 SHOP DRAWINGS

- A. Drawings shall be presented in a clear and thorough manner.
 - 1. Details shall be identified by reference to sheet and detail, schedule or room numbers shown on the Contract Documents.
 - 2. Reproduction of Contract Drawings for Shop Drawings is not acceptable.

1.04 PRODUCT DATA

- A. Preparation
 - 1. Clearly mark each copy to identify pertinent products or models.
 - 2. Show performance characteristics and capacities.
 - 3. Show dimensions and clearances required.
 - 4. Show wiring or piping diagrams and controls.
- B. Manufacturer's standard schematic Drawings and Diagrams.
 - 1. Modify drawings and diagrams to delete information which is not applicable to the work.
 - 2. Supplement standard information to provide that specifically applicable to the work.

1.05 SAMPLES

- A. Office samples shall be of sufficient size and quantity to clearly illustrate:
 - 1. Functional characteristics of the product, with integrally related parts and attachment devices.
 - 2. Full range of color, texture and pattern.

1.06 CONTRACTOR RESPONSIBILITIES

- A. Review Shop Drawings, Product Data and Samples prior to submission.
- B. Determine and verify:
 - 1. Field measurements.
 - 2. Field construction criteria.
 - 3. Catalog numbers and similar data.
 - 4. Conformance with specifications.
- C. Coordinate each submittal with requirements of the work and of the Contract Documents.
- D. Notify the Engineer in writing, at the time of submission, of any deviations in the submittals from requirements of the Contract Documents.
- E. Begin no fabrication or work, which requires submittals until return of submittals with stamped approval.

1.07 SUBMISSION

- A. Make submittals promptly in accordance with approved schedule, and in such sequence as to cause no delay in the work or in the work of any other contractor.
- B. Number of submittals required:
 - 1. Shop Drawings: One (1) clear and legible electronic copy submitted via email to Engineer.
- C. Each Submittal shall contain:
 - 1. Cover Sheet with following information:
 - a. Prepared By: *Insert Supplier's Name*
 - b. Date: *Insert Date Submittal Prepared*
 - c. Prepared For: *Insert Contractor's Name*
 - d. Reviewed By: *Signature Of Reviewer/Contractor & Date Reviewed*
 - e. Project Title: *Insert Project Name*
 - f. Engineer: *Insert Engineer Company/Name*
 - g. Product: *Insert Name of Material/Product being submitted (for example: PVC Pipe, Gate Valve, etc.) with specification section number*
 - h. Description: *Insert Job Specific Description (for example: gate valves for water mains, pressure gauges for PRV pit, etc.)*
 - 2. Provide enough room on cover sheet for the following to be overlaid:

<input type="checkbox"/> Approved <input type="checkbox"/> Approved as corrected <input type="checkbox"/> Rejected <input type="checkbox"/> Revise and Resubmit <input type="checkbox"/> Submit Specific Item
<p>This review is only for general conformance with the design concept of the project and general compliance with the information given in the contract documents. Corrections or comments made on the shop drawings during this review do not relieve contractor from compliance with the requirements of the plans and specifications. Approval of a specific item shall not include approval of an assembly of which the item is a component. Contractor is responsible for: dimensions to be confirmed and correlated at the jobsite; information that pertains solely to the fabrication processes or to the means, methods, techniques, sequences and procedures of construction; coordination of the Work of all trades; and for performing all work in a safe and satisfactory manner.</p> <p>HETHCOAT & DAVIS, INC.</p> <p>Date _____ By _____</p>

3. Manufacturer of product clearly identified.
4. Field sizes and dimensions, clearly identified as such.
5. Applicable standards, such as ASTM or AWWA Specification numbers.
6. Identification of deviations from Contract Documents.
7. Identification of revisions on submittals.

1.08 RESUBMISSION REQUIREMENTS

- A. Make any corrections or changes in the submittals required by the Engineer and resubmit until approved.
- B. Shop Drawing and Product Data:
 1. Revise initial drawings or data and resubmit as specified for the initial submittal.
 2. Indicate any changes that have been made other than those requested by the Engineer.
- C. Samples: Submit new Samples as required for initial submittal.

1.09 DISTRIBUTION

- A. Distribute reproductions of Shop Drawings and copies of Product Data, which carry the Engineer's stamp of approval to:
 1. Job site file.
 2. Other affected contractors.
 3. Subcontractors.

4. Suppliers or fabricators.

PART 2 - PRODUCTS

N/A

PART 3 - EXECUTION

N/A

END OF SECTION

SECTION 2.05

TEMPORARY CONTROLS

PART 1 – GENERAL

1.01 REQUIREMENTS INCLUDED

- A. Provide and maintain methods, equipment and temporary construction, as necessary to provide controls over environmental conditions at the construction site and related areas under the Contractor's control; remove physical evidence of temporary facilities at completion of work.

1.02 DUST CONTROL

- A. Provide positive methods and apply dust control materials to minimize raising dust from construction operations and provide positive means to prevent air-borne dust from dispersing into the atmosphere.

1.03 WATER CONTROL

- A. Provide methods to control surface water to prevent damage to the Project, the site or adjoining properties.
 - 1. Control filling, grading and ditching to direct surface drainage away from excavations, pits, tunnels and other construction areas; and to direct drainage to proper runoff.
- B. Provide, operate and maintain hydraulic equipment of adequate capacity to control surface water.
- C. Dispose of drainage water in a manner to prevent flooding, erosion or other damage to any portion of the site or to adjoining areas, as required by local rules and regulations.

1.04 DEBRIS CONTROL

- A. Maintain all areas under Contractor's control free of extraneous debris.
- B. Initiate and maintain a specific program to prevent accumulation of debris at the construction site, storage and parking areas, or along access roads and haul routes.
 - 1. Provide containers for deposit of debris.
 - 2. Prohibit overloading of trucks to prevent spillage on access roads or haul routes.
 - 3. Provide periodic inspection of traffic areas to enforce requirements.

- C. Schedule periodic collection and disposal of debris. Provide additional collections and disposals of debris whenever the periodic schedule is inadequate to prevent accumulation.

1.05 POLLUTION CONTROL

- A. Provide methods, means and facilities required to prevent contamination of soil, water or atmosphere by the discharging of noxious substances from construction operations.
- B. Provide equipment and personnel, perform emergency measures required to contain any spillage, and to remove contaminated soils or liquids.
 - 1. Excavate and dispose of any contaminated earth off-site and replace with suitable compacted fill and topsoil.
- C. Take special measures to prevent harmful substances from entering public waters.
 - 1. Prevent disposal of waste, effluents, chemicals or other such substances adjacent to streams or in sanitary sewers.
- D. Provide system for control of atmospheric pollutants.
 - 1. Prevent toxic concentrations of chemicals.
 - 2. Prevent harmful disposal of pollutants into the atmosphere.

1.06 TRAFFIC CONTROL

- A. Contractor shall provide traffic control devices and signage as set forth by the latest edition of the Manual of Uniform Traffic Control Devices to protect the public where utility work is undertaken inside roadway areas.

PART 2 – PRODUCTS

N/A

PART 3 – EXECUTION

N/A

END OF SECTION

SECTION 2.06

TRANSPORTATION AND HANDLING

PART 1 – GENERAL

1.01 PACKING AND TRANSPORTATION

- A. Require supplier to package products in boxes or crates for protection during shipment, handling, and storage. Protect sensitive products against exposure to elements and moisture.
- B. Protect sensitive equipment and finishes against impact, abrasion, and other damage.

1.02 DELIVERY

- A. Arrange deliveries of products in accordance with construction schedules and in ample time to facilitate inspection prior to installation.
- B. Coordinate to avoid conflict with work and conditions at the site. Specifically coordinate to determine:
 - 1. Work of the Town.
 - 2. Work of other contractors.
 - 3. Availability of equipment and personnel for handling products.
 - 4. Town's use of premises.
- C. Deliver products in undamaged condition, in manufacturer's original containers or packaging, with identifying labels intact and legible.
- D. Clearly mark partial deliveries of component parts of equipment to permit easy accumulation of parts and to facilitate and legible.
- E. Immediately on delivery, inspect shipments to assure:
 - 1. Compliance with Construction Plans and approved submittals.
 - 2. Quantities are correct.
 - 3. Containers and packages are intact and that labels are legible.
 - 4. Products are properly protected and undamaged.

1.03 PRODUCT HANDLING

- A. Provide equipment and personnel to handle products by methods to prevent soiling or damage to products or packaging.
- B. Provide additional protection during handling as necessary to prevent scraping, marring, or otherwise damaging products or surrounding spaces.

- C. Handle products by using methods that will prevent bending or over stressing.
- D. Lift heavy components only at designated lifting points.

PART 2 – PRODUCTS

N/A

PART 3 – EXECUTION

N/A

END OF SECTION

SECTION 2.07

STORAGE AND PROTECTION

PART 1 – GENERAL

1.01 STORAGE, GENERAL

- A. Store products immediately on delivery in accordance with manufacturer's instructions with seals and labels intact. Protect until installed.
- B. Arrange storage in a manner to provide access for maintenance of stored items and for inspection.

1.02 EXTERIOR STORAGE

- A. Provide substantial platforms, blocking, or skids to support fabricated products above ground; slope to provide drainage. Protect products from soiling and staining.
- B. Store loose granular materials on clean, solid surfaces such as pavement, or on rigid sheet materials to prevent mixing with foreign matter.
- C. Provide surface drainage to prevent erosion and ponding of water.
- D. All pipe and valves shall be stored with the ends capped to prevent debris from entering the materials.
- E. All PVC pipe stored onsite longer than 30 days shall be covered by tarps to prevent degradation by ultraviolet light.

1.03 MAINTENANCE OF STORAGE

- A. Verify that surfaces of products exposed to the elements are not adversely affected; that any weathering of finishes is acceptable under requirements of Contract Documents.

PART 2 – PRODUCTS

N/A

PART 3 – EXECUTION

N/A

END OF SECTION

SECTION 2.08

PROJECT CLOSEOUT

PART 1 – GENERAL

1.01 SUBSTANTIAL COMPLETION

- A. When the work task is considered to be substantially complete, submit the following to the Town:
 - 1. Written notice that the specific work task is substantially complete.
 - 2. List of items remaining to be complete or corrected.
- B. Within seven (7) working days, the Town will inspect to determine status of completion and compile a punch list of items to be completed and corrected. If Town determines that Work is not substantially complete, they will immediately notify Contractor in writing. The Town will generally point out his reasons, but he will not be obligated to give an exhaustive list of discrepancies.
- C. Contractor's Duties: Remedy deficiencies and send the Town another written Notice of Substantial Completion.
- D. Town's Actions:
 - 1. Re-inspect the Work
 - 2. When the Town considers Work substantially complete, they will issue the Certificate of Substantial Completion.

1.02 TOWN OCCUPANCY

- A. Town's Action: Occupy the Project, or designated portion of the Project, in accordance with provisions of the Certificate of Substantial Completion.
- B. Contractor's Duties:
 - 1. Make corrections listed on punch list attached to Certificate of Substantial Completion.
 - 2. Perform final clean-up

1.03 FINAL COMPLETION

- A. When this project is considered to be complete, Contractor shall submit certification in indication of the following:
 - 1. Contract Documents have been reviewed and Work has been inspected for compliance with those Documents.
 - 2. Work has been completed in accordance with Contract Documents.
 - 3. All punch list items have been corrected.

4. Equipment and systems have been tested in presence of Town's Representative and are operational.
 5. Work is complete and ready for final inspection.
- B. Town's Action during Final Inspection:
1. Inspect to verify the status of completion within seven (7) working days.
 2. If he considers Work incomplete or defective, he will promptly notify Contractor in writing, listing deficiencies.
- C. Contractor's Duties: Take immediate action to correct deficiencies, and send certification to Town that Work is complete.
- D. When the Town determines that Work is acceptable, he will request Contractor to make closeout submittals.

1.04 REINSPECTION FEES

- A. Should status of completion of work require re-inspection by Town due to failure of work to comply with Contractor's claims on initial inspection, Town will deduct the amount of Town compensation for re-inspection services from final payment to Contractor.

1.05 CONTRACTOR'S CLOSEOUT SUBMITTALS REQUIRED

- A. Project Record Documents: Comply with Section 2.09.
- B. Evidence of Payment and Release of Liens: Contractor shall advertise in local paper for two (2) consecutive weeks of project closure and provide Town with evidence of same.
- C. Consent of Surety to Final Payment.
- D. Copies of all test results.
- E. Documents required by State Licensure inspectors and other authorities having jurisdiction.

PART 2 – PRODUCTS

N/A

PART 3 – EXECUTION

N/A

END OF SECTION

SECTION 2.09

PROJECT RECORD DOCUMENTS

PART 1 – GENERAL

1.01 SECTION INCLUDES

- A. The Policy Manual requires the Contractor to maintain a record copy of the following for Town's review:
 - 1. Drawings.
 - 2. Approved shop drawings, product data, and samples.
 - 3. Records of all changes made during construction.

- B. In addition to the above, the Contractor shall maintain a record copy of the following where applicable:
 - 1. Field test results.
 - 2. Manufacturer's certificates.
 - 3. Fixed equipment manuals.

1.02 RECORDING

- A. Record information concurrently with construction progress.
 - 1. Do not conceal work until required information has been recorded.

- B. Contract Drawings: Legibly mark each item to record actual construction, including the following:
 - 1. Measured horizontal and vertical locations of underground utilities, valves, etc. referenced to building exterior lines or other distinguishable permanent features such as power poles, inlets, etc. Show direction of flow of pipe and depth of piping underground.
 - 2. Field changes of dimensions and details.
 - 3. Details not on original Contract Drawings.

1.03 RECORD DRAWINGS

- A. Record Drawings which are required for Town records shall be recorded on reproducible by the Contractor.

- B. The Contractor shall transfer all changes recorded on construction drawings on the Record Drawing.
 - 1. All information shall be recorded neatly and legibly.
 - 2. Use separate colors for recording information about each major system.

1.04 SUBMITTALS

- A. At Contract Closeout, deliver Record Drawings to the Town.
- B. Submit Record Documents under cover of a transmittal letter containing:
 - 1. Date.
 - 2. Project title.
 - 3. Contractor's and subcontractor's names and addresses.
 - 4. Certification that each document submitted is complete and accurate.
 - 5. Signature of Contractor or his authorized representative.
- C. Submit the following for record drawings:
 - 1. Two (2) mark-up copies of Record Drawings.
 - 2. An electronic copy of Record Drawings in .dwg format.

PART 2 – PRODUCTS

N/A

PART 3 – EXECUTION

N/A

END OF SECTION

SECTION 2.10

CLEANING

PART 1 – GENERAL

1.01 CLEANING

- A. Maintain premises and public properties free from accumulations of waste, debris, and rubbish caused by operations.
- B. Keep streets clean from mud, dirt, debris, and other materials removed from the job site. Promptly remove mud and dirt tracked by vehicles from street surfaces.
- C. At completion of work, remove waste materials, rubbish, tools, equipment, machinery, and surplus materials. Clean all sight-exposed surfaces. Leave project clean and ready for occupancy.
- D. Conduct cleaning and disposal operations to comply with local ordinances and anti-pollution laws.
 - 1. Do not burn or bury rubbish and waste materials on project site.
 - 2. Do not dispose of volatile waste such as mineral spirits, oil and paint thinner in storm drains or sanitary sewers.
- E. Hazard Control:
 - 1. Store volatile wastes in covered metal containers, and remove from premises daily.
 - 2. Prevent accumulation of waste which might cause hazardous conditions.
 - 3. Provide adequate ventilation during use of volatile and noxious substances.

1.02 DURING CONSTRUCTION

- A. Clean building, grounds and public properties and keep free from accumulations of waste materials and rubbish.
- B. Wet down dry materials and rubbish to prevent dust.
- C. At reasonable intervals during progress of Work, but in no case less than once a week, clean site and public properties and dispose of waste materials, debris and rubbish.
- D. Provide on-site containers for collection of waste materials, debris, and rubbish.
- E. No debris shall be permitted to accumulate on site except in a container designed for debris removal.

1.03 FINAL CLEANING

- A. Remove waste, debris, and surplus materials from site. Clean grounds; remove stains, spills, and foreign substances from paved areas and sweep clean. Rake clean other exterior surfaces.
- B. Maintain cleaning until Final Completion.
- C. Prior to Final Completion, or Town occupancy, Contractor shall conduct an inspection of sight exposed interior and exterior surfaces, and all work areas, to verify that the entire work is clean.

PART 2 – PRODUCTS

N/A

PART 3 – EXECUTION

N/A

END OF SECTION

SECTION 2.11

BUY AMERICAN POLICY

PART 1 – GENERAL

1.01 REQUIREMENTS

- A. The Town shall stipulate or cause to be stipulated a provision whereby the person, firm, or corporation undertaking the project agrees to use in the execution of the contract; materials, supplies, and products manufactured, mined, processed, or otherwise produced in the United States or its territories, if the same are available at reasonable and competitive prices.

PART 2 – PRODUCTS

N/A

PART 3 – EXECUTION

N/A

END OF SECTION

SECTION 3.01

CLEARING

PART 1 – GENERAL

1.01 WORK INCLUDED

- A. Clear site of trees, shrubs, plant life, grasses and debris.
- B. Remove root system of trees and shrubs to be removed measuring three (3) inches and over at the diameter of the base.
- C. Remove rocks, boulders and other debris.

1.02 RELATED WORK

- A. Section 3.02: Structure Excavation and Backfill.
- B. Section 3.04: Finish Grading.
- C. Section 3.05: Seeding.

1.03 PROTECTION

- A. Protect existing trees, shrubs and lawn areas to receive planting, rock outcropping and other features remaining as part of final landscaping.
- B. Protect benchmarks and existing structures, roads, sidewalks, paving and curbs against damage from vehicular or foot traffic.
- C. Maintain designated temporary roadways, walkways and detours for vehicular and pedestrian traffic.

PART 2 – PRODUCTS

N/A

PART 3 – EXECUTION

3.01 PREPARATION

- A. Maintain benchmarks, monuments and other reference points. Re-establish if disturbed or destroyed at no expense to the Owner.

3.02 CLEARING

- A. Clear areas as required for access to the site excavation and performance of work.
- B. Cut down trees and shrubs within construction areas. Grub out stumps, roots, embedded rocks and boulders. Consult with Owner and Engineer before actual removal of trees and shrubs.
- C. Clear out undergrowth and deadwood, without disturbing subsoil.
- D. Do not disturb trees or roots of trees which are to remain.
- E. Remove any damaged branches on trees which are to remain.

3.03 BACKFILLING AND SURFACE PREPARATION

- A. Backfill and compact all depressions resulting from clearing and grubbing with suitable materials in accordance with Section 3.09.
 - 1. Backfill embankment areas to natural ground elevation.
 - 2. Backfill excavation areas below finished subgrade to finished subgrade.
- B. Perform backfilling a satisfactory time period ahead of construction operations.
- C. Prepare areas designated on the Drawings to receive erosion controls to smooth surfaces that have been shaped, in accordance with the Drawings.

3.04 REMOVAL OF DEBRIS

- A. Promptly remove cleared debris from site. Burning or burying on site is not permitted.
- B. Obtain permission from applicable regulatory authority for disposal of debris to waste disposal site.

END OF SECTION

SECTION 3.02

STRUCTURE EXCAVATION AND BACKFILL

PART 1 – GENERAL

1.01 WORK INCLUDED

- A. Excavate for structures and stockpile soil on site for later use.
- B. Cap off and seal discontinued utility service and remove portions of lines within excavated areas.
- C. Shore and brace excavations as required.
- D. Place and compact fills to final elevations.
- E. Dewater excavations as required.

1.02 RELATED WORK

- A. Section 3.01: Clearing.
- B. Section 3.04: Finish Grading.
- C. Section 3.09: Trenching, Backfilling and Compaction for Utilities.

1.03 PROTECTION

- A. Protect trees, shrubs and lawns, rock outcroppings and other features remaining as a part of the final landscaping.
- B. Protect benchmarks, structures, fences, roads, sidewalks and curbs against damage from equipment and vehicular traffic.
- C. Protect excavations by shoring, bracing, sheet piling, underpinning or other methods, as required to prevent cave-ins or loose dirt from falling into excavations.
- D. Underpin adjacent structures, which may be damaged by excavation work, including service line and pipe chases.
- E. Notify Engineer of unexpected subsurface conditions and discontinue work in area until Engineer provides notifications to resume work.
- F. Protect bottom of excavations and soil beneath and around foundations from frost.

- G. Grade around excavations to prevent surface water runoff into excavated area. Keep excavation free of water at all times. Provide drainage and/or sump pumps as required.
- H. All blasting shall conform to local codes and laws.

PART 2 – PRODUCTS

2.01 FILL MATERIALS

- A. Crushed stone backfill: ASTM D448, size 6.
- B. Earth fill and backfill materials: Clean earth (free from organic material, cinders, ice and rocks over two (2) inches in longest dimension). When compacted, the earth fill and backfill material shall have a minimum dry density of 95 pounds per cubic feet.
- C. Subsoil: Free from roots, rock larger than three (3) inches in size or building debris.
- D. Fill under landscaped areas: Free from alkali, salt and petroleum products. Use subsoil excavated from site only if conforming to specified requirements.

PART 3 – EXECUTION

3.01 PREPARATION AND LAYOUT

- A. Establish extent of excavation by area and elevation; designate and identify datum elevations.
- B. Maintain benchmarks, monuments, and other reference points. Re-establish if disturbed or destroyed, at no cost to the Owner.
- C. Layout and verify grades. Prior to construction, gravity sewer must be staked and cut sheets prepared by a registered surveyor acceptable to the Engineer. If discrepancies exist between actual lines and elevations and those indicated on the Drawings, notify the Engineer.

3.02 UTILITIES

- A. Before starting excavation, establish location and extent of underground utilities occurring within the work area.
- B. Notify utility companies to remove and relocate lines that are in the way of excavation.
- C. Maintain, re-route or extend as required existing utility lines to remain which pass through the work area.

- D. Pay cost for this work, except those covered by utility companies.
- E. Protect utility services uncovered by excavation.
- F. Remove abandoned utility service lines from areas of excavation; cap, plug or seal such lines and identify at grade.
- G. Accurately locate and record abandoned and active utility lines rerouted or extended, on Project Record Documents.

3.03 EXCAVATION

- A. Have the Engineer inspect all foundation excavations prior to placement of concrete.
- B. Excavate subsoil in accordance with lines and levels required for construction of the work, including space for forms, bracing and shoring, foundation drainage system, waterproofing and to permit inspection.
- C. Perform additional excavation only by written authorization of the Engineer.
- D. Machine slope banks.
- E. Hand trim excavations and leave free from loose or organic matter.
- F. When complete, verify soil bearing capacities, depths and dimensions.
- G. Correct unauthorized excavation as directed, at no cost to the Owner.
- H. Fill over-excavated areas under structure bearing surfaces with concrete as specified for foundations. Fill over-excavated areas under slabs on grade with No. 6 crushed stone.
- I. Excavations are not to interfere with normal 45 degree bearing splay of any foundation.
- J. Stockpile excavated sub-soil for re-use where directed. Remove unsuitable excavated subsoil from site. Remove excess excavated materials from site.
- K. Where rock is encountered during excavation, remove as necessary to provide foundation system indicated. Dispose of excavated rock offsite.

3.04 FILL AND BACKFILLING

- A. Stockpile fill materials in areas designated by the Engineer.
- B. Ensure areas to be backfilled are free from debris, snow, ice and water, and that ground surfaces are not in a frozen condition.
- C. Do not backfill over existing subgrade surfaces which are porous, wet or spongy.
- D. Cut out soft areas of existing subgrade. Backfill with compacted earth.
- E. Fill and backfill to grades, contours, levels and elevations as indicated on the Drawings.
- F. Maintain optimum moisture content of backfill materials to attain required compaction density.
- G. Fills shall be shaped to provide natural drainage and shall be sealed at the end of each days work or during precipitation.
- H. Sealed fills shall be scarified before placing the next layer.

3.05 SURPLUS MATERIAL

- A. Remove surplus materials from site.
- B. Leave stockpile areas completely free of all excess fill materials.

END OF SECTION

SECTION 3.03

EROSION CONTROL

PART 1 – GENERAL

1.01 DESCRIPTION

- A. This work shall consist of erosion control on all cut and fill operations, excavation, backfill, or other construction activities within the limits of the construction site, within any temporary or permanent easements, and within any borrow site used during the period of construction. The protection of these sites shall continue throughout the construction period. During flood seasons, protect the sites by sandbagging, the pumping of water, and any other means appropriate to restrain flooding of plant and equipment. During dry weather, sprinkle the sites with water or use other means as necessary to provide dust control. In case of abnormally cold weather, any construction such as excavation work may be delayed until warmer weather or covered to prevent freezing.
- B. The temporary pollution control provisions contained herein shall be coordinated with the permanent erosion control features, to ensure economical, effective, and continuous erosion control throughout the construction and post-construction period.
- C. Contractor shall be responsible for obtaining permits and adhering to the erosion control standards as set forth by the State of Tennessee.

PART 2 – PRODUCTS

2.01 TEMPORARY BERMS

- A. A temporary berm is constructed of compacted soil, with or without a shallow ditch, at the top of fill slopes or transverse to centerline on fills.
- B. These berms are used temporarily at the top of newly constructed slopes to prevent excessive erosion until permanent controls are installed or slopes stabilized.

2.02 TEMPORARY SLOPE DRAINS: A temporary slope drain is a facility consisting of stone gutters, fiber mats, plastic sheets, concrete or asphalt gutters, half round pipe, metal pipe, plastic pipe, sod, or other material that may be used to carry water down slopes to reduce erosion.

2.03 SEDIMENT STRUCTURES: Sediment basins, ponds, and traps, are prepared storage areas constructed to trap and store sediment from erodible areas in order to protect properties and stream channels below the construction areas from excessive siltation.

- 2.04 CHECK DAMS: Check dams are barriers composed of large stones, sand bags, or other non-corrodible materials placed across or partially crossing a natural or constructed drain way.
- 2.05 TEMPORARY SEEDING AND MULCHING: Temporary seeding and mulching are measures consisting of seeding, mulching, fertilizing, and matting utilized to reduce erosion. All cut and fill slopes including waste sites and borrow pits shall be seeded when and where necessary to eliminate erosion.
- 2.06 BALED HAY OR STRAW CHECKS
- A. Baled hay or straw erosion checks are temporary measures to control erosion and prevent siltation. Bales shall be either hay or straw containing five (5) cubic feet or more of material.
- B. Baled hay or straw checks shall be used where the existing ground slopes toward or away from the embankment along the toe of slopes, in ditches, or other areas where siltation erosion or water runoff is a problem.
- 2.07 TEMPORARY SILT FENCES: Silt fences are temporary measures utilizing woven wire or other approved material attached to posts with filter cloth imposed or burlap, plastic filter fabric, etc., attached to the upstream side of the fence to retain the suspended silt particles in the runoff water.

PART 3 – EXECUTION

- 3.01 PROJECT REVIEW: Prior to the Preconstruction Conference the Contractor shall go over in detail the expected problem areas in regard to the erosion control work. It is the basic responsibility of the Contractor to develop an erosion control plan acceptable to the Town and the State of Tennessee.
- 3.02 The Contractor shall maintain a spill prevention plan. The contents of this spill prevention plan shall depend on what types of chemicals, lubricants and fuels will be used and if these will be stored on site. As a minimum, if fuel or lubricants or other chemicals are stored on site, either temporarily in vehicular tanks or in skid or trailer mounted tanks, a plan shall be supplied which directs all employees of the Contractor in the proper procedures to be followed should a spill occur. For more complex chemical storage requirements, a more complex plan will be required.
- 3.03 PRECONSTRUCTION CONFERENCE: At the Preconstruction Conference, the Contractor shall submit for acceptance his schedule for accomplishment or temporary and permanent erosion control work, as are applicable for the utility construction.

3.04 CONSTRUCTION REQUIREMENTS

- A. The Town has the authority to limit the surface area of erodible earth material exposed by the utility construction, and to direct the Contractor to provide immediate permanent or temporary pollution control measures to prevent contamination of adjacent streams or other watercourses, lakes, ponds, or other water impoundment. Such work may involve the construction of temporary berms, dikes, dams, sediment basins, slope drains, and use of temporary mulches, mats seeding or other control devices or methods as necessary to control erosion. Cut and fill shall be seeded and mulched as the excavation proceeds.
- B. The Contractor shall be required to incorporate all permanent erosion control features into the project at the earliest practicable time as outlined in his accepted schedule. Temporary pollution control measures shall be used to correct conditions that develop during construction that were not foreseen during the preconstruction stage; that are needed prior to installation of permanent pollution control features; or that are needed temporarily to control erosion that develops during normal construction practices, but are not associated with permanent control features on the project.
- C. Where erosion is likely to be a problem, clearing and grubbing operations should be so scheduled and performed that grading operations and permanent erosion control features can follow immediately thereafter if the project conditions permit; otherwise erosion control measures may be required between successive construction stages. Under no conditions shall the erodible earth material exposed at one time by clearing and grubbing exceed 5,000 linear feet for linear utility work or twenty-five (25) acres for other clearing and grubbing operations (i.e. subdivisions).
- D. The Town will limit the area of excavation in progress commensurate with the Contractor's capability and progress in keeping the finish grading, mulching, seeding, and other such permanent pollution control measures current in accordance with the accepted schedule. Should seasonal limitations make such coordination unrealistic, temporary erosion control measures shall be taken immediately to the extent feasible and justified.
- E. In the event of conflict between these requirements and pollution control laws, rules or regulations, or other Federal, State or Local agencies, the more restrictive laws, rules, or regulations shall apply.

3.06 CONSTRUCTION OF STRUCTURES

- A. Temporary Berms
 - 1. A temporary berm shall be constructed on compacted soil, with a minimum width of 24 inches at the top and a minimum height of 12 inches, with or without a shallow ditch, constructed at the top of fill slopes or transverse to centerline on fills. Temporary berms shall be graded so as to drain to a

compacted outlet at a slope drain. The area adjacent to the temporary berm in the vicinity of the slope drain must be properly graded to enable this inlet to function efficiently and with only minimum ponding in this area. All transverse berms required on the downstream side of a slope drain shall extend across the grade to the highest point at approximately a ten (10) degree angle with a perpendicular to centerline. The top width of these berms may be wider and the side slope flatter on transverse berms to allow equipment to pass over these berms with minimal disruptions. When practical and until final roadway elevations are approached, embankments should be constructed with a gradual slope to one side of the embankment to permit the placement of temporary berms and slope drains on only one side of the embankment.

B. Temporary Slope Drains

1. Temporary slope drains shall consist of stone gutters, fiber mats, plastic sheets, concrete or asphalt gutters, half round pipe, metal pipe, plastic pipe, flexible rubber, or other materials which can be used as temporary measures to carry water accumulating in the cuts and on the fills down the slopes prior to installation of permanent facilities or growth of adequate ground cover on the slopes.
2. Fiber matting and plastic sheeting shall not be used on slopes steeper than 4:1 except for short distances of 20 feet or less.
3. All temporary slope drains shall be adequately anchored to the slope to prevent disruption by the force of the water flowing in the drains. The base for temporary slope drains shall be compacted and concavely formed to channel the water or hold the slope drain in place. The inlet end shall be properly constructed to channel water into the temporary slope drain. Energy dissipater would be dumped rock or a small sediment basin which would slow the water as well as pick up some sediment. All temporary slope drains shall be removed when no longer necessary and the site restored to match the surroundings.

C. Sediment Structures

1. Sediment structures shall be utilized to control sediment at the foot of embankments where slope drains outlet; at the bottom as well as in the ditch lines atop waste sites; and in the ditch lines or borrow pits. Sediment structures may be used in most drainage situations to prevent excessive siltation of pipe structures. All sediment structures shall be at least four times as long as they are wide or at least have a flow path as long as possible.
2. When use of temporary sediment structures is to be discontinued, all sediment accumulation shall be removed, and all excavation backfilled and properly compacted. The existing ground shall be restored to its natural and intended condition.

- D. Check Dams
 - 1. Check dams shall be utilized to retard stream flow or restrict stream flow within the channel. Materials utilized to construct check dams are varied and should be clearly illustrated or explained in the Contractor's erosion control plan.
 - 2. All check dams shall be keyed into the sides and bottom of the channel.
- E. Temporary Seeding and Mulching: Seeding and mulching shall be performed in accordance with the Section 3.05 - Seeding. Seeding and mulching shall occur as soon as practical but no more than 10 working days.
- F. Baled Hay or Straw Erosion Checks: Hay or straw erosion checks shall be embedded in the ground four (4) to six (6) inches to prevent water flowing under them. The bales shall also be anchored securely to the ground by wooden stakes driven through the bales into the ground. Bales can remain in place until they rot, or be removed after they have served their purpose. The Contractor shall keep the checks in good condition by replacing broken or damaged bales immediately after damage occurs. Normal debris cleanout will be considered routine maintenance.
- G. Temporary Silt Fences
 - 1. Temporary silt fences shall be placed on the natural ground, at the bottom of fill slopes, in ditches, or other areas where siltation is a problem. Silt fences are constructed of wire mesh fence with a covering of burlap or some other suitable material on the upper grade side of the fence and anchored into the soil.
 - 2. The Contractor shall be required to maintain the silt fence in a satisfactory condition for the duration of the project. The silt accumulation at the fence may be left in place and seeded or removed. The silt fence remains the property of the Contractor whenever the fence is removed.
- H. Under no circumstances shall spent oil wastes be discharged on the site.

3.07 MAINTENANCE

- A. The temporary erosion control features installed by the Contractor shall be acceptably maintained by the Contractor until no longer needed or permanent erosion control methods are installed. Any materials removed shall become the property of the Contractor.

- 3.08 EROSION CONTROL OUTSIDE PROJECT AREA: Temporary pollution control shall include construction work outside the project area where such work is necessary as a result of construction such as borrow pit operations, haul roads, and equipment storage sites.

END OF SECTION

SECTION 3.04

FINISH GRADING

PART 1 – GENERAL

1.01 SECTION INCLUDES

- A. The work called for by this section shall include, but not necessarily be limited to, finish grading and the spreading and shaping of topsoil to the finished contour elevations indicated by the drawings.

PART 2 – PRODUCTS

2.01 TOPSOIL

- A. Use stripped topsoil that has been stockpiled. If the quantity of topsoil on the job is inadequate, furnish enough additional topsoil. Topsoil furnished shall be natural, fertile, friable soil possessing characteristics of representative productive solids in the vicinity. It shall be obtained from naturally well drained areas. It shall not be excessively acid or alkaline nor contain toxic substances that may be harmful to plant growth. Topsoil shall be without admixture of subsoil and shall be cleaned and reasonably free from clay, lumps, stones, stumps, roots, or similar substances 2” or more in diameter, debris, or other objects that are a hindrance to planting operations. Such material shall be subject to testing.

PART 3 – EXECUTION

3.01 GRADING

- A. Do not begin work until the earth is dry enough to be tillable.
- B. Inspect subgrades to see that they generally conform to the standards called for elsewhere in these specifications, particularly with regard to the approximate depths required for the work. After work is completed, inspect it to ensure that all finish grading complies with design requirements.
- C. Finish grade all areas to the depths required for the work as follows:
 - 1. Grade uniformly with rounded surfaces at the tops and bottom of abrupt changes of planes.
 - 2. Hand grade steep slopes and areas that are inaccessible for machine work.
 - 3. Protect graded areas from undue erosion, and repair and regrade areas where erosion does occur.
 - 4. Refill areas where noticeable settlement has occurred.

5. Finish grade areas that are to receive topsoil up to 4" below the finished contour elevations called for by the drawings or, over rock, to 12" below these elevations.
- D. Place topsoil uniformly over disturbed areas that do not receive other work as follows:
1. Scarify subgrade to a depth of 3".
 2. Place the topsoil to a depth of 4" when lightly rolled or, on rock, to a depth of 12".
 3. Level the topsoil so that it slopes uniformly and has no water pockets.
 4. Carefully rake the topsoil by hand to remove all clods, roots, sticks, stones over 1" in diameter, and other foreign materials from the surface.
- E. Dispose of excess excavated materials and debris away from the site.

END OF SECTION

SECTION 3.05

SEEDING

PART 1 – GENERAL

- 1.01 This work shall be performed in all disturbed areas not receiving such site improvements as buildings, roads, walks, sod, planting, etc., and shall include, but not necessarily be limited to, all seed bed preparation; the supplying and placing of soil additives, seed, and mulch and maintenance.
- 1.02 Refer to other sections for items affecting seeding. Coordinate this work with that specified by other sections for timely execution.

PART 2 – PRODUCTS

2.01 MATERIALS

- A. **GRASS SEED:** Kentucky 31 Fescue (*Festuca elatior*) and/or annual rye meeting the requirements of the State Department of Agriculture and furnished in new bags or bags that are sound and not mended; no “below standard” seed will be accepted.
- B. **FERTILIZER:** Commercially manufactured; Grade 10-10-10; furnished in standard containers that are clearly marked with the name, weight, and guaranteed analysis of the contents and that ensure proper protection in transportation and handling; and in compliance with all local, state, and federal fertilizer laws.
- C. **AGRICULTURAL LIMESTONE:** Containing a minimum of 85% calcium carbonate and magnesium carbonate combined, 85% of which passes a No. 10 mesh sieve.
- D. **MULCH:** Stalks of rye, oats, wheat, or other approved grain crops properly cured prior to baling, air dried, and reasonably free of noxious weeds and weed seeds or other material detrimental to plant growth.

PART 3 – EXECUTION

3.01 SEEDING

- A. Perform all seeding and related work as a continuous operation. Sow seed as soon as the seed bed has been prepared, and perform subsequent work in a continuous manner
- B. Before beginning seeding operations in any area, complete the placing of topsoil and final grading.

- C. Scarify, disk, harrow, rake, or otherwise work each area to be seeded until the soil has been loosened and pulverized to a depth of not less than two (2) inches. Perform this work only when the soil is in a tillable and workable condition.
- D. Apply fertilizer and agricultural limestone uniformly over the seed bed, and lightly harrow, rake, or otherwise incorporate them into the soil for a depth of approximately one (1) inch at the following rates:
 - Fertilizer: 40 pounds per 1,000 square feet
 - Agricultural Limestone: 80 pounds per 1,000 square feet
- E. Sow seed uniformly with a rotary seeder, wheelbarrow seeder, hydraulic equipment or by other satisfactory means.
- F. The seeding rate shall be five (5) pounds per 1,000 square feet for Kentucky 31 Fescue (*Festuca elatior*).
- G. For temporary stabilization seeding rate shall be three (3) pounds per 1,000 square feet of annual rye grass.
- H. Perform no seeding during windy weather or when the ground surface is frozen, wet, or otherwise untillable.
- I. When seeding with mulch is specified spread mulch material evenly over the seeded areas immediately following the seeding operation.
 - Mulch Rate: Two (2) bales (100 pound minimum) per 1,000 square feet
- J. The mulch rate may be varied, depending on the texture and condition of the mulch material and the characteristics of the area seeded. Cover all portions of the seeded areas with a uniform layer of mulch so that approximately 25% of the ground is visible.
- K. No equipment, material storage, construction traffic, etc., will be permitted on newly seeded ground.

3.02 INSPECTIONS

- A. The Town shall inspect the seeding within 60 days after planting and determine if it is acceptable.

3.03 GUARANTIES

- A. Secure an acceptable growth of grass in all areas designated for seeding.

- B. An area is considered acceptable if it is represented by a minimum of 100 seedlings per square foot of the permanent species of grass representative of the seed mixture. If an acceptable growth is not obtained on the first planting, reseeding and remulching will be required.
- C. If the planting is less than 50% successful, rework the ground, refertilize, reseed, and remulch.

END OF SECTION

SECTION 3.06

UNCLASSIFIED EXCAVATION FOR UTILITIES

PART 1 – GENERAL

1.01 SECTION INCLUDES

- A. The work called for by this section shall consist of clearing and grubbing, loosening, loading, removing, and disposing of, in the specified manner, all wet and dry materials encountered that must be removed for construction purposes; furnishing, placing, and maintaining all sheeting, shoring, bracing, and timbering necessary for the proper protection and safety of the work, the workmen, the public, and adjacent property and improvements; the dewatering of trenches and other excavations; the preparation of fills and embankments; the removal of unsuitable material from outside the normal limits of excavation and, where ordered by the Engineer, their replacement with suitable materials; and all other grading or excavation work incidental to or necessary for the work. This work shall be performed as specified below.

1.02 QUALITY ASSURANCE

- A. Codes and Standards: Perform excavation work in compliance with applicable requirements of governing authorities having jurisdiction.

1.03 JOB CONDITIONS

- A. Existing Utilities: Locate existing underground utilities in areas of work. If utilities are to remain in place, provide adequate means of support and protection during earthwork operations.
- B. Should uncharted, or incorrectly charted, piping or other utilities be encountered during excavation, consult utility owner immediately for directions. Cooperate with Owner and utility companies in keeping respective services and facilities in operation. Repair damaged utilities to satisfaction of utility owner.
- C. Do not interrupt existing utilities serving facilities occupied and used by Town or others, during occupied hours, except when permitted in writing by Town and then only after acceptable temporary utility services have been provided.
 - 1. Provide minimum of 48-hour notice to Town before interrupting any utility.
- D. Demolish and completely remove from site existing underground utilities indicated to be removed. Coordinate with utility companies for shut-off of services if lines are active.

- E. Preserve from damage surveying monuments, property pins, and similar items. If disturbed or damaged by construction operations, pay the cost of restoration by a registered surveyor.
- F. Protect structures, utilities, sidewalks, pavements, and other facilities from damage caused by settlement, lateral movement, undermining, wash-out and other hazards created by earthwork operations.

1.04 PROTECTION

- A. Protect excavations by shoring, bracing, sheet piling, underpinning, or other methods required to prevent cave-in or loose soil from falling into excavation work.
- B. Underpin adjacent structures which may be damaged by excavation work, including service utilities and pipe chases.
- C. Notify Town and Engineer of Record of unexpected subsurface conditions and discontinue work in affected area until notification to resume work.
- D. Protect bottom of excavations and soil adjacent to and beneath foundations from frost.
- E. Grade excavation bottoms against freezing when atmospheric temperature is less than 35°F.
- F. Protect trees, shrubbery, fences, poles, and all other property and surface structures during construction operations. Fences, poles, or other man made surface improvements which are moved or disturbed shall be restored to the original conditions after construction is completed. Trees, shrubbery, or other vegetation which are approved for removal in order to facilitate construction operations shall be removed completely, including stumps and main roots. Responsibility for damage or claims for damage caused by construction operations to shrubbery or other landscape improvements shall be assumed by Contractor.

1.05 SAFETY

- A. Barricades, Guards, and Safety Provisions: Place and maintain barricades, fences, construction signs, torches, flashing lights, lanterns, guards, and flagmen as required during the progress of the construction work and until it is safe for traffic to use the roads and streets. Material piles, equipment, and pipe which may serve as obstructions to traffic shall be enclosed by fences or barricades and shall be protected by proper lights when the visibility is poor. The rules and regulations of OSHA and appropriate authorities respecting safety provisions shall be observed.
- B. Structure Protection: Provide temporary support, protection, and maintenance of underground and surface drains, sewers, and other obstructions encountered during

the progress of the work. Structures which may have been disturbed shall be restored upon completion of the work.

1.06 DEVIATIONS OCCASIONED BY STRUCTURES OR UTILITIES

- A. Wherever obstructions are encountered during the progress of the work which occupy the space required for the pipeline, Town shall have the ability to order a deviation from the line and grade.
- B. Where gas, water, telephone, electrical, or other existing utilities directly interfere with the vertical or horizontal alignment of the pipeline, Town will order a change in grade or alignment.

1.07 MAINTENANCE OF THE TRAFFIC AND CLOSING OF STREETS

- A. Carry on the work in a manner which will cause a minimum of interruption to traffic, and do not close to through travel more than two consecutive blocks, including the cross street intersected. Where traffic must cross open trenches, provide bridges at street intersections and driveways. Post signs indicating that a street is closed and necessary detour signs for the proper maintenance of traffic. Before closing any streets notify responsible municipal authorities.

PART 2 – PRODUCTS

2.01 SOIL MATERIALS

- A. Satisfactory soil materials are defined as those complying with ASTM D2487 unified soil classification system groups GW, GP, GM, SM, SW and SP.
- B. Unsatisfactory soil materials are defined as those complying with ASTM D2487 unified soil classification system GC, SC, ML, MH, CL, CH, OL, OH and PT.
- C. Drainage Fill: Washed, evenly graded mixture of crushed stone, or crushed or uncrushed gravel, with 100% passing a 1-1/2” sieve and not more than 5% passing a No. 4 sieve.
- D. Backfill and Fill Materials: Satisfactory soil material of clay, rock, or gravel not larger than 2” in any dimension, free of debris, waste, frozen materials, vegetable and other deleterious matter.

PART 3 – EXECUTION

3.01 PREPARATION OF THE SITE

- A. Before starting construction, remove from the work site all vegetable growth (except as hereinafter excluded), debris, and/or other objectionable matter as well as any

buildings and/or other structures that the Construction Documents specifically indicate are to be removed.

- B. In certain areas it may be desirable for existing trees, shrubs, or other vegetation on the site to be preserved for the permanent landscape. Such vegetation may be specifically listed in the specifications, marked on the site, or identified by the Engineer. In no case damage or remove such growth without written permission from the Engineer.
- C. If the area to be excavated is occupied by trees, brush, or other vegetable growth, clear such growth and grub the excavated area and remove all large roots to a depth of not less than 2' below the bottom of the proposed construction. Dispose of the growth removed. Fill all holes or cavities created during this work that extend below the subgrade elevation with suitable material, and compact to the same density as the surrounding material.
- D. Trees, cultivated shrubs, etc., that are situated within public rights-of way and/or construction easements through private property but not directly within the excavation area shall remain undisturbed unless it is necessary to remove them so that the work can be performed safely. Take special precautions to protect and preserve such growth throughout all stages of the construction.

3.02 EXCAVATION

- A. Excavation is unclassified, and includes excavation to subgrade elevations.

3.03 UNSUITABLE MATERIALS

- A. Whenever muck, quicksand, soft clay, swampy ground, or other material unsuitable for foundations, subgrade, or backfilling is encountered, remove it and continue excavation until suitable material is encountered. The material removed shall be disposed of in the manner described below. Then refill the areas excavated for this reason with 1" to 2" crushed stone up to the level of the lines grades, and/or cross sections shown on the drawings. The top 6" of the refill shall be No. 67 (TDOT) crushed stone for bedding.

3.04 ROCKS AND BOULDERS

- A. Any material that is encountered within the limits of the required excavation that cannot be removed except by drilling and/or blasting, including rock, boulders, masonry, hard pan, chert, shale, street and sidewalk pavements, and/or similar materials, shall be considered as rock excavation. Rock material shall be considered where it cannot be removed by a trackhoe by ripping the material.
- B. Should rock be encountered in the excavation, remove it by blasting or otherwise. Where blasts are made, cover the excavation with enough excavation material and/or

timber or steel matting to prevent danger to life and property. The Contractor shall secure, at his own expense, all permits required by law for blasting operations and the additional hazard insurance required. Observe all applicable laws and ordinances pertaining to blasting operations.

- C. Excavate rock over the horizontal limits of excavation to a depth of not less than 6” below the bottom of pipe up to 30” in diameter and not less than 12” below the bottom of larger pipes if rock extends to such depth. Then backfill the space below grade with No. 67 (TDOT) Crushed stone, tamp to the proper grade, and make ready for construction.

3.05 DISPOSAL OF MATERIALS

- A. Whenever practicable, all materials removed by excavation that are suitable for backfilling pipe trenches or for other purposes shown on the drawings or directed by the Town shall be used for these purposes. Any materials not so used shall be considered waste materials and disposed of by the Contractor as specified below.
- B. Once any part of the work is completed, properly dispose of all surplus or unused materials (including waste materials) left within the construction limits of that work. Leave the surface of the work in a neat and workmanlike condition, as described below.

3.06 SHEETING, SHORING AND BRACING

- A. Take special care to avoid damage wherever excavation is being done. Sufficiently sheet, shore, and brace the sides of all excavations to prevent slides, cave-ins, settlement, or movement of the banks and to maintain the specified trench widths. Use solid sheets in wet, saturated, or flowing ground. All sheeting shoring and bracing shall have enough strength and rigidity to withstand the pressures exerted, to keep the walls of the excavation properly in place, and to protect all persons and property from injury or damage. Separate payment will not be made for sheeting, shoring, and bracing, which are considered an incidental part of the excavation work.
- B. Wherever employees may be exposed to moving ground or cave-ins, shore and lay back exposed earth excavation surfaces more than 5’ high to a stable slope, or else provide some equivalent means of protection. Effectively protect trenches less than 5’ deep when examination of the ground indicates hazardous ground movement may be expected. Guard the wall and faces of all excavations in which employees are exposed to danger from moving ground by a shoring system, sloping of the ground, or some equivalent protection.
- C. Comply with all OSHA standards in determining where and in what manner sheeting, shoring, and bracing are to be done. The sheeting, shoring, and bracing system shall be designed by a professional engineer licensed in the State of Tennessee. However, such approval does not relieve the Contractor of the sole

responsibility for the safety of all employees, the effectiveness of the system, and any damages or injuries resulting from the lack or inadequacy of sheeting, shoring, and bracing.

- D. Where excavations are made adjacent to existing buildings or structures or in paved streets or alleys, take particular care to sheet, shore, and brace the sides of the excavation so as to prevent any undermining of or settlement beneath such structures or pavement. Underpin adjacent structures wherever necessary.
- E. Do not leave sheeting, shoring, or bracing materials in place unless this is called for by the drawings, ordered by the Owner, or deemed necessary or advisable for the safety or protection of the new or existing work or features. Remove these materials in such a manner that the new structure or any existing structures or property, whether public or private, will not be endangered or damaged and the cave-ins and slides are avoided.
- F. Fill and compact all holes and voids left in the work by the removal of sheeting, shoring, or bracing as specified herein.
- G. The Contractor may use a trench box, which is a prefabricated movable trench shield composed of steel plates welded to a heavy steel frame. The trench box shall be designed to provide protection equal to or greater than that of an appropriated shoring system.
- H. Dewatering: Prevent surface water and subsurface or ground water from flowing into excavations and from flooding project site and surrounding area.
- I. Do not allow water to accumulate in excavations. Remove water to prevent softening of subgrade foundation bottoms, undercutting footings, and soil changes detrimental to stability of subgrades and foundation. Provide and maintain pumps, well points sumps, suction and discharge lines, and other dewatering system components to convey water away from excavations.
- J. Establish and maintain temporary drainage ditches and other diversions outside excavation limits to convey rain water removed from excavations to collecting or run-off areas. Do not use trench excavations as temporary drainage ditches.

3.08 BORROW EXCAVATION

- A. Whenever the backfill of excavated areas or the placement of embankments requires more material than is available from authorized excavations, or whenever the backfill material from such excavations is unsuitable, obtain additional material from other sources. This may require the opening of borrow pits at points accessible to the work. Before a borrow pit is opened, the quality and suitability of its material shall be approved by the Town.

- B. Properly clear and grub borrow pits, and remove all objectionable matter from the borrow pit materials before placing it in the backfill.

3.09 BACKFILLING

- A. Conduct backfilling around manholes, inlet, outfalls, and/or structures in the same manner as specified for water lines, gravity sewers and/or force mains except that even greater care is necessary to prevent damage to the utility structure.
- B. Perform backfilling so as not to disturb or injure any pipe and/or structure against which the backfilling is being placed. If any pipe or structure is damaged and/or displaced during backfilling, open up the backfill and make whatever repairs are necessary.

3.10 MAINTENANCE

- A. Seed and maintain in good condition all excavated areas, trenches, fills, embankments, and channels until final acceptance by the Town.
- B. Maintain trench backfill at the approximate level of the original ground surface by periodically adding backfill material wherever necessary and whenever directed to do so by the Town. Continue such maintenance until final acceptance of the project or until Town issues a written release.

END OF SECTION

SECTION 3.07

DEMOLITION

PART 1 – GENERAL

1.01 SUMMARY

- A. Section Includes: Selective removal and subsequent disposal of utilities, pavements, portions of buildings, and other items indicated to be removed.
- B. Extent of demolition work is indicated on Contract Drawings.

1.02 REFERENCES

- A. Code of Federal Regulations (CFR)
 - 1. 29 CFR Part 1910 Occupational Safety and Health Standards
 - 2. 29 CFR Part 1926 Safety and Health Regulations for Construction

1.03 PROJECT/SITE CONDITIONS

- A. Occupancy: Conduct demolition work in a manner that will minimize need for disruption of normal operations for occupants of adjacent areas.
- B. Explosives: Use of explosives is not permitted.

PART 2 – PRODUCTS

N/A

PART 3 – EXECUTION

3.01 EXAMINATION

- A. Verify existing conditions at the site, and examine adjoining work that will affect the execution and scheduled completion of Work. If required, Contractor shall utilize detection system to locate existing underground interference.
- B. Provide written pre-demolition survey to the Town for review and approval.
- C. Verify that utilities have been disconnected and capped.

- D. If unanticipated elements conflicting with the intended function or design are encountered, investigate and measure the nature and extent of the conflict.
 - 1. Promptly submit a written report to the Town outlining the elements in conflict and extent of the conflict.

3.02 UTILITY SERVICES

- A. Maintain existing utilities indicated to remain in service and protect against damage during demolition operations.
- B. Schedule any utility outages through the Town. A minimum of two weeks notice is required.

3.03 PREPARATION

- A. Conduct demolition operations and remove debris in a manner to ensure minimum interference with roads, streets, walks, and other adjacent occupied or used facilities.
- B. Conduct demolition operations to prevent injury to people and damage to adjacent buildings and facilities designated to remain.
 - 1. Provide temporary barricades and other forms of protection as required for safety and security.
 - 2. Provide barriers and appropriate signs meeting requirements of 29 CFR 1910 for size and color where necessary to restrict pedestrians from wandering into construction areas.
- C. Provide and maintain interior and exterior shoring, bracing or structural support to preserve stability and prevent movement, settlement, or collapse of structures and adjacent facilities that are not part of demolition.

3.04 DEMOLITION

- A. General: Perform demolition work in accordance with 29 CFR 1926.
 - 1. Perform work in a safe and systematic manner.
 - 2. Use such methods as required to complete work indicated on the Contract Drawings and to minimize disturbances to occupants of adjacent properties.
- B. Demolish and remove existing construction only to extent required, and as indicated in the Contract documents.
- C. Wear proper personal protective equipment at all times.
- D. Protect adjacent properties from debris, dust and excessive noise during the execution of the work of this Section. All work shall be wet down periodically to minimize dust.

- E. Completely backfill below-grade areas and voids resulting from utility removal and other demolition work.
- F. Abandonment of Utilities
 - 1. Purge, clean, fill, or terminate utility pipelines that are to be abandoned in a manner conforming to the requirements of the nationally recognized code covering the specific utility; and as indicated on the drawings.

3.05 REPAIRS

- A. Repair demolition performed in excess of that required.
- B. Return structures, utilities, and surfaces not part of demolition to conditions existing prior to commencement of demolition work.

3.06 DISPOSAL OF DEMOLISHED MATERIALS

- A. All materials shall be disposed of in accordance with applicable laws and regulations of all agencies having jurisdiction. Contractor shall bear cost of all fees.
- B. If the Contractor encounters any materials during the removal that is suspected to be potentially hazardous, stop work immediately and notify the Town.
- C. Contractor is responsible for all removal of demolished materials to off-site disposal.
- D. Burning debris and rubbish on the property will be permitted with the property Owner's and Town's written approval. When permitted, burning shall strictly comply with applicable federal, state and local regulations. Contractor will be responsible for all applicable permits.

3.07 CLEANING

- A. Remove from the project site all materials, rubbish and other debris resulting from the demolition work. Leave the site clean and safe daily.
- B. Remove tools, equipment and demolished materials from site upon completion of demolition work.

END OF SECTION

SECTION 3.08

TRENCHING, BACKFILLING, AND COMPACTION FOR UTILITIES

PART 1 – GENERAL

1.01 REQUIREMENTS INCLUDED

- A. Excavation for buried utility material.
- B. Provide necessary sheeting, shoring and bracing.
- C. Prepare trench bottom with appropriate materials.
- D. De-water excavations as required.
- E. Place and compact granular beds, as required, and backfill.

1.02 RELATED WORK

- A.. Section 3.06: Unclassified Excavation for Utilities
- B. Section 4.01: Manholes
- C. Section 4.02: Sanitary Sewers (Gravity)
- D. Section 4.03: Sewage Force Main
- E. Section 5.01: Water Lines
- F. Section 7.02: Asphaltic Pavement Repair.
- G. Section 7.03: Portland Concrete Pavement Repair

1.03 PRECAUTIONS

- A. Contractor shall shore and brace all open cut trenches as required by State and Federal Laws and Local Ordinances; conform to recommendations set forth in AGC Manual of Accident Prevention in Construction; protect life, property, or work; and avoid excessively wide cuts in unstable material.
- B. Notify utility companies when necessary to disturb existing facilities and abide by their requirements for repairing and replacing.

- C. Protect all vegetation and other features to remain.
- D. Protect all benchmarks and survey points.

PART 2 – PRODUCTS

N/A

PART 3 – EXECUTION

3.01 PREPARATION

- A. Install barriers and other devices to protect areas adjacent to construction.
- B. Protect and maintain all benchmarks and other survey points.

3.02 EXCAVATION TRENCHES

- A. Perform in such a manner as to form a suitable trench in which to place the pipe and so as to cause the least inconvenience to the public.
- B. Maximum width at the crown of the pipe shall be 16 inches plus the nominal diameter of the pipe.
- C. Cut pavement along neat, straight lines with either a pavement breaker or pavement saw.
- D. Trench depth: To provide minimum cover as specified in Section 4.02, 5.01, 6.01, 8.01, or 9.01 over the top of the pipe.
- E. Align trench as shown on the drawings unless a change is necessary to miss an unforeseen obstruction.
- F. When unstable soil is encountered at the trench bottom, remove it to a depth required to assure support of the pipeline and backfill to the proper grade with coarse aggregate AASHTO M-43, Size No. 2 or 3.
- G. Remove rock encountered in trench excavation to a depth of six (6) inches below the bottom of the pipe barrel, backfill with an approved material, and compact to uniformly support the pipe. In no case shall solid rock exist within six (6) inches of the finished pipeline.

3.03 SHEETING, SHORING AND BRACING

- A. When necessary, furnish, put in place, and maintain such sheeting, bracing, etc., as may be required to support the sides of the excavation and to prevent movement.

- B. Take care to prevent voids outside the sheeting.
- C. If voids are formed, immediately fill and compact to the satisfaction of the Engineer.
- D. Unless adjacent facilities will be damaged, remove all sheeting, shoring, and bracing after backfill has been placed to a depth of 18 inches over the pipeline.
- E. Cut shoring off at the top of the pipe and leave the lower section in the trench.

3.04 USE OF EXPLOSIVES

- A. Conduct all blasting operations in accordance with prevailing municipal, state, or other agency regulations, codes, ordinances, or laws.
- B. Exercise due caution when blasting adjacent to existing structure and pipe lines.
- C. Cover all shots with blasting mats to prevent flying material.

3.05 DISPOSAL OF EXCAVATED MATERIAL

- A. Satisfactorily dispose of all excess excavated material that cannot be used for or is not suitable for embankments.

3.06 UNAUTHORIZED EXCAVATION

- A. Unauthorized excavation is defined as all excavation outside or below the proposed lines and grades shown on the drawings.
- B. Backfill areas of unauthorized excavation with the type material necessary (earth, rock or concrete) to insure the stability of the structure of construction involved.
- C. Unauthorized excavation or backfill to replace same shall not be a pay item.

3.07 REMOVAL OF WATER

- A. Keep excavated areas free of water while work is in progress.
- B. Well-pointing shall be performed if required.
- C. Take particular precautions to prevent the displacement of structures or pipelines as a result of accumulated water.

3.08 OBSTRUCTIONS

- A. Obstructions shown on the drawings are for information only and do not guarantee their exact locations nor that other obstructions are not present.
- B. When utilities or obstructions are not shown on the drawings but are present off the roadway at the location of the proposed pipeline route, the Contractor should notify the appropriate utility owner prior to continuing with any installation.
- C. Exercise due care in excavating adjacent to existing obstructions and do not disturb same unless absolutely necessary.
- D. In the event obstructions are disturbed, repair or replace as quickly as possible to the condition existing prior to their disturbance.
- E. Coordinate all obstruction relocation with the appropriate utility owner.

3.09 INITIAL BACKFILLING/BEDDING

- A. Do not begin backfilling before the Town has inspected the grade and alignment of the pipe, the bedding of the pipe, and the joints between the pipe. If backfill material is placed over the pipe before an inspection is made, reopen the trench in order for an inspection to be made.
- B. Perform backfilling by hand, together with tamping, until fill has progressed to 12 inches above the top of the pipe.
 - 1. Deposit No. 67 stone material (where required) or loose soil free from lumps, clods, frozen material or stones no larger than 2-inches in layers approximately six (6) inches thick. Inside roadway or paved areas, all initial backfill shall be No. 67 stone
 - 2. Compact by hand, or with manually operated machine tampers actuated by compressed air or other suitable means.
 - 3. Use tamps and machines of a suitable type which do not crush or otherwise damage the pipe.
- C. If pipe is installed in a rock trench, install a 6" bedding of No. 67 (TDOT) crushed stone below the pipe. Then add additional No. 67 stone to a point 12" above the top of the pipe.

3.10 FINAL BACKFILLING

- A. After the backfill has reached a point 12 inches or more above the top of the pipe, perform final backfilling depending upon the location of the work and danger from subsequent settlement. Where pipe is located inside roadway or paved areas, final backfilling shall be with No. 67 stone.

- B. Backfilling in Unimproved Areas:
1. Dispose of and replace all soft or yielding material which is unsuitable for trench backfill with suitable material.
 2. Deposit backfill to the surface of the ground by dragline, bulldozer, or other suitable equipment in such a manner so as not to disturb the pipe.
 3. Neatly round sufficient surplus excavated material over the trench to compensate for after settlement.
 4. Dispose of all surplus excavated material.
 5. Prior to final acceptance, remove all mounds to the elevation of the surrounding terrain.

END OF SECTION

SECTION 3.09

BORING AND CASING FOR UTILITY LINES

PART 1 – GENERAL

1.01 SECTION INCLUDES

- A. The work to be performed hereunder shall consist of the installation of a casing pipe for the purpose of installing utility lines. It shall include the excavation of a boring pit, auger boring between the points as specified on the drawings, furnishing and installing of the carrier pipe, and disposing of the excavated materials in the manner herein provided.
- B. Water lines crossing beneath paved or concrete drives shall be bored and jacked. No casing pipe is required for drives. Water line shall be installed beneath drive so that no bell or spigot is located beneath drive.

PART 2 – PRODUCTS

2.01 CASING PIPE

- A. The casing pipe shall be of steel meeting the latest approved American Railway Engineering Association “Specifications” for Pipelines for Carrying Flammable and Nonflammable Substances.” The steel casing pipe shall have minimum yield strength of 35,000 PSI and shall have the minimum wall thickness shown in the following table:

TABLE OF MINIMUM WALL THICKNESS FOR STEEL CASING PIPE
FOR E72 LOADING

<u>Carrier Pipe Diameter</u>	<u>Casing Pipe Diameter</u>	<u>Nominal Thickness</u>
4 inches	8 inches	0.250 inches
6 inches	12 inches	0.250 inches
8 inches	16 inches	0.312 inches
10 inches	20 inches	0.312 inches
12 inches	22 inches	0.312 inches
14 inches	24 inches	0.344 inches
16 inches	26 inches	0.375 inches
18 inches	30 inches	0.406 inches

- B. When the casing pipe is installed without benefit of a protective coating, the wall thickness shown above shall be increased to the nearest standard size, which is a minimum of 0.063 inches greater than the thickness shown.

- 2.02 CARRIER PIPE: The carrier pipe shall be Class 350 DIP.
- 2.03 CASING SPACERS: Casing spacers shall be Model A, painted steel spacers by Pipeline Seal and Insulator Co. or approved equal.
- 2.04 END SEALS: Ends of casing pipe shall be closed by installing a 1/8" thick synthetic rubber end seal, Model C by Pipeline Seal and Insulator Co. or approved equal.

PART 3 – EXECUTION

- 3.01 BORING: The boring shall be accomplished by means of augering to the size, line, and the grade shown on the drawings.
- 3.02 INSTALLATION OF CASING PIPE
 - A. Jack the steel casing pipe into place as the boring proceeds. Weld sections of casing pipe together to provide watertight joints.
 - B. Do not remove unacceptable casing without prior approval from the Engineer. If the removal of casing pipe is permitted, make proper provisions to prevent caving in of the earth surrounding the casing. Void spaces shall be filled with grout or flowable fill. At a minimum, abandoned bore holes shall be pumped full with grout or flowable fill.
- 3.03 INSTALLATION OF CARRIER PIPE
 - A. The carrier pipe shall be furnished by the Contractor. Upon acceptance of the casing, install the carrier pipe in the casing by jacking it through the casing.
 - B. Casing spacers shall be used to provide alignment and support of the carrier pipe inside the casing. At a minimum carrier pipe shall be supported at the midpoint of pipe joint and at 1' from each end of pipe joint (3 per pipe segment).
 - C. No wood blocking of carrier pipe will be permitted.
 - D. Where sewer pipe is installed, restrained casing spacers shall be used in order to prevent flotation of carrier pipe which might impact vertical grade alignment.
 - E. Upon completion of installing carrier pipe in casing pipe, seal both ends with end seals.
- 3.04 LAYOUT OF WORK: The Contractor will provide all layouts required to keep the bore on grade and alignment.

END OF SECTION

SECTION 3.10

TUNNELING

PART 1 – GENERAL

1.01 SECTION INCLUDES

- A. This item shall include the furnishing and installation of a tunnel with steel liner plates and carrier pipe.
- B. The Contractor shall conform to all requirements of the Tennessee Department of Transportation having jurisdiction over the tunnel operation and location.

PART 2 – PRODUCTS

2.01 TUNNEL LINER PLATE

- A. The tunnel liner shall be constructed of 12 gage, bituminous coated, galvanized, or Type 2, aluminized two or four flanged steel plates bolted together, unless the Town approves the use of an alternate material. The space between the liner and the edge of excavation shall be filled with grout placed under pressure.
- B. The steel lining shall consist of plates which have a minimum tensile strength of 42,000 psi, minimum yield of 28,000 psi, elongation at 2 inches of 30% and do not exceed 18 inches wide. Each circumferential ring shall be composed of the number and length of plates to complete the required diameter. The Contractor shall submit details of the lining for approval.
- C. All plates shall be punched for bolting on both longitudinal and circumferential seams and shall be so fabricated as to permit complete erection from the inside of the tunnel. The longitudinal seam shall be of the lap type with offset equal to gage of metal for full width of plates including flanges, and shall have staggered bolt construction, so fabricated as to allow the cross-section of the plate to be continuous through the seam. All plates shall be of uniform fabrication and those intended for one size tunnel shall be interchangeable.
- D. The material used for the construction of these plates shall be new and unused and suitable for the purpose intended. Plates shall be fabricated with material in accordance with ASTM A-819 and AASHTO M274.
- E. After the plates are formed to shape and after all holes are punched, the plates shall be galvanized on all surfaces by the hot-dip process. A coating of prime western spelter, or equal, shall be applied at the rate of not less than 2 ounces per square foot of double exposed surface. If the average spelter coating as determined from the required samples is less than the amount specified above, or if any one specimen

shows a deficiency of 0.2 ounce, the lot shall be rejected. Spelter coating shall be of first-class commercial quality free from injurious defects such as blisters, flux and uncoated spots.

- F. All nuts and bolts shall be galvanized and shall be fabricated in accordance with ASTM A-307, Grade A.
- G. Plates shall be fabricated with grout holes to facilitate grouting above and around the tunnel liner. These grout openings shall be 2" I.P.T. half couplings welded into a hold in the center corrugation of a plate and a galvanized C.I. plug shall be provided for each opening to permit tight closure after grout is pumped. All rings are to be provided with grout holes so that the spacing of holes with a maximum spacing of 18" centers at the top of the tunnel and at the top quarter points, staggered with the holes at the top.

2.02 GROUT

- A. The grout shall consist of Portland cement, water, sand and 2% approved additive (Bentonite, Septamine Seaex, Hydrocide liquid, etc.). One part Portland cement with additive shall be combined to four parts clean sand and sufficient water added to provide a grout having the consistency of thick cream when well mixed.

2.03 CARRIER PIPE

- A. The carrier pipe shall be CL350 DIP.

PART 3 – EXECUTION

3.01 EXCAVATION

- A. Excavation shall be unclassified and no distinction shall be made between rock and other materials excavated. Blasting is acceptable only with explicit written approval from the authority having jurisdiction over tunneled area.
- B. Construction of the tunnel shall be carried on in such a manner that settlement of the ground surface above the tunnel shall be held to an absolute minimum. Where ground conditions are unstable, poling plates or poling boards shall be used to prevent caving of material above the tunnel before the liner plates can be installed. Steel liner plates shall be installed as soon after the excavation is removed as possible and excavation shall not be removed more than 24" ahead of the installed liner plates. Excavation shall be carried on in such a manner that voids behind the liner plates will be held to a minimum. However, should any boulders larger than 1' in diameter be encountered, they shall be removed so that none are closer than 6" to the outer face of the liner plate. Where boulders are excavated below the invert of tunnel liner plates, the holes shall be backfilled with crushed stone (#57 or 67).

3.02 LINER PLATE

- A. When installing liner plate by the tunneling method, the excavation shall be performed in such a manner that voids between the undisturbed earth and the liner plate shall be maintained at a minimum. Any void occurring shall be filled with a Portland cement and sand grout pumped under pressure through grouting openings in the liner plate.
- B. The minimum provision for grouting openings shall be one opening in a top plate of the tunnel at locations not to exceed 54" apart. Additional plates with grouting openings are to be installed at the top quarter points on each side between the top openings. The opening shall be staggered, but shall not exceed 54" in any one line. Grout vent pipes will be required at a minimum of one per monolithic pour.

3.03 GROUTING

- A. A pump shall be provided for placing the grout which shall be capable of exerting sufficient pressure to assure the filling of all voids between the liner plate and the undisturbed ground. Minimum acceptance pressure to fill voids will be five pounds per square inch.
- B. Pumping of grout shall be done (1) at the completion of the installation of approximately each 9' of liner plate, (2) at more frequent intervals than 9' if conditions indicate the necessity, and (3) at the end of a work shift or for stopping work for any reason.

3.04 CARRIER PIPE

- A. Contractor shall jack the pipe by means of air bladders, blocks, or other suitable method. Once carrier pipe is established, Contractor shall pour lean concrete bedding for the carrier pipe.
- B. The carrier pipe shall be adequately strapped to the tunnel flanges behind each bell with 2" x ¼" stainless steel straps bolted to the liner plate flanges with ½" stainless steel bolts and nuts. Concrete bulkheads will be placed at each end of the tunnel; thickness and placement of which shall be subject to the Town's approval.

3.05 BACKFILL

- A. Sand, #57 crushed stone, or pea gravel shall be blown into the tunnel to fill the void between the inside wall of the tunnel and the outside edge of the carrier pipe to the top of the carrier pipe.

END OF SECTION

SECTION 3.11

HORIZONTAL DIRECTIONAL DRILLING

PART 1 – GENERAL

1.01 SECTION INCLUDES

- A. This section covers the work necessary for the installation of HDPE line without casing installed beneath the creeks or wetland areas.
- B. This method of installation shall only be used on a case-by-case basis and shall be pre-approved by the Town.

PART 2 – PRODUCTS

2.01 PRODUCTS

- A. The Contractor shall provide all materials, equipment, and labor for completing the subaqueous crossing and for adequate protection of the work.

PART 3 – EXECUTION

3.01 SCOPE OF WORK

- A. Fabricate, Directionally Drill and Install HDPE pipe a minimum of three feet below the bottom of various creeks or wetlands.
- B. Pressure test the pipeline creek section both before and after installation.
- C. Clean up all affected sites, and restore all areas to pre-construction or better condition.
- D. Provide complete as-built drawings for each pipeline crossing. As-builts shall include plan view and profile view.
- E. Refer to Sections 5.01 for HDPE pipe requirements.

3.02 SUBMITTALS

- A. The Contractor shall prepare a schedule for the work and submit it to the Town for approval. The schedule shall include all major tasks to be performed including the following:
 - 1. Rig mobilization and setup.
 - 2. Pipe assembly.
 - 3. Pilot hole drilling.

4. Pre-reaming.
5. Pre-testing and pigging pipe before installation.
6. Pipe pulling.
7. Pre-testing and pigging pipe after installation.
8. Restoration and demobilization.

3.03 EQUIPMENT AND MATERIALS TO BE FURNISHED BY CONTRACTOR

- A. The Contractor shall furnish all equipment and material required to complete the Scope of Work which shall include but not be limited to the following:
1. Drilling equipment.
 2. Water pumps, hoses, fittings, storage tanks, filters, hay bales, and silt fencing (as required).
 3. Drilling fluids containment, collection, cleaning and disposal equipment, and material.
 4. Fuel and lubricants
 5. Bentonite and related mixing equipment.
 6. Carrier pipe.
 7. All welding equipment and materials as required.
 8. All hydrostatic and pneumatic testing equipment and materials.
 9. Side-booms, cranes, backhoes, trucks, and other equipment and materials necessary to load and unload pipe and to support and smoothly transition the pipe while being pulled into the reamed hole.
 10. All equipment and materials necessary to restore project areas to pre-existing condition or better.

3.04 INSTALLATION

- A. General: The Contractor shall install the Creek Crossing sections of the pipeline by the horizontally drilled, directionally controlled method of construction. This method shall consist of the drilling of a pilot hole within the designed tolerances for radius requirements, followed by enlargement of the hole to accommodate the product line.
- B. Instrumentation: The Contractor will at all times provide and maintain instrumentation which will accurately locate the pilot hole position in the X, Y, and Z axis relative to ground surface. Drill fluid flow rate and pressure must also be monitored.
- C. Tolerances:
1. A smoothly drilled pilot hole shall follow the design centerline of the pipe profile and alignment described on the Drawings. At no point during the bore will the combined radii in the Plan and Profile exceed the allowable minimum radius of the pipe material manufacture.
 2. The course of the pilot hole must stay within the given right-of-way at all points along the drilled route. Contractor shall provide and use a separate

steering system employing a ground survey grid system, such as “Tru-Tracker”.

3. The Contractor shall have accurate working gages which register tensile force being used to pull the pipeline back through the reamed borehole. It is the Contractor’s responsibility to prepare the reamed out hole such that pulling aback operations do not exceed the tensile strength of the pipe. The Contractor shall provide estimated calculations for the pulling loads and allowable loads before pull back operations begin. If during the pipeline pulling process this force reaches 75 percent of the allowable load for the pipeline, the project inspector must be notified immediately. Logs must be kept intact referencing all forces exerted on the pipeline during pullback.
4. The Contractor shall provide adequate supports along the stringing area to protect the pipe and allow free movement of the pipeline during pullback.
5. During pullback operations, Contractor shall monitor roller operation and use Side-booms if required to assist movement of the pipe. Situations which could cause damage to the pipe material shall be corrected immediately. Damaged pipe shall be repaired to the satisfaction of the Town or replaced by the Contractor before pulling operations resume.

3.05 DRILLING AND MUD CUTTINGS

- A. The Horizontal Directional Drilling operation is to be operated in a manner to eliminate the discharge of water, drilling mud and cuttings to the creek or land areas involved during the construction process. Contractor shall immediately contain and clean-up any inadvertent returns. Contractor shall also provide equipment and procedure to maximize the recirculation of reuse of drilling mud to minimize waste disposal.
- B. Disposal of drilling fluids shall be the responsibility of the Contractor and shall be conducted in compliance with all relative environmental regulations, easement and work space agreements and permit requirements. All costs related to disposal shall be borne by the Contractor.
- C. Water supply is the Contractor’s responsibility, whether purchased locally, hauled in, or pumped from the creek. If pumped from the creek the Contractor must comply with the rules of the Tennessee Department of Environment and Conservation.
- D. Drilling fluids must be free of all additives that will adversely effect the environment.

3.06 ADDITIONAL TESTING

- A. After installation, the pipe shall be tested in accordance with requirements of Specification Section 5.01.

3.07 REAM AND PULL BACK

- A. Prereaming: Prereaming operating shall be conducted at the discretion of the horizontal drilling Contractor. All provisions of this specification relating to simultaneous reaming and pulling back operations shall also pertain to prereaming operations.
- B. Pulling Loads: Contractor shall be responsible for determining safe pulling loads required for proper installation. Such loads shall be minimized as required to prevent failure of the pipeline during installation.
- C. Torsion Stress: A properly sized and fully operational swivel will be installed between the reaming assembly at the end of the drill pipe, and the pipeline to restrict torsion stress from being transmitted to the pipeline.
- D. Pull Section Support: The pull section shall be supported as it proceeds during pull back so that it moves freely and the pipe material is not damaged.

3.08 CLEANUP, REPAIRS, AND RESTORATION

- A. The Contractor is responsible for leaving all areas affected by his construction activities in a condition equal to or better than the condition before construction.
- B. The Contractor shall restore area around entry and exit pits as soon as work is completed. Fill to previous existing ground elevation and grade any areas where settlement occurs due to subsidence.

END OF SECTION

SECTION 3.12

CONCRETE FOR UTILITIES

PART 1 – GENERAL

1.01 SECTION INCLUDES

- A. Furnishing and installing concrete blocking, cradles, anchors, caps, pipe protection, and/or encasement at the locations directed by the Engineer.

PART 2 – PRODUCTS

2.01 MATERIALS

- A. Concrete work shall conform to ACI 301, latest revision, as modified by the supplemental requirements below:
 - 1. Strength: The strength of concrete shall be 4,000 psi unless otherwise shown on the drawings.
 - 2. Durability: All concrete exposed to weather shall be air entrained.
 - 3. Slump: Concrete shall be proportional and produced to have a slump of three (3) inches with a one (1) inch tolerance.
 - 4. Admixtures: Air entrainment, mandatory for concrete exposed to weather, may be used. A water reducing admixture (retarding, normal, or accelerating, depending on placing temperature), may be used if approved by the Owner.
 - 5. Reinforcing Steel: Yield strength of reinforcing steel shall be 60,000 psi.

PART 3 – EXECUTION

3.01 INSTALLATION

- A. Perform concrete work in accordance with recommendations of ACI-301.

END OF SECTION

SECTION 3.13

TESTING LABORATORY SERVICES

PART 1 – GENERAL

1.01 SECTION INCLUDES

- A. Laboratory services required to perform the specified testing shall be performed by an independent testing laboratory employed by the Contractor.
 - 1. Services will be paid by Contractor.
- B. Contractor shall cooperate with the laboratory to facilitate the execution of its required services.
- C. Employment of the laboratory shall in no way relieve Contractor's obligations to perform the Work of the Contract.

1.02 QUALIFICATION OF LABORATORY

- A. Laboratory shall meet "Recommended Requirements for Independent Laboratory Qualification", published by American Council of Independent Laboratories.
- B. Laboratory shall be authorized to operate in the State of Tennessee.

1.03 REFERENCE STANDARDS

- A. ANSI/ASTM D3740 – Practice for Evaluation of Agencies Engaged in Testing and/or Inspection of Soil and Rock as Used in Engineering Design and Construction.
- B. ANSI/ASTM E329 – Standard Recommended Practice for Inspection and Testing Agencies for Concrete, Steel, and Bituminous Materials as Used in Construction.

1.04 LABORATORY RESPONSIBILITIES

- A. Laboratory shall provide qualified personnel at site after due notice and cooperate with Engineer and Contractor in performance of services.
- B. Laboratory shall perform specified inspection, sampling, and testing of products in accordance with specified standards.
- C. Laboratory shall ascertain compliance of materials and mixes with requirements of Contract Documents.
- D. Laboratory shall promptly notify Engineer and contractor of observed irregularities or non-conformance of Work or products.

- E. Laboratory shall perform additional inspections and tests required by Engineer and authorized by Owner.
- F. Laboratory shall attend preconstruction conferences.

1.05 LABORATORY REPORTS

- A. After each inspection and test, Laboratory shall promptly submit two copies of laboratory reports to Town and two copies to Contractor.
- B. Each report shall include:
 - 1. Date issued.
 - 2. Project Title and number
 - 3. Testing laboratory name, address and telephone number.
 - 4. Name of laboratory inspector and job number.
 - 5. Date and time of sampling or inspection.
 - 6. Record of temperature and weather conditions.
 - 7. Date of test.
 - 8. Identification of specification section.
 - 9. Location of sample or test in the Project.
 - 10. Type of inspection or test.
 - 11. Results of tests and compliance with Contract Documents.
 - 12. Interpretation of test results.

1.06 LIMITS ON TESTING LABORATORY AUTHORITY

- A. Laboratory may not release, revoke, alter, or enlarge on requirements of Contract Document.
- B. Laboratory may not approve or accept any portion of the Work.
- C. Laboratory may not assume any duties of Contractor.
- D. Laboratory has no authority to stop Work.

1.07 CONTRACTOR RESPONSIBILITIES

- A. Cooperate with laboratory personnel, and provide access to Work.
- B. Provide incidental labor and facilities to provide access to work to be tested, to obtain and handle samples at the site or at source of products to be tested, to facilitate tests and inspections, and for storage and curing of test samples.
- C. Notify Engineer and laboratory 48 hours prior to expected time for operations requiring inspection and testing services.

1. When tests or inspections cannot be performed after such notice, Contractor shall notify the laboratory.
2. If Contractor does not notify the laboratory before laboratory personnel are scheduled for this work, Contractor shall reimburse the laboratory personnel for time and travel expenses.

1.08 PAYMENT FOR TESTING

- A. Initial Service:
 1. When initial tests indicate non-compliance with the Contract Documents, the costs of initial tests associated with that non-compliance will be deducted by the Owner from the Contract Sum.
- B. Retesting:
 1. When initial tests indicate non-compliance with the Contract Documents, all subsequent retesting occasioned by the non-compliance shall be performed by the same testing agency and the costs thereof will be deducted by the Owner from the Contract Sum.
- C. Contractor's Convenience Testing:
 1. Inspecting and testing performed exclusively for the Contractor's convenience shall be the sole responsibility of the Contractor.

1.09 CODE COMPLIANCE TESTING

- A. Inspections and tests required by codes or ordinances, or by a plan approval authority having jurisdiction over the project site, and which are made by a legally constituted authority, shall be the responsibility of and shall be paid for by the Contractor, unless otherwise provided in the Contract Documents.

PART 2 – PRODUCTS

N/A

PART 3 – EXECUTION

N/A

END OF SECTION

SECTION 4.01

SANITARY SEWER SYSTEM

PART 1 - GENERAL

1.1 REFERENCES

- A. ANSI/ASTM D2321 - Recommended Practice for Underground Installation of Flexible Thermoplastic Sewer Pipe.
- B. ANSI/ASTM D3034 - Type PSM Poly (Vinyl Chloride) (PVC) Sewer Pipe and Fittings.

1.2 SUBMITTALS

- A. Submit shop drawings under provisions of Section 2.04 for system, showing pipe sizes, locations, elevations and slopes for horizontal runs. Include details of underground structures, fittings, connections, and mechanical equipment.
- B. For staking sewer lines submit two copies of each "cut sheet" showing depths of cut from top of offset stake. If a laser beam is used, cut sheet shall also show cut for each 50'-0" station in order to compute depth of cut.

1.3 PROJECT RECORD DOCUMENTS

- A. Submit documents under provisions of Section 2.09.
- B. Record location of pipe runs, connections, cleanouts, and invert elevations.
- C. Identify and describe unexpected variations to subsoil conditions or discovery of uncharted utilities.

1.4 QUALITY ASSURANCE

- A. Installer: A firm specializing and experienced in sanitary sewer system work for not less than 2 years.
- B. Pipe: Pipe shipped to project site shall bear mark of the manufacturer with manufacturer's date of production and pertinent product testing specifications.

PART 2 - PRODUCTS

2.1 DUCTILE IRON GRAVITY PIPE

- A. Ductile Iron Pipe: Class 52, AWWA C150 and AWWA C151; Service type, minimum inside nominal diameter of 8 inches for public mains and 6 inches for service lines.
 - 1. Ductile Iron Pipe Joint Device: ANSI A21.11, rubber gasket joint devices.

- B. Ductile Iron pipe shall be lined with an amine cured novalac epoxy containing at least 20% by volume of ceramic quartz pigment. Any request for substitution must be accompanied by a successful history of lining pipe and fittings for sewer service, a test report verifying the following properties, and a certification of the test results.
 - 1. A permeability rating of 0.00 when test according to Method A of ASTM E96, Procedure A with a test duration of 30 days.
 - 2. The following test must be run on coupons from factory lined ductile iron pipe:
 - a. ASTM B117 Salt Spray (scribed panel) – Results to equal 0.0 undercutting after two year.
 - b. ASTM G95 Cathodic Disbondment 1.5 volts @ 77°F. Results to equal no more than 0.5mm undercutting after 30 days.
 - c. Immersion Testing rated using ASTM D714.
 - i. 20% Sulfuric Acid – No effect after 2 years.
 - ii. 25% Sodium Hydroxide – No effect after 2 years.
 - iii. 160°F Distilled Water – No effect after 2 years.
 - iv. 120°F Tap Water (scribed panel) – 0.0 undercutting after 2 years with no effect.
 - 3. An abrasion resistance of no more than 4 mils loss after one million cycles – European Standard EN 598: 1994 Section 7.8 Abrasion resistance.
 - 4. The lining shall be applied by a competent firm with a successful history of applying linings to the interior of ductile iron pipe and fittings.
 - 5. Prior to abrasive blasting, the entire area to receive the protective compound shall be inspected for oil, grease, etc. Any areas where oil, grease of any substance which can be removed by solvent is present shall be solvent cleaned using the guidelines outlined in DIPRA-1 Solvent Cleaning. After the surface has been made free of grease, oil or other substances, all areas to receive the protective compounds shall be abrasive blasted using compressed air nozzles with sand or grit abrasive media. The entire surface to be lined

- shall be struck with the blast media so that all rust, loose oxides, etc., are removed from the surface. Only slight stains and tightly adhering annealing oxide may be left on the surface. Any area where rust reappears before lining must be reblasted.
6. After surface preparation and within 8 hours of surface preparation, the interior of the pipe shall receive 40 mils nominal dry film thickness of Protecto 401. No lining shall take place when the ambient or substrate temperature is below 40 degrees Fahrenheit. The surface also must be dry and dust free.
 7. Due to the tolerances involved, the gasket area and spigot end up to 6 inches back from the end of the spigot must be coated with 6 mils nominal, 10 mils maximum Protecto Joint Compound. The joint compound shall be applied by brush to ensure coverage. Care should be taken that the joint compound is smooth without excess buildup in the gasket seat or on the spigot ends. Coating of the gasket seat and spigot shall be done after the application of the lining.
 8. The number of coats of lining material applied shall be as recommended by the lining manufacturer. However, in no case shall this material be applied above the dry thickness per coat recommended by the lining manufacturer in printed literature. The maximum or minimum time between coats shall be that time recommended by the lining material manufacturer. No material shall be used for lining which is not indefinitely recoatable with itself without roughening of the surface.
 9. Protecto Joint Compound shall be used for touch-up or repair in accordance with manufacturer's recommendations.
 10. Inspection
 - a. All ductile iron pipe and fittings shall be checked for the thickness using a magnetic film thickness gauge. The thickness testing shall be done using the method outlined in SSPC-PA-2, Film Thickness Rating.
 - b. The interior lining of all pipe barrels and fittings shall be tested for pinholes with a non-destructive 2500 volt test. Any defect found shall be repaired prior to shipment.
 - c. Each pipe joint and fitting shall be marked with the date of application on that date and records maintained by the applicator.
 11. The pipe or fitting manufacturer must supply a certificate attesting to the fact that the applicator met the requirements of this specification, and that the material used was as specified.
 12. Protecto 401 lined pipe and fittings must be handled only from the outside of the pipe and fittings. No forks, chains, straps, hooks, etc. Shall be placed inside the pipe or fittings for lifting, positioning of laying.

- D. For ductile iron pipe, pipe manufacturer is to furnish Engineer a certificate of inspection, sworn to by the factory inspector in the presence of a notary public, stating that pieces of pipe in the shipment were made and tested in accordance with ANSI A21.51 and that they were subjected to and withstood a hydrostatic pressure of 500 psi. Each statement is to give the number of pieces of pipe in shipment, length of each piece of pipe, and identification number of each piece of pipe making up the shipment. In addition, the weight of each individual piece of pipe making up the shipment is to be listed opposite the identification number of each pipe length and attached to the certificate of inspection.

2.2 POLYVINYL CHLORIDE (PVC) GRAVITY PIPE

- A. Plastic Pipe: ANSI/ASTM D3034, Type PSM, Poly (Vinyl Chloride) (PVC) material; SDR 26; minimum inside nominal diameter of 8 inches for public sewer lines and 6 inches for service lines.
 - 1. Pipe Gaskets: Rubber ASTM D1869.
 - 2. Minimum Pipe Stiffness (F/AY) at 5% Deflection: 26 for sizes when tested in accordance with ASTM D 2412.
 - 3. Minimum thickness shall be as follows:

<u>Nominal Size</u>	<u>Minimum Wall Thickness</u>
6	0.255"
8	0.332"
10	0.413"
12	0.490"

2.3 FITTINGS FOR GRAVITY PIPE

- A. Fittings for service line material shall be of the same material as the corresponding main line material. Ductile iron fittings shall be lined per Paragraph 2.1.B of this Section.

2.4 PRESSURE PIPE

- A. Force main pipe less than 4-inch diameter: Plastic Pipe for small diameter sewage force mains, typically associated with the Town of Chapel Hill's grinder sewer system: ANSI/ASTM D2241, Poly Vinyl Chloride (PVC) material; SDR 21;
- B. Force main pipe from 4 inch up to 12-inch diameter: Material shall be DR 25, C900 PVC, green in color.
- C. Force main pipe greater than 12-inch diameter: Material shall be as directed by the Town of Chapel Hill.

- D. Fittings for Pressure Pipe:
 - 1. For PVC Pipe – Fittings shall be manufactured from virgin rigid PVC vinyl compounds with a Cell Class of 12454 as identified in ASTM D1784. Fittings shall conform to ASTM D2466. Pipe and fittings shall be manufactured as a system in the U.S.A and shall conform to NSF Standard 61.
 - 2. For DIP Pipe – Fittings shall meet the requirements of Paragraph 2.1.B above and also meet the requirements of AWWA/ANSI C153 for compact ductile iron fittings.

2.5 PIPE ACCESSORIES

- A. Pipe Connectors: Flexible pipe-to-manhole EPDM gaskets as specified in Section 02607.
- B. For detection purposes, a 10 gauge solid strand copper, green clad tracing wire (shielded) shall be installed with the plastic force main pipe. Connections between wires shall be soldered or connected with wire nut fasteners and wrapped and sealed to be watertight. For access purposes, tracing wire shall be terminated at all valve boxes, combination air valve assemblies, etc.
- C. Magnetic detectable conductor, metallic tape clear plastic covering, imprinted with "CAUTION BURIED SEWER LINE" in large letters shall be installed 18 inches above all sewer pipe (gravity and pressure).
- D. House Line Connection Couplings: Standard manufacturer's product.
 - 1. FERNCO Series 5000 RC
 - 2. Substitutions: Under provisions of Section 01600.
- E. Fittings: ASTM F477; SDR 26; same material as pipe molded or formed to suit pipe size and end design, in required tee, bends, elbows, cleanouts, reducers, traps and other configurations required.
 - 1. Manufacturer: HARCO
 - 2. Substitutions: Under provisions of Section 01600.

2.6 BEDDING MATERIALS

- A. Aggregate Fill: As specified in Section 02225.
- B. Earth Fill: As specified in Section 02225.
- C. Concrete: As specified in Section 03001.
- D. Lean Concrete: As specified in Section 02225.

PART 3 - EXECUTION

3.1 EXAMINATION

- A. Verify that trench cut is ready to receive work and excavations, dimensions, and elevations are as indicated on layout.

3.2 PREPARATION

- A. Hand trim excavations to required elevations. Correct over excavation with bedding material or lean concrete as directed by the Town of Chapel Hill. Minimum 6-inch clearance required between edge of trench and outside diameter of pipe bell.
- B. Remove large stones or other hard matter which could damage pipe or impede consistent backfilling or compaction.

3.3 BEDDING AND BACKFILL

- A. Excavate pipe trench in accordance with Section 02225 for Work of this Section. Hand trim excavation for accurate placement of pipe to elevations indicated.
- B. Provide non-metallic sewer pipe (except house connection lines) with 2'-6" minimum cover in fields, yards, lawns, and other landscaped areas and 4'-0" minimum cover in streets, roads, shoulders and driveways.
 - 1. Where the above minimum cover is not possible either encase pipe in concrete in accordance with Standard Drawings or at the direction of the Town of Chapel Hill. Ductile iron pipe shall be used in this application.
 - a. For concrete encasement, place pipe on 6-inch concrete blocks positioned behind each pipe bell. Join pipe. Bring pipe to established grade by driving wooden wedges between pipe and concrete block.
 - b. Firmly affix pipe in place for true alignment. Backfill pipe trench with concrete to spring line of pipe. Suspend backfilling until concrete has attained its "initial set".
 - c. Backfill remainder of pipe trench with concrete to a point above pipe as shown on Standard Drawings, or as directed by the project Engineer and Town of Chapel Hill. After 24 hours, complete backfill as specified herein.
 - d. Place mastic expansion joints across encasement, 25'-0" o.c.
- C. Unless specifically directed otherwise by the project Engineer or where required to uncover or determine the presence of underground obstructions,

do not open more than 300'-0" of trench ahead of pipe laying. Do not leave more than 200'-0" of open ditch behind pipe laying.

- D. Unless specifically authorized otherwise by the project Engineer, do not excavate trenches wider than 18 inches plus nominal diameter of pipe at level of crown of pipe.
- E. Open trench a minimum of 6" below bottom of pipe at proper line and grade.
- F. Place aggregate fill material at trench bottom, level materials in continuous layer not exceeding 6 inches compacted depth, compact to 95 percent Standard Proctor. Provide aggregate fill 4 inches deep at house connections.
- G. Maintain optimum moisture content of bedding material to attain required compaction density.
- H. Plug open ends of pipe lines at end of each day's work.
- I. Install aggregate fill at sides and over top of PVC pipe to minimum compacted thickness of 12 inches; compacted to 95 percent.
- J. When a sewer line is located in a roadway or shoulder, backfill entire trench with aggregate fill.

3.4 INSTALLATION - PIPE

- A. Install pipe, fittings, and accessories in accordance with ASTM D2321 and manufacturer's instructions. Seal joints watertight. Make house connections with same pipe material as collector sewer lines.
- B. Wipe bell and spigot of each pipe clean before joint is made.
- C. Coat surfaces of bell and gasket with a lubricating material in accordance with pipe manufacturer's instructions.
- D. Align pipe as near as is practical to final grade and alignment with spigot entering bell of last section laid. Apply force to force spigot and gasket home in bell.
- E. Begin laying of gravity sewer pipes in finished trenches, at lowest point so that spigot ends point in direction of flow.
- F. Lay pipe to slope gradients indicated; with maximum variation from true slope of +/-0.05%, 1/16 inch in 10 feet.

1. Slope sewer lines to maintain a minimum velocity of 2 feet per second when flowing full. The minimum slopes allowable are as follows:

a.	<u>Line Size</u>	<u>Minimum Slope</u>
	8 inch	0.40%
	10 inch	0.28%
	12 inch	0.22%

For additional pipe sizes and their associated minimum slopes use TDEC design criteria.

2. Lay service lines to a minimum grade of 1'-0" per 100'-0" (1/8" per foot).
 3. Lay house connection lines as follows:
 - a. 6 inch lines at 1'-0" per 100'-0" minimum.
- G. Seal open ends with a stopper or bulkhead. Mark property line end of house connection on ground by a stake as shown on Standard Drawings.
- H. In general, tapping house connections into manholes will not be permitted unless otherwise approved by the Town of Chapel Hill. Where it is necessary to do so, the invert of house connection shall not be higher than a point 3 inches below top of bench in manhole. Provide a trough in bench to prevent accumulation of solids on bench. If necessary, provide a standard interior drop connection for a house service that is tapped into a manhole.
- I. Refer to Section 3.08 for trenching requirements. Do not displace or damage pipe when compacting.
- J. Refer to Section 4.02 for manhole requirements.
- K. Only one house shall be connected to one service line.
- L. Install trace wire and locate tape in accordance with Paragraphs 2.5.B and 2.5.C of this Section.
- M. Provide concrete foundations under PVC tees and wyes to prevent settlement.

3.5 HOUSE LINE CONNECTIONS - NEW MAIN INSTALLATIONS

- A. 6-inch service line material shall match main line material. Make connection of a 4-inch house service line to the 6-inch service line using an appropriate transition coupling compatible with the specific pipe material(s). Install a cleanout assembly per the Standard Drawings.
- B. Make connections of cast iron pipe and clay pipe with a special adapter.

- C. If the house connection is being tied directly to sewer line, install sewer and service lines in accordance with this Section.
- D. Make connection between house service line and sewer line, if no service line is available, by cutting in a factory tee and reconnecting pipes with PVC knock-on couplings.

3.6 CUSTOMER LINE CONNECTIONS - EXISTING MAIN INSTALLATIONS

- A. If no service line is available from the sewer main, make connection to main using a tapping saddle with tee, cut-in tee with knock on coupling, or Inserta-Tee. Hammer taps are not allowed.
- B. If service line is available from the sewer main, make connection to service line using a PVC compression coupling. No flexible couplings shall be allowed.
- C. Allow inspection by Town of Chapel Hill representative before backfilling.

3.7 ABANDONMENT OF NEW AND EXISTING SERVICES

- A. For new service taps that have not been connected to a house or building, remove the rubber fernco cap and replace with PVC glue on cap at the stub-out location.
- B. For existing sewer services previously connected to a house or building, the service line shall be cut and capped with PVC glue on cap, generally, at the R.O.W. or edge of easement.

3.8 FIELD QUALITY CONTROL

- A. Field inspection and testing of materials will be performed under provisions of Section 2.03.
- B. Request inspection of pipe and ditch prior to and immediately after placing bedding.
- C. Upon completion of the Work, inspect sanitary sewer lines for leaks, defects, or cases of excess deflection. Repair any deficiencies to the satisfaction of the Town of Chapel Hill.
- D. Perform testing of completed pipe lines in accordance with these specifications.
- E. Make tests after completed backfilling.

3.9 VISUAL TESTS

- A. Before backfilling lines, they should be inspected by the Town of Chapel Hill. If acceptable, proceed with backfilling. Remove and correct joints, pipes, or other materials or workmanship found to be defective, without any extra compensation.
- B. During and upon completion of construction, the Town of Chapel Hill will make observations of the Work. Immediately repair leaks and defects found by such observation.
- C. In addition to general cleanup and leakage, use the following standards to determine failure or defects of the Work:
 - 1. Build sewers true to line and planned grade. Confirm In and Out inverts at all manholes to be consistent with approved plans. Note any deviations and notify the Town of Chapel Hill. Replace or re-lay pipe that does not comply with the approved plans unless otherwise permitted by the Town of Chapel Hill.
 - 2. If PVC pipe is used, after complete backfilling, pull or float a ball thru a portion of pipe to test it for deflection. Ball shall be accurately sized to be 95% of pipe diameter of actual pipe used. Contractor will be directed by the project Engineer in his presence and witnessed by the Town of Chapel Hill to perform this test on total pipe length of the project. One hundred percent of the tested Section shall pass this test. Mandrel testing shall not begin until thirty days after backfilling.

3.10 TESTING OF GRAVITY SEWERS

A. TELEVISION INSPECTION

- 1. Upon completion of the construction or earlier if the Town of Chapel Hill deems advisable, the Contractor shall provide for a visual inspection of the sewer by use of remote television camera. Immediately repair all leaks and defects found by such inspection.
- 2. Prior to televising, Contractor shall thoroughly clean the pipelines of debris, grease, roots, sediment or other obstructions that could retard the movement of the television camera.
- 3. Immediately after cleaning, 100% of the line segments shall be visually inspected by means of closed-circuit television to verify cleaning results, the condition of the line and to locate existing service connections. The Contractor shall furnish the mobile television inspection studio, all television equipment and other

necessary types of equipment, and all materials, electricity, labor, technicians, etc., as may be needed to perform the closed circuit television inspection of the new sewers for the purpose of documenting deficiencies and lateral locations prior to acceptance and placement in service of the sewer. A recorded verbal narrative describing pipe conditions and lateral locations shall be placed on the video recording and coincide with the written comments on the videotape. No work is authorized under this Section unless the Town of Chapel Hill's representative is present or has been notified 24 hours prior.

4. Sewer shall be built so as to remain true to line and grade. The inclining grade of the bottom of the sewer after completion shall be such that, after flooding, the flood water drains off so that no remaining puddle of water is deeper than ½ inch on 36 inches internal diameter or small and ¾ inch on pipe larger than 36 inch internal diameter. Any section of pipe that does not comply with the specifications at any time previous to final acceptance of the work shall be replaced or re-laid at the Contractor's expense.
5. The contractor shall be held strictly responsible that all parts of the work bear the load of the backfill. If cracks 0.01 inch develop in the pipe within one (1) year from the date of final acceptance of the work, the Contractor shall be required to replace, at this expense all such cracked pipe. To this end, the Contractor is advised to purchase pipe under a guarantee from the manufacturer guaranteeing proper service of sewer pipe under local conditions established by the drawings, specification and local conditions at the site of the work.
6. Camera Requirements - The camera used for this inspection shall be color. The camera head shall be capable of at least 340 degrees axial rotation and 270 degrees lateral swing. The camera shall operate under a minimum scene illumination of 3 lux with a horizontal resolution of no less than 460 lines. Sufficient lighting shall be provided on the camera so that videotapes will show images that are clear and well illuminated.
7. The internal inspection shall be performed in one section of sewer at a time between adjacent manholes. The inspection shall be performed by pulling the television camera on a skid or by transporting the camera with a mechanical transport device through the section of the sewer along the axis of the pipe. The camera shall travel in the direction of the flow or from the upstream manhole to the downstream manhole unless an obstruction in the pipe requires videotaping upstream. The camera shall not pass through the sewer at a rate greater than ¾ ft/sec. The camera shall stop at each lateral and defect and rotate so that the lateral or defect is seen from a perpendicular field of view. Each lateral and defect shall be extensively filmed.

8. The sewer main shall be clean prior to televising. If the main is new or recently rehabilitated, cleaning may not be necessary. The camera operator shall take necessary precautions to prevent “hanging” the camera in the sewer main. If the camera should get stuck in the main, the contractor will be responsible for removing the camera at his expense and making any above and below ground repairs. The Contractor shall exhaust all other means to retrieve the camera before excavating. A representative of the Town of Chapel Hill must be notified before excavation takes place. The distance measured to defects and lateral shall be referenced to the center of the beginning manhole. Measurements to defects and laterals shall be accurate to within +/-1 foot.

B. Documentation

1. The Contractor shall keep a daily log or record covering the television inspection work and the information acquired there from. This daily log or record shall contain at least the following data:
 - a. Date and Time of Inspection
 - b. Contract Name and Number
 - c. Name of Contractor
 - d. Name of Internal Video Inspection Company (if different from Contractor)
 - e. Name of Street
 - f. Identification Number of Upstream and Downstream Manholes based on Town numbering system.
 - g. Description of the Location
 - h. Direction of the Video
 - i. Size, Length, Depth, and Type of Pipe
 - j. Size, Depth, and Material of Manholes
 - k. Distance, Position on Periphery of Pipe in Clock Orientation, Type, and Description of all Laterals and Defects
 - l. Computer generated diagram of pipe and manholes which graphically provides information in “k” and “l” above.
 - m. An Index of Video System Codes and Abbreviations
2. Two copies of log or record with the diagrams and index, typed and bound, shall be delivered to the Town of Chapel Hill.
3. The purpose of the video recordings shall be to supply a continuous visual and audio record of the inspection using a DVD system. The Contractor shall fill each DVD as much as practical to minimize the number of DVD’s. All sections of runs shall be recorded on one DVD. In no event, shall a segment be divided between two DVD’s. Pipe runs shall be grouped in areas and submitted in sequential order relating to the area designation.

4. Video recordings shall be enclosed in vinyl plastic containers, which shall clearly indicate the date the video was taken, the street and the designated section(s) of sewer line(s) contained on the video, the name of the project, the name of the Contractor and the index number of the video. The index number shall indicate the sequential number of the DVD out of the total number of DVD's for the project, i.e. 2 of 5.
5. Warranty: The Contractor warrants the accuracy and completeness of the DVD for a period of two years. If the Town determines that the video does not meet the requirements as identified herein, the Contractor shall re-video the line segments for which the reporting was faulty. There shall be no discrepancies between the video and the written report.
6. A copy of any software required to view the DVD shall be provided to the Town of Chapel Hill at no additional charge.

3.11 GRAVITY SEWER PRESSURE TESTING

- A. Measurement of sewers subjected to air tests will be horizontal length of test section between manholes as determined by manhole stations, without allowances for service lines connected thereto.
- B. Test sewer line in increments between manholes. Seal line at each end. All lines shall be flushed by other means prior to air testing. The ends of all branches, laterals, tees, wyes and stubs included in the test section shall be plugged or capped to prevent air leakage. All plugs and caps shall be securely braced to prevent blowout. Connect air supply to orifice at one end of line. Air supply line shall contain an on-off valve and a pressure gauge having a range of from 0 to 10 psi. The gauge shall have minimum divisions of 0.10 psi and shall have an accuracy of plus or minus 0.04 psi.
- C. Add air slowly pressurizing pipe line under test to 4 PSIG. Allow line to stabilize between 4 PSIG and 3.5 PSIG for a period of no less than 2 minutes. **DO NOT OVER-PRESSURIZE THE LINES. Do not exceed 9.0 psig.** If necessary, add air to line to maintain pressure above 3.5 PSIG and wait for the pipe equilibrium to be reached. After stabilization period, close valve. When line pressure drops to 3.5 PSIG, commence timing with a stop watch. A minimum of 3.5 psig is required to begin testing. Allow stop watch to run until such time as line pressure drops to 2.5 PSIG, then stop watch.
- D. Compare time lapse with allowable time lapse in Schedule at end of this Section. If time lapse is greater than that specified, section undergoing test shall have passed and test may be discontinued at that time. If time is less than that specified, then line has not passed test and Contractor will be required to prepare line for retest.

- E. Where ground water table is known to be above sewer, raise pressures by an amount equal to ground water pressure (0.433 psi per foot of water). Air pressure test may be made with pipe in a dry or normal condition, but in event section fails to pass test, Contractor will be permitted to repeat test after having soaked pipe to produce moisture saturation. If groundwater is greater than 2 feet above the top of the pipe at the upstream end, low pressure air testing should not be used.
- F. Avoid over pressuring sewer and avoid blowing out test plugs. Do not enter an adjacent manhole while a section of sewer is under test. Plug and strap down service lines to prevent blowouts.
- G. Minimum time for a 1.0-psig Low Pressure Air Test Time for Size and Length of Pipe for $Q=0.0015$ in seconds:

Table 1

Pipe Diameter (inches)	Min. Test Time (min:sec)	Length for Min. Time (ft)	Time for Longer Length (sec)	Minimum Test Time (min:sec) for Specific Length (L)						
				100 ft	150 ft	200 ft	250 ft	300 ft	350 ft	400 ft
4	3:46	597	0.380L	3:46	3:46	3:46	3:46	3:46	3:46	3:46
6	5:40	398	0.854L	5:40	5:40	5:40	5:40	5:40	5:40	5:42
8	7:34	298	1.520L	7:34	7:34	7:34	7:34	7:36	8:52	10:08
10	9:26	239	2.374L	9:26	9:26	9:26	9:53	11:52	13:51	15:49
12	11:20	199	3.418L	11:20	11:20	11:24	14:15	17:05	19:56	22:47
15	14:10	159	5.342L	14:10	14:10	17:48	22:15	26:42	31:09	35:36
18	17:00	133	7.692L	17:00	19:13	25:38	32:03	38:27	44:52	51:16
21	19:50	114	10.470L	19:50	26:10	34:54	43:37	52:21	61:00	69:48
24	22:40	99	13.674L	22:47	34:11	45:34	56:58	68:22	79:46	91:10

It is not necessary to hold the test for the entire period of time in the Table 1 when it is evident that the rate of air loss is zero or less than the allowable, and is authorized by the Town of Chapel Hill.

- H. If lateral or service lines are included in the test, their length may be ignored for computed required test time if the test time requirements are met. The maximum permissible air loss shall not exceed $625Q$ where $Q=0.0015CFM/SF$.
- I. Contact the Town of Chapel Hill for air test times on pipe diameters not shown above.

3.12 FORCE MAIN PRESSURE TESTING

- A. All force mains shall be tested to a test pressure of 120 psi for a duration of two (2) hours. Backfilling shall occur on the force main to the extent

that it will remain in place without movement. No leakage will be permitted on force main testing and success of testing will be on a “Pass or Fail” score. All force main testing shall be performed with potable water or with groundwater. No testing shall occur with live sewage. Maximum length of a force main segment to be tested shall be 2000 LF. For force mains longer than 2000 LF, testing shall occur between valve segments or in a manner approved by the Town of Chapel Hill.

3.13 REPAIRS AND CLEANUP

- A. Regardless of the outcome of any tests, repair any noticeable leak.
- B. After completing each section of the sewer line, remove all debris, construction materials, and equipment from the site of the work, grade and smooth over the surface on both sides of the line, and leave the entire area in a clean, neat, and serviceable condition.

END OF SECTION

SECTION 4.02

MANHOLES, WETWELLS AND MANHOLE COVERS

PART 1 - GENERAL

1.1 REFERENCES

- A. ASTM A48 - Gray Iron Castings.
- B. ASTM C478 - Precast Reinforced Concrete Manhole Sections.
- C. ASTM C923 - Resilient Connectors Between Reinforced Concrete Manhole Structures and pipes.

1.2 SUBMITTALS

- A. Submit under provisions of Section 2.04.
- B. Shop Drawings: Indicate manhole locations, invert elevations, sizes and elevations of penetrations.
- C. Product Data: Provide manhole covers, component construction, features, configuration, and dimensions.

1.3 QUALIFICATIONS

- A. Manufacturer: Company specializing in manufacturing products specified in this section with minimum three years documented experience.

PART 2 - PRODUCTS

2.1 MATERIALS

- A. Manhole Sections: Reinforced precast concrete in accordance with ASTM C478. Reinforced cast-in-place concrete as specified in Section 3.12 will be allowed on a case by case basis with Town of Chapel Hill approval.

2.2 COMPONENTS

- A. Cover and Frame: ASTM A48, Class 30B lid molded with the words, "SANITARY SEWER".
 - 1. Traffic Type: "Number 1150" John Bouchard; 2111Z2/A East Jordan Iron Works, or approved equivalent.

2. Non-Traffic Type: "Number 1155," John Bouchard; 2266Z East Jordan Iron Works, or approved equivalent.
 3. Watertight Type: "Number 1150 or 1155 with bolts and gasket," John Bouchard; 1045ZPT 1040 East Jordan Iron Works, or approved equivalent.
 4. Shallow Type: "Number 1312", John Bouchard or approved equivalent.
 5. Shallow Watertight Type: "Number 1312 with bolts and T-gasket", John Bouchard or approved equivalent.
 6. Composite Type: GMI Composites, Model 2600 or approved equivalent.
 7. Rotating Manhole Cover: For use on manholes with top of casting greater than 2-feet above existing grade: 104050R01 East Jordan Iron Works
- B. Manhole Steps: Either of the following:
1. Formed aluminum rungs; 3/4 inch diameter. Formed integral with manhole sections.
 - a. "Part 12653B," Alcoa
 - b. "PSI-45," M. A. Industries
 2. ASTM C478; injection molded, copolymer polypropylene plastic covered, Number 4, Grade 60, rebar; 5-3/4 inches projection, 12 inches overall width, 9-1/8 inches overall depth; serrated tread; 1500 pounds pullout strength.
 - a. Model "PS1-PF," M. A. Industries, Inc., Peachtree City, GA.
- C. Base Pad: Either precast concrete type or cast-in-place concrete with reinforcement of type specified in Section 03001. Top of poured base shall be level.
- D. Manhole Inverts: Form from concrete as shown on Standard Drawings. Form inverts for a "straight-thru" manhole by laying pipe straight through manhole, pouring concrete invert, and then breaking out top half of pipe. Construct curved inverts of concrete as shown and form a smooth, even half-pipe section as shown. Inverts formed by precast manufacturer are also acceptable.
- E. Pipe Connectors: Flexible pipe-to-manhole EPDM gaskets in accordance with ASTM C923; with non-magnetic 304 stainless steel wedge type expander and pipe clamp; tested without leakage to the following:
1. Head pressure of more than 10 psi for 10 minutes per ASTM C923-7.1; Deflection of over 7 degrees in any direction per ASTM C923-7.2.2; Load of over 150 pounds per inch pipe diameter per ASTM C923-7.2.3.

2. "Kor-N-Seal", Type I or Type II, Toggle Style specifically suited for wastewater applications as manufactured by Trelleborg.
- F. Joint Sealant: One strip of flexible plastic sealant for joints in pre-cast manhole sections shall be installed on the tongue and groove sections of the precast manholes to provide permanent flexible watertight joints which shall remain workable over wide temperature ranges and shall not shrink, harden or oxidize upon aging. Two (2) strips of sealant shall be used on wet well joints. Material shall be butyl resin sealant ConSeal CS-102 or CS-202 as manufactured by Concrete Sealants, Inc. of New Carlisle, Ohio, RUB'R-NEK L-T-M manufactured by K.T. Snyder Company, or other approved equal.
 - G. Exterior Joint Wrap: Joint wrap shall be installed at all joints between riser sections in accordance with ASTM C909. Joint wrap shall be 6-inch minimum width, EZ-WRAP as manufactured by Press-Seal Gasket Corporation, or other approved equal.
 - H. Grade Adjustment Ring: Reinforced concrete adjustment rings shall be allowed up to 12 inches in height. Adjustment casting by the use of adjustment rings in excess of 12 inches in height shall not be permitted. No grade adjustment rings shall be utilized where top of pre-cast section is scheduled to remain above the existing grade.

2.3 CONFIGURATION

- A. Shaft Construction: Eccentric cone top section; lipped male/female dry joints; sleeve to receive conduit sections. For wetwells and shallow-type manholes, precast flattop manhole sections are required with appropriate sized openings.
- B. Shape: Cylindrical.
- C. Clear Inside Dimensions: Manholes shall be 48 inch diameter, minimum, for depths up to 12 feet. For manholes greater than 12 feet and up to 18 feet in depth, diameter shall be 60 inch, minimum. For manholes greater than 18 feet in depth, utilize 72 inch base section (minimum 6 feet high) with transition section to 48 inch diameter risers and cone.
- D. Design Depth: As indicated.
- E. Clear Lid Opening: 26 inches diameter minimum opening required for manholes. Opening for wetwells is as required by plans.
- F. Pipe and Conduit Entry: Provide openings as required with resilient pipe connectors.

- G. Steps: 12 inches wide, 15 inches on center vertically, set into manhole wall. Steps are not permitted inside wetwells.

2.4 FABRICATION

- A. Manhole sections showing evidence of cracking, crazing, honeycombing, crumbling, or excessive roughness will not be accepted. Manhole sections with improper cut-outs for pipes will not be acceptable. Poorly finished or ill-fitting manhole sections will be rejected.
- B. Castings shall be first quality, free from blow holes, shrinkage, distortion, or other defects.
- C. Manholes shall be smooth and well-cleaned, and shall be coated with Xypex Admix C-1000. Using normal practices to ensure formation of homogeneous mixture. **PRECAST BATCH PLANT – PAN TYPE MIXER:** Add Xypex Admix to the rock and sand, then mix thoroughly for 2-3 minutes before adding the cement and water. The total concrete mass should be blended using standard practices. A red colorant shall be added to verify the Xypex Admix was added to the concrete.

PART 3 - EXECUTION

3.1 EXAMINATION

- A. Verify items provided by other sections of Work are properly sized and located. Verify that built-in items are in proper location, and ready for roughing into Work. Verify excavation for manholes is correct.

3.2 PREPARATION

- A. Coordinate placement of inlet and outlet pipe required by other sections or plans.

3.3 PLACING MANHOLE SECTIONS

- A. Place base pad, trowel top surface level. At manholes 14'-0" and over in depth, provide an 8 inch lean concrete footing as shown on Standard Drawings.
- B. Place prefabricated manhole sections plumb and level, trim to correct elevations, anchor to base pad.
- C. Form and place cast-in-place concrete manhole cylinder plumb and level, to corrections dimensions and elevations. As work progresses, build-in fabricated metal items.

- D. Cut and fit for conduit and sleeves.
- E. Grout base of shaft sections to achieve slope to exit piping. Trowel smooth. Contour as required.
- F. Form manhole inverts from concrete as shown on Standard Drawings. Slope bench uniformly to trough. Slope inverts at same slope as sewer either entering or leaving manhole. Minimum elevation difference between inlet pipe(s) and outlet pipe is 0.2 feet.
- G. Install drop inlet assemblies at manholes in which difference of flow lines is more than 24 inches. For differences of flow lines less than 24 inches, slope manhole invert to connect grades.
 - 1. Drop Inlet Assemblies: Stacks placed adjacent to manhole supported by poured concrete, as shown on Standard Drawings.
- H. Set cover frames and covers level without tipping, to correct elevations.
- I. Set top of manhole covers level with surrounding ground or as otherwise directed by the Town of Chapel Hill. Grade so that no water will flow into manhole cover or stand on cover.
- J. Trim and remove excess joint material on inside walls.
- K. Manhole lids shall set flat in frame without rocking. Rocking covers shall be corrected by use of a grinder, or shall be replaced.
- L. Precast manhole adjustment rings may be used as outlined in Paragraph 2.2.H for final grade adjustment. No brick adjustment of casting will be allowed.
- M. Vacuum Testing of New Manholes:
 - 1. This test is only applicable to pre-cast concrete manholes.
 - 2. All lifting holes and exterior joints shall be filled and pointed with an approved non-shrink mortar.
 - 3. Each manhole shall be vacuum tested immediately after installation or rehabilitation and prior to backfilling. No standing water shall be allowed in the manhole excavation which may affect the accuracy of the test.
 - 4. All pipes and other openings into the manhole shall be suitably plugged in such a manner as to prevent displacement of the plugs while the vacuum is drawn.
 - 5. Installation and operation of the vacuum equipment and indicating devices shall be in accordance with equipment specifications and instructions provided by the manufacturer.

6. The test head shall be placed to include the manhole casting (frame).
7. A vacuum of 10 inches of mercury shall be drawn. The time for the vacuum to drop to 9 inches shall be recorded.
8. Acceptance for four (4) feet diameter manholes shall be defined as when the time to drop to 9 inches of mercury conforms to the table below. Contractor shall keep a log of all tests which shall be submitted to the Engineer for approval.

<u>Manhole Depth</u>	<u>Time to Drop One (1) Inch</u>
10 feet or less	60 seconds
10.1 feet to 15 feet	75 seconds
15.1 feet to 25 feet	90 seconds

9. For manholes five (5) feet in diameter, add an additional 15 seconds. For manholes six (6) feet in diameter (or having a six (6) feet diameter base), add an additional 30 seconds.
 10. If the manhole fails the test, necessary repairs shall be made and the vacuum test repeated until the manhole passes the test.
 11. If the manhole joint mastic or gasket is displaced during the vacuum test, the manhole shall be disassembled, the seal replaced, and the manhole re-tested.
 12. No additional payment will be made for testing and cost shall be merged into cost of manholes.
- N. Where a sewage force main enters a manhole, the cover and frame on the three downstream manholes (new or existing), including the one containing the force main connection, shall be GMI Composite Manhole Frame and Cover with minimum 26" clear opening and 1/4" turn paddle locks or approved equivalent. Manholes shall also be coated with spray applied epoxy resin (Level Yellow) as per Section 02765 and subsequently tested in accordance with Paragraph 3.3.M of this Section.
- O. Coordinate with other sections of work to provide correct size, shape, and location.

END OF SECTION

SECTION 04.03

SANITARY SEWER VALVES

PART 1 – GENERAL

1.1 SECTION INCLUDES

- A. Installation of valves as specified below.
- B. Refer to other sections for work related to that specified under this heading.

PART 2 – PRODUCTS

2.1 PLUG VALVES

- A. All plug valves shall be eccentric, multi-directional plug valves with 100% full port unless otherwise specified.
- B. Valves shall be of the non-lubricated eccentric type with resilient faced plugs and shall be furnished with mechanical joint end connections.
- C. Valve bodies shall be of ASTM A126 Class B cast iron. Bodies in 4" and larger valves shall be furnished with a 1/8" welded overlay seat of not less than 90% pure nickel. Seat area shall be raised, with raised surface completely covered with weld to insure that the plug face contacts only nickel. Screwed-in seats shall not be acceptable.
- D. Plugs shall be of ASTM A126 Class B cast iron. The plug shall have a cylindrical seating surface eccentrically offset from the center of the plug shaft. The interference between the plug face and body seat, with the plug in the closed position, shall be externally adjustable in the field with the valve in the line under pressure. Plug shall be resilient faced with neoprene or hycar, suitable for use with sewage.
- E. Valves shall have sleeve type metal bearings and shall be of sintered, oil impregnated permanently lubricated Type 316 ASTM A743 Grade CF-8M or AISI Type 317L stainless steel. Non-metallic bearings shall not be acceptable.
- F. Valve shaft seals shall be of the multiple V-ring type and shall be externally adjustable and repackable without removing the bonnet or actuator from the valve under pressure. Valves utilizing O-ring seals or non-adjustable packing shall not be acceptable.
- G. Valve pressure ratings shall be 175 psi through 12" and 150 psi for 14" through 72". Each valve shall be given a hydrostatic and seat test with test results being certified when required by the specifications.

- H. Non-buried manual valves shall have handwheel gear actuators. Buried valves shall be provided with tee wrenches and extension stems. Valves larger than 6” may be equipped with gear actuators, depending on the Town of Chapel Hill’s recommendations. All manual actuators shall be rated for the full pressure rating of the valve. All gearing shall be enclosed in a semi-steel housing and be suitable for running in a lubricant with seals provided on all shafts to prevent entry of dirt and water into the actuator. The actuator shaft and the quadrant shall be supported on permanently lubricated bronze bearings. Actuators shall clearly indicate valve position and an adjustable stop shall be provided to set closing torque and to provide seat adjustment to compensate for change in pressure differential or flow direction change. All exposed nuts, bolts and washers shall be zinc plated.
- I. Valves and gear actuators for buried or submerged service shall have seals on all shafts and gaskets on the valve and actuator covers to prevent the entry of water. Actuator mounting brackets for buried or submerged service shall be totally enclosed and shall have gasket seals. All exposed nuts, bolts, springs and washer shall be stainless steel.
- J. All valves shall be as manufactured by DeZURIK Model PEF.

2.2 COMBINATION AIR VALVES

- A. All force mains shall have combination air valves installed as they are indicated on the plans.
- B. The body of the valves shall be conical shaped to maintain maximum air gap with the spring loaded float and seal plug connection combining to ensure no contact between the sewage and the seal.
- C. The valve shall have a double float design with the upper float being enclosed in the upper section of the valve and shall be made of polypropylene.
- D. The lower float shall be in the main body of the valve and shall be constructed of 316 stainless steel.
- E. The body, cover flange, and lower flange shall be constructed of 316 stainless steel and shall have a funnel shaped lower body to automatically drain sewage back into the system.
- F. All internal metal parts are to be made from corrosion resistant 316 stainless steel with all operating parts in the upper section to be non-metallic plastic materials.
- G. The hinge for operation for the opening and closing of the seal on the orifice shall be made of EPDM rubber.

- B. The valve body shall be a one piece cast iron or cast steel casting with integral flanges. The flanges shall be faced and drilled in accordance with ANSI B16.1 Class 125.
- C. The hinge shaft shall be located completely above the waterway and shall be constructed of stainless steel with the disc arm and counterweight arm keyed there on. The hinge shaft shall be one piece and shall extend through both sides of the valve body.
- D. The body seat shall be bronze or stainless steel, and the disc shall be cast iron conforming to ASTM A126 Class B. The seat ring shall be a resilient field replaceable ring that can be replaced without the use of special tools.
- E. A lever and adjustable weight shall be provided to initiate closure.
- F. The valve shall be a Golden Anderson Model 250, or APCO Series S-6000.

PART 3 – EXECUTION

3.1 INSTALLATION

- A. Valves shall be installed per manufacturer's recommendations.
- B. Buried valves shall include mechanical joint ends. All valves for aboveground or vault installation shall include flanged ends.
- C. Buried plug valves shall be installed with a 2-inch operating nut accessible from ground level via a cast iron valve box. Flanged plug valves shall be installed with removable, operating lever or handwheel.
- D. Valves shall be plumbed for level installation so as not to place end connection in a bind.
- E. Valves installed outside paved areas shall include a concrete collar around the valve lid at ground surface.
- F. Clean out assemblies shall be installed with a cast iron clean out box over the top of the assembly. Box shall be flush with the finished ground surface. Top of clean out assembly shall be at least 3-inches below the inside surface of the box lid.
- G. All check valves shall be mounted in a horizontal position in a valve vault. No check valves shall be installed in the wet well.
- H. Combination air valves shall be installed in a 4-foot diameter precast concrete manhole with vented cover. Valves shall be located at high points or as directed by the Town of Chapel Hill. Additional force main depth may be required to

allow for height of valve body inside the manhole. Manhole cover shall be flush with existing grade. Valve body shall be adequately supported and braced inside the manhole and not solely dependent upon support by the pipe nipple. All pipe nipples shall be bronze. A cut-off valve with handwheel or lever shall be included to isolate the air valve from the force main. Combination air valves shall be mounted with a double strap, stainless steel tapping saddle manufactured by Ford (FS323 for up to 2-inch tap size) with bronze isolation valve equipped with handwheel. No galvanized piping shall be used.

END OF SECTION

SECTION 4.04

CURED-IN-PLACE PIPE LINING

PART 1 - GENERAL

1.01 DESCRIPTION

- A. This Section includes furnishing all labor, materials, equipment, and incidentals required to install and test the cured-in-place pipe (CIPP) lining and appurtenances complete..
- B. The Contractor shall remove all pipeline obstructions and protruding service connections as required to complete the CIPP rehabilitation. Removal of all pipeline obstructions and protruding service connections greater than ½-inch for host pipe diameters smaller than 18-inch and greater than ¾-inch for larger host pipe diameters required for sewer rehabilitation using cured-in-place pipe lining shall be completed prior to the pre-rehabilitation CCTV inspection.
- C. Neither the CIPP system, nor its installation shall cause adverse effects to any Town of Chapel Hill processes or facilities. Product use shall not result in forming or producing any detrimental compounds or by-products in the wastewater system. The Contractor shall notify the Town of Chapel Hill and identify any by-products produced due to the installation operations and shall test and monitor the levels and comply with any and all local waste discharge requirements.
- D. The Contractor shall cleanup, restore existing surface conditions and structures and repair any CIPP system determined to be defective. The Contractor shall conduct installation operations and schedule cleanup in a manner to cause the least possible obstruction and inconvenience to traffic, pedestrians, businesses, and property owners or tenants.

1.02 SUBMITTALS

- A. Submit product data, design calculations, installation details, and shop drawings to the Town of Chapel Hill in accordance with Section 2.04. The Contractor shall provide this information without delay or claim to any confidentiality. Submittals shall include the following:
 - 1. CIPP lining supplier's name and a materials list
 - 2. CIPP lining schedules including field-verified lengths and diameters for all CIPP linings and appurtenances required.
 - 3. Shop drawings and product data to demonstrate compliance with these specifications and identify construction materials including resins, catalysts, felt, etc., felt manufacturer and facility location, wet-out facility location, etc.

4. Manufacturers' shipping, storage, and handling recommendations for all CIPP system components
5. MSDS sheets for all materials to be furnished for the project
6. Detailed installation procedures including CIPP lining production schedule, acceptable inversion heads and pressures, inversion procedures, curing and cool-down procedures and temperatures, and times for each process stage
7. Prior to each CIPP lining shipment, certified test reports showing the CIPP lining for this Contract was manufactured and tested in accordance with all ASTM Standards specified and referenced herein.
8. A detailed public notification plan shall be prepared and submitted including detailed staged notification to residences affected by the CIPP installation.
9. A complete description for the proposed wet-out procedure for the proposed technology. Wet-outs "over-the-hole" for large CIPP diameters/lengths shall be identified for the segment(s) and include full details of the procedure including environmental conditions control, resin temperature control, quality assurance procedures and etc.
10. Wet-out forms with detailed information including, but not limited to resin volumes and/or weights, CIPP liner length, roller gap settings, start times, finish times, gel times, resin injection locations, and any other pertinent data documenting the wet-out for each CIPP liner section manufactured.
11. Design data and specification data sheets listing all parameters used in the CIPP liner design and thickness calculations based on ASTM F1216. All calculations shall be prepared under and stamped by a Tennessee registered professional engineer.
12. A list with all service laterals abandoned or reconnected as part of the work as further defined herein.
13. Manufacturer's recommended cure method for each CIPP liner diameter and thickness to be installed including detailed curing procedures describing the curing medium and the application method.
14. CIPP lining curing reports documenting the liner installation for all sewer segments. The CIPP lining reports shall document all lining installation details including manhole numbers, street names/sewer location, project number, date, time, temperature, curing temperature, curing time, CIPP liner thickness, etc. A sample report shall be submitted to the Town of Chapel Hill for approval prior to installing any CIPP lining.
15. Pre- and post-rehabilitation CCTV inspection data.

16. Ten reports from projects within the past 2 years from independent testing laboratory for liner materials analysis showing the elasticity modulus as determined by appropriate ASTM standard and flexural stress as determined by appropriate ASTM standard. The lining must be the same resin system and felt tube materials as proposed for this project.
 17. Installed liner(s) samples for testing to be performed by an ASTM-certified independent testing laboratory, as described further herein
 18. Data on the maximum allowable stresses and elongation of the tube during installation and the means the Contractor will use to monitor stress and elongation
 19. A detailed summary about the proposed quality controls to be performed by the Contractor including:
 - a. Proposed procedures for quality control
 - b. Product sampling and testing method and frequency for product sampling and testing in raw material form and cured product form
 - c. Inspection forms and guidelines for quality control inspections
- B. Submit the name and experience for lead personnel including verifiable references, as described in the Qualifications subsection below.

1.03 REFERENCE STANDARDS

- A. American Society for Testing and Materials (ASTM)
1. ASTM D543 – Standard and Practice for Evaluating the Resistance of Plastics to Chemical Reagents
 2. ASTM D638 – Standard Test Method for Tensile Properties of Plastics
 3. ASTM D790 – Standard Test Method for Flexural Properties of Unreinforced and Reinforced Plastics and Electrical Insulating Materials
 4. ASTM D792 – Standard Test Methods for Density and Specific Gravity of Plastics by Displacement
 5. ASTM D2412 – Standard Test Method for Determination of External Loading Characteristics of Plastic Pipe by Parallel-Plate Loading
 6. ASTM F1216 – Standard Practice for Rehabilitation of Existing Pipelines and Conduits by the Inversion and Curing of a Resin-Impregnated Tube
 7. ASTM F1743 – Standard Practice for Rehabilitation of Existing Pipelines and Conduits by Pulled-in-Place Installation of Cured-in-Place Thermosetting Resin Pipe (CIPP)

8. ASTM D638 – Standard Test Method for Tensile Properties of Plastics
 9. ASTM D5813 – Standard Specification for Cured-in-Place Thermosetting Resin Sewer Piping Systems
 10. ASTM D2990 – Standard Test Methods for Tensile, Compressive, and Flexural Creep and Creep-Rupture of Plastics
- B. National Association of Sewer Service Companies (NASSCO)
1. Recommended Specifications for Sewer Collection System Rehabilitation
- C. Where reference is made to one of the above standards, the revision in effect at the time of bid opening shall apply.

1.04 EXPERIENCE AND CERTIFICATIONS

- A. The Contractor performing the CIPP lining work shall be experienced and equipped to complete this work expeditiously and in a satisfactory manner and shall be certified and/or licensed as an installer by the CIPP lining manufacturer.
- B. The lead personnel including the supervisor, the foreman, and the lead crew personnel for the CCTV inspection, factory and “over-the-hole” resin wet-out, the CIPP lining installation, lining curing and the robotic service reconnections each must have a 3-year and/or 250,00 feet minimum total continuous experience with the CIPP technology proposed for this Contract and must have demonstrated competency and experience to perform the scope of work contained in this Contract. Personnel replaced by Contractor during the execution of the work shall have similar verifiable experience as personnel originally submitted for project.

1.05 GUARANTEE

- A. All placed CIPP linings shall be guaranteed by the Contractor and manufacturer for a 3-year period from the final acceptance date. During this period, the Contractor shall remove and replace any and all serious defects discovered in the CIPP lining, as determined by the Town of Chapel Hill, which may materially affect the pipe’s integrity, strength, function, and/or operation in a satisfactory manner to the Town of Chapel Hill at no cost to Town of Chapel Hill. Defects replaced during this 3-year period shall be fully warranted by Contractor and manufacturer for a period of two years from date the defect was repaired.
- B. CIPP tube manufacturer shall warrant the tube and resin materials to be free from any defects for a 10-year minimum from the manufacture date.

1.06 QUALITY ASSURANCE

- A. All CIPP linings shall be from a single manufacturer. The suppliers shall be responsible for providing all test requirements specified herein as applicable. In addition, all CIPP linings to be installed under this Contract may be inspected at the plant for compliance with these specifications by an independent testing

laboratory provided by the Town of Chapel Hill. The Contractor shall require the manufacturer's cooperation with these inspections.

- B. The Town of Chapel Hill may inspect CIPP lining after delivery. The CIPP lining shall be subject to rejection at any time if it fails to meet any requirements specified, even though sample CIPP lining may have been accepted as satisfactory at the manufacturer. CIPP lining rejected after delivery shall be marked for identification and removed from the job site.
- C. In the event that an installation is rejected based on review of the post-rehabilitation CCTV inspection, the Contractor shall repair the sewer segment to the satisfaction of Metro at no additional cost to the Town of Chapel Hill.

1.07 DELIVERY, STORAGE, AND HANDLING

- A. Care shall be taken in shipping, handling, and laying to avoid damaging the CIPP liner. Any CIPP liner damaged in shipment shall be replaced as directed by the Town of Chapel Hill.
- B. Any CIPP lining showing a split or tear or which has received a blow that may have caused damage, even though no such damage can be seen, shall be marked as rejected and removed at once from the work.
- C. While stored, CIPP shall be adequately supported and protected in a manner as recommended by manufacturer.
- D. The CIPP lining shall be maintained at a proper temperature in refrigerated facilities at all times prior to installation to prevent premature curing. The CIPP lining shall be protected from UV light. Any CIPP lining showing evidence of premature curing shall be rejected for use and immediately removed from the site.

1.08 WATER

- A. Water for all construction operations shall be available from identified City fire hydrants at normal commercial rates.
- B. Water usage shall be in accordance with Town backflow and metering policies.

1.09 SEWER CHECK VALVES

- A. If an existing sewer service includes a check valve, then that check valve should remain in place or be replaced with a new check valve during construction.
- B. Removal of an existing check valve shall only occur for the hours of explicit construction for service lateral lining or replacement.
- C. Notify the Town of Chapel Hill immediately of the presence of a service line check valve and maintain the sewage backup prevention aspect of the valve.

PART 2 - PRODUCTS

2.01 CIPP FELT LINER AND RESIN

- A. CIPP lining shall be Inliner Technologies by Layne Inliner, Inc.; Insituform by Insituform Technologies, Inc.; MooreLiner by Moore Construction Co.; SAK Liner by SAK Construction; CIPP Corporation liner by American Infrastructures Technologies; Inverta A Pipe liner by Inland Pipe Rehabilitation (IPR Southeast); or pre-bid approved equal.
- B. The CIPP liner shall have tubing material with one or more layers of a flexible non-woven polyester felt with or without additives such as woven fiberglass or other fibers and shall meet ASTM F1216, ASTM F1743, ASTM D5813, and ASTM D2990 requirements. The CIPP liner's felt content shall be determined by the Contractor, but shall not exceed 15 percent of the total impregnated liner volume. The fabric tube shall be able to absorb and carry resins, be constructed to withstand installation pressures and curing temperatures, and have sufficient strength to bridge missing pipe segments and stretch to fit irregular pipe sections.
- C. The CIPP liner tube may be single or multiple layer construction with any layer not less than 1.5 mm thick. The wet-out fabric tube shall have a uniform thickness and excess resin distribution which, when compressed at installation pressures, will meet or exceed the design thickness after cure.
- D. The tube's outside layer prior to being inverted shall be coated with an impermeable material compatible with the resin and fabric.
- E. The manufactured tube's exterior shall have distance markings along its length at regular intervals not to exceed 5 feet. Use these marks as a gauge to measure elongation during insertion. Should a reach's overall elongation exceed 5 percent, the liner tube shall be rejected and replaced.
- F. The tube shall be homogenous across the entire wall thickness, containing no intermediate or encapsulated layers. No material shall be included in the tube that may cause delamination in the cured CIPP. No dry or unsaturated layers shall be evident upon visual inspection as evident by color contrast between felt fabric and activated resin containing a colorant.
- G. Seams in the tube shall be stronger than the non-seamed felt material and shall meet the requirements of ASTM D5813.
- H. The CIPP's interior wall color after installation shall be a relatively light reflective color so a clear detailed examination with CCTV equipment may be made. Hue of the color shall be dark enough to distinguish a contrast between fully resin saturated felt fabric and dry or resin lean areas.
- I. Resin: Shall be a corrosion resistant polyester or vinyl ester resin and catalyst system or epoxy and hardener system that, when properly cured within the tube composite, meets the requirements of ASTM F 1216, ASTM F 1743 or ASTM F 2019, the physical properties herein, and those, which are to be utilized in the

design of CIPP for this project. Resin shall produce CIPP which will comply with or exceed structural and chemical resistance requirements of this specification. Liner material and resin shall be completely compatible. Generally, resin shall not contain fillers, except those required for viscosity control or fire retardance or increase strength, and with applications for which inert fillers would facilitate better heat transfer and retention during installation. Liner contractor may add up to 5 percent by mass, a thixotropic agent for viscosity control, which will not interfere with visual inspection.

- J. The felt tubing shall be vacuum impregnated with a thermosetting polyester resin and catalyst, vinyl ester resin and catalyst, or epoxy resin, inhibitors and hardener.
- K. The resins may contain pigments, dyes, or colorants which shall not interfere with visually inspecting cured lining. The resin quantity used for tube impregnation shall be sufficient to fill the volume of air voids in the tube with additional allowances for polymerization shrinkage and the resin loss through cracks and irregularities in the original pipe wall. Use a serial vacuum impregnation process (or equal) to provide maximum resin impregnation throughout the tube.
- L. The Contractor shall identify the wet-out facility where all CIPP linings under this Contract will be manufactured. All CIPP linings shall be manufactured from this designated wet-out facility throughout the entire Contract, unless specifically approved otherwise in writing by the Town of Chapel Hill. Multiple wet-out facilities shall not be allowed except for identified and approved "over-the-hole" on-site wet-out facilities for large diameter CIPP.
- M. The Town of Chapel Hill or its representatives may inspect the CIPP lining during manufacturing and wet-out. The City and its representatives must be given an opportunity to witness the manufacturing for all CIPP linings for this project. If the City decides to inspect the CIPP lining manufacturing, the Contractor shall provide full access to witness the wet-out process and any and all information related to the manufacturing as requested without delay and without claims about confidentiality or product privacy. The City is responsible for costs associated with witnessing the CIPP lining manufacturing.
- N. Applying resin to the felt tubing (wet-out) shall be conducted under factory or controlled on-site conditions using vacuum impregnation, and the materials shall be fully protected against UV light, excessive heat, and contamination at all times.
- O. Liners that are impregnated at the factory and transported to the project site in refrigerated trucks shall be installed as soon as possible and no more than ten (10) days after the date of impregnation at the factory.
- P. When cured, the CIPP lining shall form a continuous, hard, impermeable lining which is chemically resistant to any chemicals normally found in domestic sewage per Table x2.1 in ASTM F1216. The CIPP lining shall be chemically resistant to trace amounts of gasoline and other oil products commonly found in municipal sewerage and soils adjacent to the sewer pipe to be lined. The CIPP lining shall provide the maximum available abrasion resistance.

- Q. The Contractor shall measure the existing pipelines in the field prior to ordering lining. The CIPP lining's length shall be as deemed necessary by the Contractor to effectively carry out inserting and sealing the CIPP lining at the outlet and inlet manholes.
1. The CIPP lining tube shall be manufactured or fabricated to a size that will tightly fit the internal circumference of the sewer being rehabilitated after being installed and cured.
 2. The CIPP lining shall be able to fit into irregularly shaped pipe sections and through bends (up to 45 degrees) and dips within the pipeline.
 3. Allowance for longitudinal and circumferential expansion shall be taken into account when sizing and installing the CIPP lining.
 4. The tube shall be properly sized to the existing pipe's diameter and the length to be rehabilitated and be able to stretch to fit irregular pipe sections and negotiate bends.
 5. Contractor shall verify lengths in field prior to ordering and prior to impregnation of tube with resin, to ensure that tube will have sufficient length to extend entire length of the run, which is defined as the length of the existing host pipe measured from the interior walls of the manholes, and/or from the ends of the pipe when/if the pipe extends into the manholes. Contractor shall also measure inside diameter and circumference of existing pipelines at face of each manhole in field prior to ordering liner so that liner can be installed in a tight-fitted condition with little or no wrinkling.
- R. The Contractor shall verify the proposed CIPP lining thicknesses and submit the associated calculations. The CIPP lining for 8-inch through 10-inch host pipe shall be designed in accordance with the applicable ASTM F1216 provisions for "fully deteriorated gravity pipe conditions." The CIPP lining for other pipe sizes may be designed in accordance with the applicable ASTM F1216 provisions for "partially deteriorated gravity pipe conditions," unless it is noted on the Drawings that "fully deteriorated gravity pipe conditions" shall apply based on reviewing the CCTV video. For sewers where previous CCTV inspection data was not available, the Contractor should submit the completed inspection to determine if "partially deteriorated" or "fully deteriorated" apply. The CIPP lining shall meet the following minimum design conditions, unless the City agrees to the change or as noted on the Drawings:
1. AASHTO H-20 Live Load with two trucks passing
 2. Constrained soil modulus of native soil in the pipe zone = 1,000 psi
 3. Soil weight with 120 pounds per cubic foot and a coefficient of friction of $Ku' = 0.130r$ shall be used for the installed depths.

4. The long-term flexural modulus used in the design calculations shall be estimated by multiplying the lowest short-term flexural modulus specified in the ASTM standards by a long-term retention of mechanical properties factor equal to 50 percent.
5. Design safety factor = 2.0
6. Typical groundwater levels shall be estimated at 1/2 the distance between the pipe's invert and the ground surface. If actual groundwater depth information is available from USGS or other sources, it may be used in the calculations. If the sewer is within 50 feet of a creek or other water body or if indicated on the Drawings, the groundwater depth used in the calculations should be the maximum depth from the ground surface to the pipe crown.
7. Service temperature range shall be 40 °F to 100 °F.
8. Maximum long-term deflection shall be 5 percent.
9. Minimum pipe ovality shall be 2 percent.
10. The CIPP lining thickness to be used shall be the largest thickness as determined by calculations for deflection, bending, buckling, and minimum stiffness.
11. The CIPP shall be designed to withstand all imposed loads, including live loads and, if applicable, hydrostatic pressure. The liner shall have sufficient wall thickness to withstand all anticipated external pressures and loads that may be imposed after installation
12. Submit to the Town of Chapel Hill for approval the structural design for other size sewers and depths or "fully deteriorated" gravity sewers when conditions apply.
13. The minimum lining thickness after installation and curing shall be as follows:

Minimum Lining Thickness Following Installation and Curing* ** ***			
Pipe Diameter (in)	Depth of Sewer to Top of Pipe (ft)	Fully Deteriorated Pipes Minimum Liner Thickness (mm)	Partially Deteriorated Pipes Minimum Liner Thickness (mm)
8-inch	3 to 20	6	N/A
10-inch	3 to 15	6	N/A
10-inch	15 to 20	7.5	N/A
12-inch	3 to 9	6	6
12-inch	9 to 17	7.5	6
12-inch	17 to 20	9	6
15-inch	3 to 9	7.5	6

Minimum Lining Thickness Following Installation and Curing* ** ***			
Pipe Diameter (in)	Depth of Sewer to Top of Pipe (ft)	Fully Deteriorated Pipes Minimum Liner Thickness (mm)	Partially Deteriorated Pipes Minimum Liner Thickness (mm)
15-inch	9 to 15	9	6
15-inch	15 to 20	10.5	7.5
18-inch	3 to 8	9	6
18-inch	10 to 14	10.5	7.5
18-inch	14 to 18	12	7.5
18-inch	18 to 20	12	9

*Chart assumes normal groundwater condition (1/2 distance between pipe invert and ground surface).
**Contractor shall submit calculations for liner thickness in alternate pipe sizes, depths not listed, or if sewer is within 150 feet of a creek or body of water.
***8-inch and 10-inch pipes are always assumed to be Fully Deteriorated.

- S. The CIPP lining shall be watertight.
- T. The CIPP lining shall provide a 50-year service life and shall have the following minimum initial and long-term properties:

Property	Test Method	Initial (psi)	Long-term (psi)
Flexural Strength	ASTM D790	4,500	2,250
Flexural Modulus of Elasticity	ASTM D790	300,000	150,000

2.02 END SEALS

- A. End seals shall be composed of hydrophilic rubber and molded or formed as a one-piece cylinder which when installed will form a 360 degree seal between the host pipe and the newly installed liner. Use of caulking in lieu of an end seal will not be allowed. Acceptable end seals are Insignia™ End Seals by LMK Enterprises, Hydrotite by Greenstreak, or approved equal.

PART 3 - EXECUTION

3.01 PRE-INSTALLATION

- A. The Contractor shall notify all property owners who discharge sewage directly to the sewer being lined that their service will be temporarily discontinued during the CIPP lining installation. The Contractor shall notify individual property owners at least 72 hours in advance, giving the date, start time, and estimated completion time for the work being conducted.
- B. The Contractor shall clean each pipe length to be lined and shall dispose of any resulting material offsite.

- C. The Contractor shall conduct a pre-rehabilitation CCTV inspection for all sewers to be rehabilitated by CIPP lining methods. The inspection shall be to identify pipe defects, to document all service lateral connection locations, and to confirm additional needed point repair locations other than those indicated on the Drawings. The contractor's project manager and/or superintendent shall review the pre-rehabilitation inspection videos to confirm the quality of the videos, locations of lateral connections, and locations of point repairs to be performed; only after the contractor has confirmed that the quality of the videos is adequate for a clear review of the pipeline, they shall be submitted to the Town of Chapel Hill who will review pre-rehabilitation inspection videos to confirm point repair locations to be performed by the Contractor. The Contractor may not proceed with CIPP lining installation until the Town of Chapel Hill has reviewed and approved the Contractor's pre-rehabilitation CCTV inspection data. A minimum of 5 working days shall be provided to review each pre-rehabilitation CCTV inspection data submittal.
- D. The Drawings will provide the Contractor the location for known laterals; however, this list shall not be interpreted as all-inclusive. The Contractor shall be responsible for verifying active customer service connections prior to rehabilitation. If the Contractor discovers an error or addition to the list provided, the Contractor shall immediately notify the Town of Chapel Hill. Upon completing the rehabilitation work, a list with all service laterals abandoned or reconnected as part of the work shall be submitted to the Town of Chapel Hill. The compiled list shall include the following information:
1. Location for each service lateral based on the CCTV inspection logs, which shall include an accurate distance measured from the starting manhole centerline and a notation (by clock-reference) stating where on the pipe circumference the service lateral connects.
 2. Status (Active or Inactive)
- E. During the pre-rehabilitation CCTV inspection and prior to installing the CIPP lining, all protruding service lateral connections greater than or equal to 1/2-inch for less than 18-inch pipe and 3/4-inch for larger pipe shall be internally cut or ground down flush with the pipe wall using a robotic cutter specifically designed for this purpose. The internal cutter shall be able to cut cast iron, PVC, vitrified clay pipe, concrete pipe, ductile iron pipe, and Orangeburg pipe. All materials/cuttings shall be removed from the sewer and properly disposed.
- F. The Contractor shall provide sewage flow bypass pumping in accordance with Section 4.07. Service connection effluent may be plugged only after proper notification to the affected residence and may not remain plugged overnight or longer than 10 hours or approved alternate measures taken. Lining installation shall not begin until the Contractor has installed the required plugs or a sewage by-pass system and until all pumping facilities have been installed and tested under full operating conditions including bypassing mainline, side sewer flows, and services addressed. Once the lining process has begun, existing sewage flows shall be maintained until the resin/felt tube composite has been fully cured, cooled down, fully televised, and the CIPP ends finished..

- G. The Contractor shall furnish and install the CIPP lining in the sewer's full length as shown on the Drawings. The CIPP lining installation shall be in complete accordance with applicable ASTM F1216 provisions and the manufacturer's recommendations.
- H. If the CIPP lining manufacturer believes the infiltration rate in the sewer segment is high enough to risk washing out the resin, the Contractor shall perform required measures to minimize infiltration prior to installation. If any infiltration runners or gushers as defined by NASSCO PACP are observed during the pre-CCTV inspection, the Contractor shall submit in writing for approval by the Town of Chapel Hill the methods and materials for mitigating any adverse impacts from the infiltration. Infiltration runners or gushers that are observed may be stopped by injecting a chemical hydrophilic grouting using a remote packer as an acceptable and preferred method.
- I. The Contractor shall evaluate CIPP liner installations for the potential of adverse odor issues such as from styrene and implement measures including, but not limited to, supplemental ventilation, service plugging, and monitoring in accordance with pertinent state and federal rules and regulations. The evaluations shall include issues that may occur from long duration installations, extended curing times, close proximity to buildings, and/or resident's sensitivities, impairments, or known health conditions relative to respiratory issues.

3.02 INSTALLATION

- A. The CIPP lining for 6-inch through 18-inch sewers without sags greater than 30% may be installed via inversion using hydrostatic head or air pressure or pull-in methods in accordance with ASTM F1216 and manufacturer's recommendations.
- B. The Contractor shall install a hydrophilic seal at each manhole face prior to inverting or pulling in the uncured CIPP lining.
- C. If the CIPP lining does not fit tightly against the original pipe at its termination points, at no additional cost to the Town of Chapel Hill, the full circumference of the CIPP lining exiting the host pipe shall be filled with a resin mixture compatible with the CIPP and approved by the CIPP manufacturer. There shall be no groundwater leakage between the existing pipe and the CIPP lining at the manhole connection or service lateral connections. Any leakage found shall be eliminated by the Contractor at no additional cost to the Town of Chapel Hill.
- D. The installed CIPP lining shall be cured using circulating heated water or steam in accordance with ASTM F1216 and manufacturer's recommendations for sewers 18-inch diameter and smaller with temperature monitoring at manholes and service openings if available. For sewers greater than 18-inch diameter, the installed CIPP lining shall only be cured using circulating heated water in accordance with ASTM F1216 and manufacturer's recommendations.
- E. The resin-impregnated flexible felt tube lining shall be processed to affect the desired cure throughout the tube's length, extending full length from manhole to manhole(s). The resin shall be cured into a hard impermeable pipe of the

minimum specified thickness, providing a structurally sound, uniformly smooth interior and tight-fitting lining within the existing pipe.

- F. Cool-down procedures shall be in accordance with ASTM F1216 and manufacturer's recommendations.
- G. UV cured CIPP will not be permitted without written approval from the Town of Chapel Hill and after reviewing the documentation to ensure the lining is compatible with all specifications and other related work including any lateral lining systems.
- H. The Contractor may install CIPP lining in multiple sewer segments at one time where possible. When installing CIPP lining in multiple sewer segments at one time, remove the top 1/2 of the CIPP lining in the intermediate manhole and fill the void between the CIPP lining and existing channel with non-shrink grout. The manhole bench shall be reconstructed as required to provide a smooth transition to the new CIPP lining.
- I. Temperature monitoring systems shall be required for all 18-inch or larger sewers, any sized sewer that crosses a stream, creek, or other body of water, or as noted on the Drawings. This system shall be installed at the pipe invert per the manufacturer's recommended procedures. The temperature sensors shall be placed at intervals as recommended by the sensor manufacturer. Additional sensors shall be placed where significant heat sinks are likely or anticipated. The sensors, if installed, shall be monitored by a computer using a tamper proof database which can record temperatures at the lining interface and the host pipe. Provide the Town of Chapel Hill with access to the longitudinal temperature monitoring system data during the installation via digital data, web-based or other approved methodology and printed reports. Temperature monitoring systems shall be Zia Systems or Vericure by Pipeline Renewal Technologies.
- J. If cool-down is to be accomplished by introducing cool water into an inversion standpipe to replace the water being drained from a small hole made in the downstream end, cool the hardened pipe to a temperature below 100 °F (38 °C) before relieving static head in the inversion standpipe. When releasing static head, ensure a vacuum will not be produced that could damage the newly installed CIPP lining.
- K. Vent and/or exhaust noxious fumes or odors generated during and remaining after the curing process has been completed. This process shall remain in place at all manholes, laterals, etc., until noxious odors have dissipated to an acceptable level in accordance with OSHA requirements for the materials used and there is no potential health hazard left to the general public or the construction workers.
- L. Identify and submit for approval to the Town of Chapel Hill the points to where curing water will be discharged if other than the downstream sanitary sewer system at acceptable discharge rates. NO discharge to storm sewers or drainage systems shall be allowed.
- M. Provide piping, pumps, valves, and other equipment to discharge curing water.

- N. All cutting and sealing of CIPP liner at manhole connections and/or walls shall provide watertight pipe and manhole seals. All cut edges of cured liner shall be thoroughly sealed with same resin as was used in liner. Catalyst or hardener used shall be compatible with resin/catalyst used in liner previously but shall not require an external heat source to begin exothermic reaction (curing). There shall be no leakage of groundwater into manhole between CIPP liner and existing sewer pipe and between existing sewer pipe and manhole wall.
- O. The installed CIPP lining shall be continuous over the sewer line section's entire length and be free from visual defects such as foreign inclusions, dry spots, pinholes, fins, major wrinkles, and delamination. The lined invert and lower third of the pipe in normal wastewater flow depth shall be of particular concern to defect avoidance. The CIPP lining shall be impervious and free from any pipe leakage to the surrounding ground or from the ground to inside the lined pipe.

3.03 REINSTATING SERVICES

- A. After the new CIPP lining has been cured and completely cooled down, the Contractor shall reconnect the existing service laterals as designated by the pre-installation CCTV report generated by the Contractor. This shall be done without excavation from the pipeline's interior using a television camera and a remote cutting device that reestablishes the service connection to not less than 90 percent of the original diameter. All connections between the CIPP lining and the service connection shall be watertight. All openings shall be clean and neatly cut, and the cut shall be buffed with a wire brush to remove rough edges and provide a smooth finish. The bottom of the openings shall be flush with the bottom of the lateral pipe with no protruding material able to hinder flow or catch debris.
- B. For service renewals by excavation methods, InsertaTeEs may be used for solid wall pipes having a 0.36-inch or greater wall thickness. InsertaTeEs shall be "Fatboy" type with hub manufactured of SDR 26 PVC material incorporating a 360 degree integral stop on the hub surface and exceeding ASTM F1336 Section 10.3 Pipe Stop Load Support Test, or approved equal. Romac type saddles shall be used for pipes having a wall thickness thinner than 0.36-inches.
- C. Inactive service laterals will be abandoned by not reopening the service connection after installing the CIPP lining.
- D. Provide a fully operational backup device for reinstating service laterals. If for any reason the remote cutting device fails during a service lateral's reinstatement, immediately deploy the standby device to complete the reinstatement. The backup device shall be fully functional without needing to remove parts from the primary device. The backup equipment shall be on site throughout the reinstatement process.

3.04 FIELD TESTING AND ACCEPTANCE

- A. The Contractor shall perform a 4 psi air test on each CIPP lining segment in the Town of Chapel Hill's presence after curing the CIPP and prior to internally reinstating laterals on all 18-inch and smaller diameter sewers. Larger diameter

sewers will be visually inspected only by CCTV for no visible leaks. The CIPP shall be able to hold a 4 psi pressure for a 5-minute minimum duration after a 2-minute stabilization period. Any lining not able to meet this testing requirement shall be repaired and retested at no additional cost to the City.

- B. Field acceptance for the CIPP lining shall be based on the Town of Chapel Hill's evaluation of the installation including reviewing the CIPP lining curing data, the post-rehabilitation CCTV inspection data, the certified test data for the installed CIPP lining, and CIPP air testing results. All CIPP sample testing and repairs to the installed CIPP as applicable shall be completed and documented in written form before final acceptance.
- C. For every 1,000 linear feet for pipe less than 24-inches in diameter of CIPP lining installed, the Contractor shall perform sampling and testing to determine the installed CIPP lining's flexural properties and thickness. After 10,000 feet of acceptable test results have been received, the Town of Chapel Hill may reduce the test sample frequency to one sample every 2,000 feet from the same wet-out batch, as long as samples continue to meet all minimum standards and sampling results are received in a timely manner. The testing frequency may be increased by Town of Chapel Hill and performed by the Contractor at no additional cost to the Town when the required tests show the installed CIPP lining does not meet the specifications.
- D. Tests shall be performed by an independent testing laboratory certified by the American Association for Laboratory Accreditation (A2LA). The Contractor shall submit to the Town of Chapel Hill the name and location for the independent testing laboratory, a certified statement from the laboratory indicating they are independent from and not associated with the Contractor in any way, and the ASTM certification for the independent testing laboratory.
- E. All expenses for sampling and testing the installed lining shall be paid by the Contractor. The cost for all manufacturers' testing to qualify products furnished to the project site shall be the Contractor's responsibility.
- F. Sampling and testing for the installed CIPP lining shall conform to the following requirements.
 - 1. Remove one restrained sample of the installed CIPP lining at least 18-inches in length. The sample shall be captured by installing the CIPP lining through a section of PVC or similar cylindrical tube (same diameter as the existing sewer diameter) within the installation's most downstream manhole and at all intermediate manholes if multiple sewer segments are lined at the same time. The Contractor may elect to cut the sample longitudinally and take 1/2 the sample for direct shipping to the laboratory and keep the other sample 1/2 for additional testing if necessary.
 - 2. For sewers 18 inches in diameter and larger, a minimum of two plate samples formulated out of the same felt blend and resin mixture as the installed liner shall be prepared and cured in the downtube of the installation column.

3. The CIPP lining thickness shall be measured in accordance with *ASTM D5813*. *Flexural properties shall be determined in accordance with ASTM D790*. The Contractor shall label and date all samples for shipping to the independent testing laboratory. The Town of Chapel Hill shall be copied on all transmittals to the independent testing laboratory. Testing results shall be submitted to the Town of Chapel Hill within 30 days after installing the CIPP lining or payment will be withheld.
4. Any CIPP lining not meeting the specified installed strength and/or thickness requirements, regardless of the amount below the specified requirements, shall not be approved for payment until the deficiency has been corrected by the Contractor in a manner approved by the Town of Chapel Hill at no additional cost to the Town. Options considered for correcting deficient CIPP lining installations include the following.
 - a. Remove the existing CIPP lining and re-line the sewer.
 - b. Provide open-cut sewer replacement from manhole to manhole.
 - c. Re-line the sewer with the existing CIPP lining in place. Note that this will not be accepted if Town of Chapel Hill determines that the sewer section has capacity concerns.
 - d. Accept the following penalties depending on the structural and thickness test results.
 - 1) If the tests are within 90 percent of the specification, the payment reduction shall be 10 percent of the bid price per item.
 - 2) If the tests are between 75 percent and 89 percent of the specification, then 75 percent of the bid price shall be paid.
 - 3) If the tests are below 75 percent, the Contractor must reline or replace the segment.
- G. The Contractor shall perform a post-rehabilitation CCTV inspection for all sewers rehabilitated using CIPP lining methods. The post-rehabilitation CCTV inspection shall be performed following the CIPP lining installation and reinstating all active service laterals. The Contractor's project manager and/or superintendent shall review the post-rehabilitation inspection videos to confirm the quality of the videos and of the installed CIPP; only after the Contractor has confirmed that the video is of good quality, the videos shall be submitted to the Town of Chapel Hill. If it is determined that any repairs are needed at any segment, a new CCTV inspection shall be performed of the entire segment(s) after the repairs have been completed.
- H. The Town of Chapel Hill shall review and approve payment based on the Contractor having satisfactorily completed a lining free from significant defects. The finished lining shall be continuous between manholes and shall be free from

visual defects such as foreign inclusions, reverse curvatures, splits, flats, cracks, lifts, kinks, wrinkles, flats, dry spots, pinholes, shrinkage, crazing, leaks, and delamination. The maximum allowable size for wrinkle or bulge as shown in the inspection shall not exceed 3 percent of equivalent pipe diameter or 1-inch by visual measurement, whichever is smaller. No wrinkles will be allowed in the invert of pipe between 4:00 and 8:00 o'clock positions.

- I. Contractor will be responsible to remove and repair, at Contractor's expense, all such defects in a manner that is satisfactory to the Town of Chapel Hill.
- J. Shrinkage of the CIPP liner's length, of more than two (2) inches for pipe diameters less than 18-inch and three (3) inches for 18-inch or larger diameter from the face of the manhole shall be repaired with a fiberglass reinforced CIPP spot repair at no cost to the City.
- K. The cured CIPP lining and all pipe-to-manhole connections shall be watertight and free from infiltration.
- L. Following rehabilitation or replacement of the service laterals, the Contractor shall perform an air test in the Town of Chapel Hill's presence for each 18-inch and smaller segment lined or may test each lateral and connection area individually in lieu of the full segment air test.

3.05 CLEANUP

- A. Upon the installation work and testing acceptance, restore the project area affected by the operations to a condition at least equal to what existed prior to the work.

END OF SECTION

SECTION 4.05

SEWER SERVICE LATERAL LINING

PART 1 - GENERAL

1.01 DESCRIPTION

- A. Furnish all labor, materials, equipment, and incidentals required to install cured-in-place pipe (CIPP) lining to rehabilitate existing active service laterals as directed by the Town of Chapel Hill. Service laterals shall be lined from the connection with the main sewer to the property line or easement edge, unless otherwise noted or approved by the Town of Chapel Hill. A brim seal connection style, or full-wrap style lining shall be used to address the connection between the main sewer and the service lateral.
- B. Furnish all labor, materials, equipment, and incidentals required to conduct air testing, post-rehabilitation CCTV inspections, and other requirements described herein for final service lateral lining acceptance.
- C. This specification shall also apply to installing CIPP lining for laterals discharging directly into manholes, if the pipe diameter is 6-inch or less.
- D. Service laterals may be a combination of tees, wyes, or break-in taps of varying sizes (4-inch to 8-inch) with angles generally ranging up to 90 degrees. In most cases, a cleanout will be installed at the property line or easement edge.
- E. If any active service laterals are identified as defective and the Contractor is unable to line the lateral from the main sewer to the property line or easement edge, the Contractor shall inform the Town of Chapel Hill about the lateral's condition and shall propose a rehabilitation method that maximizes the lateral's rehabilitated length while minimizing the extent of surface disruption. The Town of Chapel Hill will direct the Contractor as to the acceptable approach for rehabilitating or replacing the service lateral in question.

1.02 SUBMITTALS

- A. Submit the following in accordance with Section 2.04:
 - 1. Shop drawings and schedules for all service lateral lining and appurtenances required
 - 2. Design data and specification data sheets listing all parameters used in the lining design
 - 3. Thickness calculations based on ASTM F1216-09, Appendix XI.1.2 for fully deteriorated pipe
 - a. All service lateral lining design calculations shall be sealed and signed by a Tennessee registered professional engineer.
 - 4. Detailed procedure for installing the service lateral lining

5. The service lateral lining manufacturer's name and the facility location where the service lateral lining will be manufactured
6. A licensed and certified trainer and representative from the lining system manufacturer shall be on-site to assist in the work for a minimum of one (1) week.
7. The Contractor shall be an approved installer as certified and/or licensed by the lining manufacturer.
8. Material Certifications. Written certification is required from the manufacturer stating all materials used in the work were manufactured and tested in accordance with ASTM F1216 and is being used or installed in conformance with the manufacturer's recommendations.
9. Storage and Delivery Procedures. Provide the lining manufacturer's recommended storage and delivery procedures. This shall include storage and delivery temperatures, maximum time from wet-out to installation, and other pertinent information.
10. Material Safety Data Sheets. Submit Material Safety Data Sheets (MSDS) for each component of the service lateral lining system.
11. Test Results. Prior to using any materials, furnish the proposed material's test results from an independent laboratory in conformance with these specifications. All submitted test data shall have been performed on field installed samples within the last 12 months. Testing by an independent laboratory shall verify the products to be used meet all minimum strength standards as set forth in ASTM F1216, Table 1. Testing shall also verify any product to be used on the project meets the minimum chemical resistance requirements as established in ASTM F1743, Table 2, where the testing is in accordance with Section 7.2.1 of ASTM F1743.
12. Pipe Cleaning Narrative. Submit a narrative describing in sufficient detail the proposed methods for root cutting and cleaning the existing laterals. Prepare such narrative to include the degree of cleaning as recommended by the lining manufacturer. Such narrative shall indicate the lining manufacturer's technical representative's approval for the proposed cleaning methods.
13. Lining Thickness Calculations. Perform lining thickness calculations for each size of laterals and furnish them to the Town of Chapel Hill with supporting assumptions. Calculations shall be done after cleaning, televising, and other field inspections have been accomplished. Design parameters shall be used in calculations.
14. Curing Cycle and Cooling Rate. If the lateral lining is heat-cured, submit the resin manufacturer's recommended curing cycle and the recommended cooling rate. Submit a copy of the cure logs for each lateral installation.
15. Post-lining inspection data. Submit the final television inspection in a Granite XP compatible database that shows the rehabilitated laterals.

1.03 REFERENCE STANDARDS

- A. American Society for Testing and Materials (ASTM)
 - 1. ASTM D790 – Standard Test Methods for Flexural Properties of Unreinforced and Reinforced Plastics and Electrical Insulating Materials
 - 2. ASTM F1216 – Standard Practice for Rehabilitation of Existing Pipelines and Conduits by the Inversion and Curing of a Resin-Impregnated Tube
 - 3. ASTM F2561 – Standard Practice for Rehabilitation of a Sewer Service Lateral and its Connection to the Main Using a One Piece Main and Lateral Cured-in-Place Liner
 - 4. ASTM F1743 – Standard Practice for Rehabilitation of Existing Pipelines and Conduits by Pulled-in-Place Installation of Cured-in-Place Thermosetting Resin Pipe (CIPP)
 - 5. ASTM D2990 – Standard Test Methods for Tensile, Compressive, and Flexural Creep and Creep-Rupture of Plastics

1.04 QUALITY ASSURANCE

- A. The Contractor performing the service lateral lining work shall be experienced and equipped to complete this work expeditiously and in a satisfactory manner.
- B. Be able to provide crews as needed to complete the work without undue delay and within the contract time allotted.
- C. The service lateral lining shall be provided by a single manufacturer. The supplier shall be responsible for providing all test requirements specified herein as applicable.
- D. The Town of Chapel Hill may inspect the service lateral lining after delivery. The service lateral lining shall be subject to rejection at any time if it fails to meet any requirements specified, even though sample lining may have been accepted as satisfactory at the manufacturer. Lining rejected after delivery shall be marked for identification and removed from the job site at once.
- E. Final Installed Lining Thickness. The final installed lining thickness shall not be less than or more than 10 percent greater than the required thickness. The final installed lining thickness measurement shall be determined from lining sample coupons retrieved from the sewer, plate samples or as deemed necessary by the Engineer. It shall be the Contractor's responsibility to consider site conditions and their installation process to determine the proper lining thickness to install.
- F. Non-Compliance. If the flat plate samples do not meet the required 4,500 psi flexural strength and 250,000 psi flexural elasticity modulus as outlined, actual installed samples must be taken. The installed samples shall be taken as directed by the Town of Chapel Hill and in accordance with all applicable ASTM requirements. From these samples, the installed thickness shall be determined by taking an average of at least 10 thickness measurements. Installed samples shall then be prepared for re-testing in accordance with these specifications.

1.05 DELIVERY, STORAGE AND HANDLING

- A. Care shall be taken in shipping, handling, and storing to avoid damaging the service lateral lining. Extra care shall be taken during cold weather construction. Any lining damaged in shipment shall be replaced as directed by the Town of Chapel Hill.
- B. Any lining showing a split or tear, or which has received a blow that may have caused damage, even though damage may not be visible, shall be marked as rejected and removed at once from the job site.
- C. At all times, the lining materials, including the wet-out lining, shall be maintained at a proper temperature, such as in refrigerated facilities, to prevent premature curing prior to installation. The lining shall be protected from UV light prior to installation. Any lining showing evidence of premature curing will be rejected for use and will be removed from the site immediately.

1.06 PUBLIC NOTIFICATION

- A. Notify the owners and residents of any homes or businesses whose service lateral will be affected by the lining work. Also, deliver written notification to each such resident or business 3 days prior to such lining work, further advising of the work. Include in the notifications any restrictions on using the sewage system facilities. Describe exact days and hours when the sewer system cannot be used. **CONTACT ANY HOME OR BUSINESS THAT CANNOT BE RECONNECTED WITHIN TIME STATED IN THE WRITTEN NOTICE.**
- B. **THE MAXIMUM TIME ANY HOME OR BUSINESS SHALL BE WITHOUT SANITARY SEWER SERVICE IS 10 HOURS and NOT BETWEEN 6:00 PM AND 8:00 A.M. ANY SERVICE OUT LONGER THAN 10 HOURS WILL HAVE SERVICE RESTORED AT CONTRACTOR'S EXPENSE OR TEMPORARY MEASURES TAKEN.**

1.07 GUARANTEE

- A. All lining work shall be fully guaranteed by the Contractor and manufacturer for 3 years from the acceptance date. A written warranty shall be submitted. During this period, all serious defects, including failure of the seal between the service lateral lining and the main sewer, discovered by Metro shall be removed and replaced by the Contractor in a satisfactory manner at no additional cost to the Town of Chapel Hill. At their own expense, Town of Chapel Hill may conduct an independent television inspection of the lining work prior to the guarantee period's completion. Any defects replaced at that time shall be fully guaranteed by the Contractor and manufacturer for one year from the date the defect was repaired. Wrinkles, blisters, dry spots in resin, or other defects in the finished service lateral, which in the Town of Chapel Hill opinion, negatively affect the service lateral's integrity or strength or the pipe's flow capacity or performance of solids passage are unacceptable. Contractor will be responsible to remove and repair, at Contractor's expense, all such defects in a manner satisfactory to the Town of Chapel Hill. Defects also include but are not limited to the following:
 - 1. Leakage through the lining or between lining and pipe
 - 2. More than 10 percent reduction in the lining thickness
 - 3. Lining separating from the pipe

- 4. Excessive wrinkles inhibiting flow
- B. The lining shall be as free as commercially practicable from visual defects such as foreign inclusions, dry spots, pinholes, and delamination. The lining shall have a smooth surface free from leaks, cracks, and crazing. Some minor waviness that, in the Town of Chapel Hill opinion, will not appreciably decrease the flow cross-section or affect the flow characteristics shall be permissible.

1.08 WATER

- A. Water for all construction operations shall be available from City fire hydrants at normal commercial rates.
- B. Water usage shall be in accordance with City backflow and metering polices.

PART 2 - PRODUCTS

2.01 MATERIALS

- A. The service lateral lining shall be a seamless, corrosion-resistant, cured-in-place pipe lining product that seals the service lateral pipe and the junction between the service lateral pipe and main sewer. The portion of the lateral lining system that connects to the main/lateral interface shall be either a full-wrap or brim-seal connection type.
- B. The service lateral lining shall be a resin-impregnated, flexible polyester felt, non-woven textile tube, needle punched felt, circular knit or circular braid, glass fiber reinforced plastic or equivalent material tube which is cured -in-place by an acceptable curing method. The tube shall be able to conform to bends, offset joints, bells, and disfigured pipe sections.
- C. The service lateral shall provide a 50-year service life and shall have the minimum structural properties listed below:

Minimum Structural Properties	
Physical Properties	Minimum Standard
Flexural Strength (ASTM D790)	4,500 psi
Flexural Modulus of Elasticity (ASTM D790)	250,000 psi

- D. The service lateral shall be designed, fabricated, and installed for the actual conditions encountered for this application including the host pipe material, in accordance with the applicable ASTM F1216, ASTM D2990 provisions, and shall meet the following minimum design conditions:
 - 1. AASHTO H-20 live load with two trucks passing
 - 2. Soil Weight 120 pounds per cubic foot
 - 3. Friction coefficient $Ku'=0.130$
 - 4. Estimated maximum groundwater level at ground surface
 - 5. Fully deteriorated pipe with 2 percent (min.) ovality. If existing pipe's ovality is found to be worse, use actual percent up to 5 percent (max.).

6. Soil Modulus 1,000 psi
 7. Safety factor = 2
 8. Soil Depth: The cover depth will be determined by field measurements.
- E. The finished lining shall have a 3 mm minimum thickness for 4-inch laterals and 4.5 mm for 6-inch laterals.
 - F. The service lateral lining shall have sufficient wall thickness to withstand all anticipated external pressures and loads that may be imposed after installation. The design shall be performed and certified by a Tennessee registered professional engineer.
 - G. The service lateral lining shall be manufactured and installed by T-Liner by LMK Technologies; SCS+L by BLD Services, LLC; epros DrainMtH System by Trelleborg Pipe Seals Milford, Inc.; or approved equal.
 - H. When cured, the service lateral lining shall extend from the mainline into the lateral connection in a continuous tight fitting, watertight pipe-within-a-pipe to eliminate any visible groundwater leakage and future root growth at the lateral to mainline connection and along the lateral. The service lateral product system shall be compatible with the mainline and/or lateral pipe or lining. The lining portion within the mainline pipe may be a full-wrap or brim-seal connection or style.
 - I. When cured, the finished service lateral product shall be chemically resistant to domestic sewage over the rehabilitated pipe's expected lifetime. The lining material and resin shall be completely compatible.
 - J. The connection between the service lateral and the main sewer shall be lined so a continuous overlap between the service lateral lining and the main sewer extends 3-inches minimum from the lateral along the entire circumference.
 - K. A leak-free seal must be created to form a sealing bond between the service lateral product and the host lateral and mainline pipe walls. The Contractor should use either a hydrophilic material or an epoxy-sealing component at each lining tube end to provide a leak-free seal.
 - L. When cured, the lining shall form a hard, impermeable lining which is chemically resistant to chemicals found in domestic sewage.

2.02 RESIN

- A. The resin system shall meet the requirements of ASTM F1216, Section 5.2. The resin installed service lateral lining system shall produce a service lateral that will comply with the structural requirements specified herein and shall provide chemical resistance for the flow media in the gravity pipe. The resin shall be compatible with the rehabilitation process, shall be able to cure in water's presence or absence and shall have an initiation temperature for cure as recommended by the resin manufacturer. Unless otherwise specified, provide a general purpose or enhanced strength unsaturated, thermosetting, polyester, vinyl ester, epoxy or silicate resin and a catalyst system compatible with the installation process. The resin shall be vacuum impregnated into the lining.
- B. Submit documentation from the resin manufacturer specifically describing the resin system's chemical characteristics including allowable mixing, impregnation, and handling time, transportation, and storage time, and recommended curing cycle including

temperatures, pressures, and times. The resin manufacturer's documentation must also include maximum allowable time for handling the impregnated tube prior to insertion and the maximum allowable elapsed time from insertion to exotherm. If remedial measures are available to extend either of the maximum allowable times indicated above, without affecting the resin's physical properties, the resin manufacturer should describe these measures and the time limits beyond which even these measures will not prevent altering the resin's physical properties.

PART 3 - EXECUTION

3.01 PRE-INSTALLATION

- A. A digital CCTV video inspection must be done on the mainline pipe with a pan and tilt camera and the service lateral to confirm the proposed repair falls within the limitation parameters set by the manufacturer on the following aspects:
1. The location and clock reference of the lateral junctions to be lined
 2. Any offsets, any intrusions from the lateral into the main
 3. Angle at which the connection comes in
 4. Any changes in the lateral's approach angle for the repair length
 5. Potential flows coming throughout the lateral pipe
 6. Potential flows going through the main pipe
 7. Diametric connection size for the lining length
 8. Main pipe's size at the service lateral point
 9. Service lateral's condition including the presence of debris, turns, bends, changes in diameter, or other observations
 10. Active infiltration present within the work area vicinity
 11. Any defects noted in the mainline pipe or lateral should be documented using NASSCO PACP/LACP Standards.
- B. Inform the Town of Chapel Hill about service laterals in which a service lateral lining cannot be installed from the main sewer to the cleanout established at the property line or easement line. The Contractor shall identify these service laterals and provide the Town of Chapel Hill with documentation about the conditions encountered including the CCTV inspection. If a full-length lateral lining cannot be installed or a point repair on the service cannot be performed, the Town of Chapel Hill may direct the Contractor to install a short lateral lining with no cleanout required extending up the lateral from the main. The length is to be field determined to the maximum length possible, but should extend 3 feet minimum up the lateral from the main
- C. Inform the Town of Chapel Hill about service laterals in which a short length service lateral product cannot be installed. The Contractor shall identify, document, and video record these services and inform the Town of Chapel Hill about the conditions encountered. If a short length lateral lining cannot be installed, the service connection will be "cut and buffed" to restore a 95% minimum service opening.

3.02 LINE PREPARATION

- A. Prior to installing the service lateral product, the area around the lateral sealing surface in the main and lateral shall be inspected. Waste product build-up, hard scale, roots, lateral cutting debris, or resin slugs must be removed using high-pressure water jetting or in-line cutters. All laterals to be lined shall be cleaned as required prior to lining. The term “cleaned” shall mean removing all sand, dirt, roots, grease, and other solids or semisolid materials from the interior face of the sewer mainlines and the service laterals.
- B. Built-up deposits on the main and lateral pipe walls shall be removed. The removal shall reach at least 1 foot beyond the scheduled service lateral installation length to allow the bladder to inflate tightly against the pipe walls ensuring a smooth transition from service lateral product to the existing pipe wall.
- C. Televis the lateral to provide a detailed record of existing conditions and lateral connections. Have a copy of the pre-lining inspections in the field. Immediately prior to lining insertion, the camera shall traverse the lateral to inspect for debris which may have entered the line after the existing condition inspection.
- D. Where active infiltration is present and when it is recommended by the service lateral lining manufacturer, the infiltration must be stopped in advance by grouting.
- E. Additional precautions need to be taken when applying the sleeve to a main pipe lined with a CIPP lining with a polyolefin coating. The coating is to be lightly scarified, scraping off the coating in the main CIPP in the service lateral lining’s vicinity, and verified by the Town of Chapel Hill. This scuffing is mandated for service lateral linings required to adhere to the pipe wall. Service lateral linings with hydrophilic material are not required to have the existing lining scarified.
- F. The Contractor shall be responsible, if needed, for bypassing sewage while installing the service lateral lining product. In cases where the temporary sewage backup is accepted as a replacement for bypassing, the Contractor shall be responsible for all damage caused by sewage backing up into properties or sanitary sewer overflows.

3.03 INSTALLATION

- A. The service lateral lining shall be vacuum-impregnated with resin (wet-out) under controlled conditions. The resin volume used shall be sufficient to fill all voids in the textile lining material at nominal thickness and diameter. The volume shall be adjusted by adding 5% to 10% excess resin for the change in resin volume due to polymerization and to allow for any resin migration into the cracks and joints in the original pipe. All resin shall be contained within the translucent bladder during vacuum impregnations. No dry or unsaturated area in the lateral tube shall be acceptable upon visual inspection.
- B. The service lateral product shall be loaded on the applicator apparatus, attached to a robotic manipulator device, and positioned at the cleanout or pipe opening of the service connection that is to be rehabilitated. For service lateral full-wrap style linings with compression gaskets, the mainline lining and bladder shall be wrapped around the "T" launching device and held firmly by placing 4 hydrophilic material bands around the main lining. For service lateral full-wrap linings that do not use hydrophilic material, a 300 ml volume adhesive sealant shall be applied to the main/lateral interface and shall be applied as a 2-inch wide band on the main lining. For service lateral brim-sill connection style linings, 300 ml minimum volume excessive resin or hydrophilic materials shall be applied to the main/lateral interface and shall be applied as a band on the main brim-seal. The robotic device with a television camera shall be used to align the repair product with

the service connection opening. The insertion pressure shall be adjusted to fully deploy the service lateral product into the lateral connection and hold the service lateral product tight to the main and lateral pipe walls.

- C. The pressure apparatus shall include a bladder with sufficient length in the main and lateral lines so the inflated bladder extends beyond the ends of the service lateral product's lateral tube and main line tube, pressing the end edges flat against the internal pipe wall, thus forming a smooth transition from service lateral product to pipe diameters without a step, ridge, or gap between the service lateral product and the lateral and mainline pipes' inner diameters.
- D. For service lateral linings with hydrophilic materials, the main bladder shall be inflated causing the main sheet to unwrap and expand, embedding the hydrophilic material between the main lining and the main pipe as the main lining is pressed tight against the main pipe.
- E. After insertion is completed, recommended pressure must be maintained on the impregnated service lateral product according to ASTM F1216-09, Sections 7.4.2 and 7.4.3, pressing the lining firmly against the inner pipe wall during the entire curing process. The lining shall be cured at ambient temperatures or by a suitable heat source. In no instance will sewage be used to invert or cure linings or calibration tubes.
- F. The finished service lateral lining shall be free from dry spots, lifts, and delamination. The installed service lateral lining should not inhibit the CCTV post installation video inspection for the mainline and service lateral pipes or future pipe cleaning operations. For service lateral linings with compression gaskets, the CIPP shall taper at each end providing a smooth transition to accommodate video equipment and maintain proper flow in the mainline. In all cases, the finished product must provide an airtight/watertight verifiable non-leaking connection between the main sewer and sewer service lateral. During the warranty period, any defects with the service lateral that affect the lateral connection's performance, cleaning, or water tightness shall be repaired at the Contractor's expense in a manner acceptable to the Town of Chapel Hill.
- G. Following the lining installation, provide the Town of Chapel Hill with an electronic picture and recorded data identifying the location and showing the completed work and restored condition for all the rehabilitated service laterals from the sewer main to the service reconnection point. The Contractor shall televise the rehabilitated lateral to provide a detailed record of finished conditions using NASCCO PACP/LACP guidelines. When complete, the Contractor shall submit the rehabilitated lateral inspections in a Granite XP-compatible database and the accompanying logs on DVDs or an external USB hard drive.

3.04 FIELD TESTING AND ACCEPTANCE

- A. The lining's field acceptance shall be based on the Town of Chapel Hill's evaluation of the installation including post-lined digital CCTV inspection and reviewing certified test data for the installed pipe samples. The CCTV inspection for each lateral shall extend 10 feet minimum past the end of the rehabilitation work on the service lateral. For laterals where a cleanout was installed, the CCTV inspection shall include the cleanout and the connection to the existing, undisturbed service lateral.
- B. The lining shall have zero groundwater infiltration, and each lateral must pass a 2-minute 4 psi air test conducted by the Contractor.

- C. A flat plate sample shall be collected for every 50 lateral installations, and the sample shall be submitted to a third party testing laboratory to confirm strength properties (flexural strength and flexural modulus) in accordance with ASTM F1216. The test results must meet or exceed the strengths in the design, or the Contractor must provide a 10% credit for up to 50 laterals the sample represents.
- D. All service connections shall be open, clear, and watertight.
- E. The lining shall have no evidence of splits, cracks, breaks, lifts, kinks, delaminations, or crazing.
- F. If any defective lining is discovered after it has been installed, it shall be removed and replaced by the Contractor with a new lining, a new pipe, or other measures with the Town of Chapel Hill approval at no additional cost to the Town of Chapel Hill. Any lining installation not meeting specified strengths or thickness shall provide other acceptable remediation measures or credit as approved by the Town of Chapel Hill. The re-inspection requirements as listed above shall apply to this re-installed section of line.

3.05 CLEANUP

- A. After the installation work and testing have been accepted, restore the project area affected by the operations to a condition at least equal to what existed prior to the work.

END OF SECTION

SECTION 4.06

SANITARY SEWER MANHOLE REHABILITATION

PART 1 - GENERAL

1.1 SECTION INCLUDES

- A. Sanitary sewer manhole rehabilitation including:
 - 1. Level “Yellow” Rehabilitation - Rehabilitation and leak-proofing of manholes by lining with spray applied or centrifugally cast lightweight structural reinforced concrete.
 - 2. Level “Blue” Rehabilitation - Rehabilitation and leak-proofing of manholes by lining with spray applied epoxy resin systems.
 - 3. Level “Green” Rehabilitation - Rehabilitation and leak-proofing of manholes as specified by Level “Yellow”, and followed by lining with spray applied epoxy resin systems as specified by Level “Blue”.
 - 4. The repair and sealing of the manhole base, invert, walls, corbel/cone, and chimney of brick, block, or precast manholes, including the removal of any unsound material.
 - 5. The inspection and testing of the various types of work to insure compliance.

1.2 LINING SYSTEMS

- A. The lining system used shall result in a monolithic structure to the shape and contour of the interior of the existing manhole. The lining system shall be completely water tight and free of any joints or openings other than pipe inlets, pipe outlets and the rim opening. The junction of the lining material with the pipe material at the inlets and outlets shall be watertight.
- B. Lining system shall be of the type that allows rehabilitation of a concentric, eccentric or flat top manhole without removing the manhole ring and top section or corbel.

1.3 SUBMITTALS

- A. Submit the following as required in Section 2.04 at least 14 days prior to starting manhole rehabilitation:
 - 1. Manufacturers’ Certificate of Compliance certifying compliance with the applicable specifications and standards. The certifications shall list all materials furnished under this Section.

2. Certified copies of test reports of factory tests required by the applicable standards, the manufacturer, and this Section.
3. Manufacturer's handling, storage, and installation instructions and procedures.
4. Recommended lining thickness design to withstand groundwater pressure as specified in Part 3 of this Section.

PART 2 - PRODUCTS

2.1 MATERIALS

A. General:

1. The materials used shall be designed, manufactured and intended for sewer manhole rehabilitation and the specific application in which they are used. The materials shall have a proven history of performance in sewer manhole rehabilitation. The materials shall be delivered to the job site in original unopened packages and clearly labeled with the manufacturer's identification and printed instructions. All materials shall be stored and handled in accordance with recommendations of the manufacturer. All materials shall be mixed and applied in accordance with the manufacturer's written instructions.
2. The Contractor shall warrant and save harmless the Owner and his Engineer against all claims for patent infringement and any loss thereof.
3. Handle and store all materials and dispose of all wastes in accordance with applicable regulations.
4. Each system shall be designed for application over wet surfaces (but not active running water) without degradation of the final product and/or the bond between the product and the manhole surfaces.

B. Stopping active leaks in concrete and masonry manholes:

1. A quick setting hydraulic cement compound used to stop seepage leaks in masonry or concrete (Permacast-Plug or equal). A premixed fast-setting, volume-stable waterproof cement plug consisting of hydraulic cement, graded silica aggregates, special plasticizing and accelerating agents. It shall not contain chlorides, gypsums, plasters, iron particles, aluminum powder or gas-forming agents, or promote the corrosion of steel it may come in contact with. Set time shall be approximately 60 to 180 seconds. Ten-minute compressive strength shall be approximately 500 psi.
2. The elastomeric polyurethane resin-soaked method, using dry twisted jute oakum or resin-rod with polyurethane resin (water activated).

3. Chemical grouts (Avanti AV-202 Multigrout Urethane Resin or equal) injected to the exterior for stopping *very* active infiltration in accordance with manufacturer's recommendations.
- C. Patching, repointing, filling, and repairing nonleaking holes, cracks, and spalls in concrete and masonry manholes:
1. A premixed nonshrink cement-based patching material consisting of hydraulic cement, graded silica aggregates, special plasticizing and accelerating agents, which has been formulated for vertical or overhead use. It shall not contain chlorides, gypsums, plasters, iron particles, aluminum powder, or gas-forming agents or promote the corrosion of steel it may come into contact with. Set time (ASTM C-191) shall be less than 30 minutes. One-hour compressive strength (ASTM C-109) shall be a minimum of 200 psi and the ultimate compressive strengths (ASTM C-882-Modified) shall be a minimum of 1700 psi.
- D. Exterior Chemical Curtain Grouting and/or for Major Active Leaks (>0.5 gpm)
1. Exterior chemical curtain grouting shall be used to stop significant infiltration sources. Chemical curtain grouting shall be solvent-free, hydrophilic resin designed to seal leaks in concrete and masonry structures. When it contacts water, chemical grout shall expand exponentially and form a tough, flexible foam seal that cannot be penetrated by water. Chemical curtain grouting shall be manufactured by Avanti International, DeNeef Construction Chemicals, or approved equal.

2. Exterior chemical curtain grouting shall be applied according to manufacturer's recommendations and shall have the following minimum requirements:

Minimum Requirements		
Bond Strength	ASTM C882	60 psi
Tensile Strength	ASTM D3574 ASTM D1623, free rinse	310 psi 54 psi
Elongation	ASTM D3574 ASTM D1623, free rinse	280% 64%
Shrinkage	ASTM D1042/D756	< 2%
Internal Linear Shrinkage		5%
Tear Resistance	ASTM D3574	20 lbs/in
Density	ASTM D3574	30.8 lbs/ft ³

3. Cured properties will vary depending on job conditions. Cured properties above (ASTM D3574) are derived from 10-15 pcf foam. Free rise properties are derived from 3-5 pcf foam.
4. Exterior chemical curtain grouting shall be suitable for the intended purpose and shall be compatible with the monolithic lining as certified by the manufacturer.

2.2 LEVEL YELLOW

- A. Spray applied or centrifugally cast lightweight structural reinforced cement manhole lining:

1. The material applied to the surface of the manhole (similar to Strong Seal MS-2, Permacast CR-9000, or Quadex QM-1S) shall be a cementitious blend of acid resistant binders, silicious aggregates, non-metallic fibers and other additives for constructing a liner that is impervious to the flow of water, is resistant to sulfide attack, and restores structural integrity to existing manhole walls.
2. A monolithic liner shall be formed which covers all interior manhole surfaces and shall have the following minimum requirements at 28 days:
 - a. Compressive Strength (ASTM C-109) 9,000 psi
 - b. Tensile Strength (ASTM C-496) 600 psi
 - c. Flexural Strength (ASTM C-293) (Modified) 750 psi
 - d. Shrinkage (ASTM C-596) 0% @90%R.H.
 - e. Bond (ASTM C-882) 2,000 psi

f. Density, when applied 135± pcf

2.3 LEVEL BLUE

- A. Spray applied epoxy resin system manhole lining:
1. The material sprayed onto the surface of the manhole shall be an epoxy resin (similar to Raven 405, or Warren Environmental Systems M-201 and S-301) system formulated for application within a sanitary sewer environment. The resin will exhibit suitable corrosion resistance and enhance the structural integrity of the existing manhole.
 2. The cured epoxy resin system shall conform to the following minimum structural standards:

<u>DESCRIPTION</u>	<u>TEST METHOD</u>	<u>RESULTS</u>
Tensile Strength	ASTM D-638	7,000 psi
Flexural Strength	ASTM D-790	11,000 psi
Flexural Modulus	ASTM D-790	500,000 psi
Compressive Strength	ASTM D-695	12,000 psi

PART 3 - EXECUTION

3.1 REHABILITATION OF MANHOLE STRUCTURE

- A. General Procedures:
1. Safety: The Contractor shall perform all work in strict accordance with all applicable OSHA, TOSHA, and manufacturer's safety standards. Each method of manhole rehabilitation in this Section requires some degree of manhole entry by workers. Particular attention is drawn to those safety requirements regarding confined space entry and respiratory protection from airborne particulate materials during cleaning and product mixing and application.
 2. Cleaning: All concrete and masonry surfaces to be rehabilitated shall be clean. All grease, oil, laitance, coatings, loose bricks, mortar, unsound brick or concrete and other foreign materials shall be completely removed. Water blasting utilizing a 210° F steam unit and proper nozzles shall be the primary method of cleaning; however, other methods such as wet or dry sandblasting, acid wash, concrete cleaners, degreasers or mechanical means may be required to properly clean the surface. All surfaces on which these methods are used shall be thoroughly rinsed, scrubbed, and neutralized to remove cleaning agents and their reactant products. Debris resulting from cleaning shall be removed from the manhole and not allowed to be carried downstream.
 3. Stop Infiltration: After surface preparation and prior to the application of mortars and linings, infiltration shall be stopped.

This applies to defects within the manhole as well as any annular spaces between a host pipe and pipe liner. Water seepage shall be stopped with waterproof cement plug material or water activated polyurethane resins. Severe leaks which cannot be stopped with either of these two specified materials shall be reported to the Owner. If so directed by the Owner, then these severe leaks shall be stopped using chemical (urethane) grout injected through the manhole wall, the invert or the bench (as appropriate). Excess cured grout shall be completely removed from the inside surface before further patching or lining.

4. Patching: All large holes or voids around steps, joints or pipes, all spalled areas and all holes caused by missing or cracked brick shall be patched and all missing mortar repointed using a nonshrink patching mortar. All cracked or disintegrated material shall be removed from the area to be patched or repointed, exposing a sound subbase. All cracks not subject to movement and greater than 1/16 inch in width shall be routed out to a minimum width and depth of 1/2 inch and patched with nonshrink patching mortar.
5. Flow Control: The Contractor shall be responsible for plugging or diverting the flow of sewage as needed for repair and lining of manhole inverts and benches.
6. Remove all loose grout and rubble from existing channel. Work shall include aligning inflow and outflow ports in such a manner as to prevent the deposition of solids at the transition point. All inverts shall follow the grades of the pipe entering the manhole. Changes in direction of the sewer and entering branch or branches shall have a true curve of as large a radius as the size of the manhole will permit, but will be shaped to allow easy entrance of maintenance equipment including buckets, T.V. camera, etc.
7. Manhole steps: Inspect all manhole steps prior to rehabilitation. Report to the Engineer any steps which appear loose, deteriorated, broken, or otherwise unsafe.
8. Each system shall be installed in accordance with the manufacturer's recommendation to withstand groundwater pressures. For manholes greater than 12 feet in depth, the lining shall withstand the pressures associated with a groundwater depth equal to the manhole depth. Linings for all other manholes shall withstand the pressures associated with groundwater depth of 12 feet. Measure groundwater depth from manhole bench to top of ground surface.
9. Application of products shall be by factory certified applicators.

3.2 SPRAY APPLIED LIGHTWEIGHT STRUCTURAL REINFORCED CEMENT (Level "Yellow" and Level "Green")

- A. The surface prior to spraying shall be damp without noticeable free water droplets or running water. Materials shall be spray-applied to a minimum uniform thickness to insure that all cracks, crevices, and voids are filled and a somewhat smooth surface remains after light troweling. The light troweling is performed to compact the material into voids and to set the bond.
- B. The first application shall have begun to take an initial set (disappearance of surface sheen which could be 15 minutes to 1 hour depending upon ambient conditions) before the second application to assure a minimum total finished thickness of 1/2 inch. The final finished thickness may need to be greater than 1/2 inch as recommended by the manufacturer to withstand groundwater pressures. A depth gauge shall be used during application, at various locations, to verify the required thickness. The surface then shall be troweled to smooth finish with care taken not to over trowel so as to bring additional water to the surface and weaken it. Manufacturer's recommendations shall be followed whenever more than 24 hours have elapsed between applications.
- C. The bench covers used to catch debris shall be removed and the bench and invert sprayed such that a gradual slope is produced from the walls to the invert with the thickness at the edge of the invert being no less than 1/2 inch. The wall-bench intersection shall be rounded to a uniform radius the full circumference of the intersection.
- D. No application shall be made to frozen surfaces or if freezing is expected to occur within the manhole for 24 hours after application. If ambient temperatures are in excess of 95° F, precautions shall be taken to keep the mix temperature at time of application below 90° F, using ice if necessary.
- E. The final application shall have a minimum of four (4) hours cure time before being subjected to active flow.

3.3 CENTRIFUGALLY CAST STRUCTURAL REINFORCED CEMENT (Level “Yellow” and Level “Green”)

- A. The rotating casting applicator shall be positioned to evenly apply the material and be withdrawn at a rate to assure a final minimum thickness of 1/2-inch. The final finished thickness may need to be greater than 1/2-inch as recommended by the manufacturer to withstand groundwater pressures. A depth gauge shall be used during application, at various locations, to verify the required thickness.
- B. The bench covers used to catch debris shall be removed and the bench and invert sprayed or hand applied so that a gradual slope is produced from the walls to the invert with the thickness at the edge of the invert being no less

than 1/2-inch. The wall-bench intersection shall be rounded to a uniform radius the full circumference of the intersection.

- C. No application shall be made to frozen surfaces or if freezing is expected to occur within the manhole for 24 hours after application. If ambient temperatures are in excess of 95° F, precautions shall be taken to keep the mix temperature at time of application below 90° F.
- D. The final application shall have a minimum of one (1) hour cure time before being subjected to active flow.

3.4 SPRAYED APPLIED EPOXY RESIN SYSTEM (Level “Blue” and Level “Green”)

- A. The epoxy resin shall be sprayed onto the surfaces of the manhole walls, and the benches to produce a smooth coating and yield the required structural integrity and corrosion resistance. A depth gauge shall be used during application at various locations to verify the required thickness.
- B. The epoxy resin shall be applied to a minimum thickness of 0.125 inches at the top of the manhole and gradually thickened, in accordance with manufacturer's recommendations, to withstand groundwater pressures. The application shall have a minimum of three hours cure time before being subjected to active flow.
- C. The sloped surface of the manhole bench shall be made non-skid by broadcasting aluminum oxide or sand into the surface prior to gelatin/set.

3.5 MANHOLE REHABILITATION ACCEPTANCE

- A. Any visible leakage in the manhole or structure, before, during, or after the test shall be repaired regardless of any test results.
- B. Testing for Level “Yellow” and Level “Green” Rehabilitation (lightweight structural reinforced concrete).
 - 1. Two test cubes (2” cube specimens according to ASTM C 109/C) of the spray applied or centrifugally cast lightweight structural reinforced concrete material shall be taken randomly as directed by the inspector at contractors’s expense to verify strengths.
 - 2. Thickness shall be verified with a wet gage at any random point of the new interior surface. Any areas found to be thinner than the minimum specified thickness shall immediately receive additional material.
- C. Testing for Level “Blue” and Level “Green” Rehabilitation (epoxy coating).

1. During application a wet film thickness gauge, meeting ASTM D4414 - Standard Practice for Measurement of Wet Film Thickness of Organic Coatings by Notched Gages, shall be used. Measurements shall be taken, documented and attested to by Contractor for submission to Owner.
2. After the coating product(s) have set in accordance with manufacturer instructions, all surfaces shall be inspected for holidays with high-voltage holiday detection equipment. Reference NACE RPO 188-99 for performing holiday detection. All detected holidays shall be marked and repaired by abrading the coating surface with grit disk paper or other hand tooling method. After abrading and cleaning, additional coating can be hand applied to the repair area. All touch-up/repair procedures shall follow the coating manufacturer's recommendations. Documentation on areas tested, results and repairs made shall be provided to Owner by Contractor.

END OF SECTION

SECTION 4.07

FLOW CONTROL OF SEWER LINES

PART 1 - GENERAL

1.01 DESCRIPTION

- A. This Section includes all materials, labor, and equipment required to provide bypass flow control for sanitary sewer lines construction, upgrade, or rehabilitation.
- B. Also, furnish all power, maintenance, etc. to implement the bypass flow control and diversion pumping to divert the existing flow around the work area for the work's duration. If the duration of the work coincides with conditions that have a potential to cause higher flows than the minimum, the contractor shall be at risk for containing all flows.
- C. The design, installation, and operation for the temporary bypass pumping system shall be solely the Contractor's responsibility. The Contractor is to plan and perform his construction work for the supporting diversion pumping operations to reduce risk, avert overflows, minimize exposure durations and address variable season and event sewer flow rates.

1.02 PERFORMANCE AND PENALTIES

- A. The Contractor shall ensure:
 - 1. All temporary sewer bypass pumping activities for the work are completed in full compliance with the local Stormwater Management Regulations, and no water quality or quantity compliance issues are encountered.
 - 2. No illicit pollutant discharges to (or to a location that would create contaminated water runoff to) a storm sewer, a stormwater conveyance, or a water body within Town of Chapel Hill shall occur.
 - 3. All temporary sewer bypass pumping activities for the work are completed in full compliance with the Tennessee Department of Environment and Conservation and the U.S. EPA regulations, and no water quality or quantity compliance issues are encountered.
- B. No discharge of sewage or debris shall be released to the environment. Should the Contractor's actions cause a sewage or debris overflow or bypass to the environment, site cleanup will be the Contractor's responsibility consistent with the Town of Chapel Hill *CMOM Response Plan for Overflows* and regulators directions. All overflow or bypass environmental cleanup activities shall be immediately commenced and prosecuted continuously by the Contractor. Any associated fines or penalties enacted by the Tennessee Department of Environment and Conservation, the U.S. EPA, and/or any other regulatory groups or programs will be borne solely by the Contractor.

1.03 SUBMITTALS

- A. At least 4 weeks prior to commencing work including plugging any line, bypass pumping, or similar actions, the Contractor shall submit to the Town of Chapel Hill, a

detailed *Bypass Sewage Pumping Plan* (Plan), as further described in these specifications, for review and approval. Any Plan approval does not relieve the Contractor from any responsibility for the Plan's adequacy or proper execution. The Contractor is responsible for conducting his work in a manner which will not cause overflows or system backups that could damage private and/or public property.

B. Submit the following in accordance with Section 2.04.

1. *Bypass Sewage Pumping Plan*. Plan shall contain, at minimum, the following:
 - a. Staging areas for pumps
 - b. Sewer plugging method and plug types
 - c. Size and location for manholes or access points for suction and discharge hose or piping
 - d. Size for pipeline or conveyance system to be bypassed
 - e. Number, size, material, location, and method for installing suction piping
 - f. Number, size, material, location, and method for installing discharge piping
 - g. Provide bypass pump sizes, capacity, number of each size to be on site, and power requirements. Pump sizing shall clearly indicate compliance with requirements in this Section.
 - h. Calculations for static lift, friction losses, and flow velocity (pump curves showing pump operating range)
 - i. Standby power generator size and location (if electric pumps are employed)
 - j. Downstream discharge plan
 - k. Method to protect discharge manholes or structures from erosion and damage
 - l. Thrust and restraint block sizes and locations
 - m. Noise control method for each pump and/or generator
 - n. Any temporary pipe supports and anchoring required
 - o. Plans for access to bypass pumping locations indicated on the Drawings
 - p. Schedule for installing and maintaining bypass pumping lines
 - q. Plan indicating routing for bypass pumping line locations
 - r. Plan indicating monitoring location selections
 - s. All items related to testing, inspection, maintenance, and monitoring as described in this Section

- t. All other incidental items necessary and/or required to ensure facilities are properly protected including protecting the access and bypass pumping locations from damage due to the discharge flows and compliance with the requirements and permit conditions specified in the Contract Documents
- u. For sewer rehabilitation by lining methods, generic plans may be developed for typical situations and various sizes to be implemented.

PART 2 - PRODUCTS

2.01 BYPASS EQUIPMENT

- A. All equipment used for bypass pumping shall be specifically designed for that intended purpose. All piping, pumps, etc. in contact with sanitary sewage shall be manufactured with materials designed for use in a sewage environment.
- B. All pumps used shall be fully automatic self-priming units which do not require foot valves or vacuum pumps in the priming system.
- C. The pumps shall be electric, hydraulic, or diesel powered.
- D. All pumps used shall be constructed to allow dry running for long periods of time in order to accommodate effluent flows' diurnal nature.
- E. Above-ground pumps and/or power units shall be located inside a temporary portable berm to contain any fuel or sewage that may spill during the normal course of operation.
- F. Hard discharge piping shall be butt-welded HDPE with a minimum pressure rating of 1.5 times the total dynamic pump head.
- G. Under no circumstances will irrigation type piping or glued PVC pipe be allowed.
- H. A discharge hose may be allowed on rehabilitation projects for short-term setups (less than or equal to 48 hours) on short sections with approval from the Town of Chapel Hill. Hoses shall have no leaks, and all couplings shall be quick connecting with gaskets.
- I. A multiple pump header system shall have check valves to facilitate pump removal, service, and/or replacement while the system remains operational.
- J. All above ground pumps and/or power units shall be equipped with sound attenuation measures which reduce noise levels to 75-decibels maximum at a 30-foot distance from the equipment during all operation periods. If equipment is operated between 8:00 PM and 6:00 AM, this equipment shall also be provided with a sound attenuation 3-sided enclosure including a roof.
- K. The discharge location (the point where the bypass main reenters the gravity sewer system) shall be constructed with adequate sealant materials to minimize sewer gas and odor release to the maximum extent possible.

PART 3 - EXECUTION

3.01 GENERAL REQUIREMENTS

- A. Provide bypass sewage pumping, as required, around the section in which work is to be performed. Bypass pumping shall be the Contractor's full responsibility. The bypass system shall be of sufficient capacity to handle a minimum of 2.0 times the dry weather daily peak flow of the pipeline section being bypassed. Performance of extended pumping durations in or immediately following precipitation events and/or with precipitation events in the forecast will require greater pumping system capacities to accommodate the potential higher flows.
- B. At least 4 weeks prior to the desired start date of construction requiring bypass pumping, submit a detailed description of the method proposed for bypass pumping to the Town of Chapel Hill for review and approval. The description shall include capacity calculations, operational conditions, conditions of performance relative to precipitation and antecedent conditions, all materials and equipment to be used, personnel, spare equipment, and sketches showing proposed pump-around setups. No work shall commence until the Town of Chapel Hill approves.
- C. Bypass pumping equipment shall include pumps, conduits, engines, and related equipment necessary to divert sewage flow around the section in which work is to be performed. Backup pumps shall be online and isolated from the primary system by valves. Include 100% mechanical redundancy installed online with a float or ultrasonic type system to switch to the standby system automatically if the primary system fails.
- D. Piping redundancy may be required for relatively long bypass piping lengths or large diameter bypass pipes as deemed necessary by the Town of Chapel Hill.
- E. Suction and discharge points shall only be located at manholes.
- F. If at any time the Contractor is unable to properly bypass pump the sewage, construction will be stopped until the Contractor can continue work in an acceptable manner. Additional contract time for delays caused by improper equipment, labor, or breakdowns will not be considered.
- G. Service shall be maintained at all times. Surcharges due to plugging the sewer line for bypass pumping shall be maintained to prevent service backups and overflows anywhere in the system.
- H. For rehabilitation projects and only with the Town of Chapel Hill's approval, a hose may be used for 48 hours or less. If the anticipated bypass time exceeds 48 hours, use hard piping only. If using a hose when the bypass time reaches 48 hours, the Contractor may either install hard piping to accomplish the bypass or restore flow until an approved bypass method can be employed. No modifications to the bypass system shall be made without Town of Chapel Hill's approval.
- I. The bypass or diversion pumping system shall be able to pump all of the sewage in the existing line regardless of the performance period's weather and seasonal conditions. All pumping equipment to be used shall be submitted to the Town of Chapel Hill for review and approval.
- J. Bypass pumping systems are required to be operated and continuously monitored 24-hours per day for flow diversion.

- K. The bypass pumping must be initiated at one manhole upstream and continue to one manhole downstream of the line being rehabilitated in order to use flow-through plugs at the insertion and end points. The liner bag may not be used as part of the bypass pumping system or as a plug in the line.
- L. The temporary diversion pumping system shall be placed in operation prior to the commencement of work in the areas being bypassed. Minimum times of operation prior to the commencement of work are 1 hour for small diameter CIPP lining and 4 hours for any other major system work such as trunk sewer diversion, large diameter sewer lining, or pumping station work.
- M. Provide the necessary stop/start controls and a visual alarm indicating a pump malfunction for each pump.

3.02 PERFORMANCE REQUIREMENTS

- A. It is essential for the operation of the existing system being bypassed that no interruptions in the flow occur throughout the project's duration. Provide, maintain, and operate all temporary facilities such as dams, plugs, pumping equipment (primary and backup units as required), conduits, all necessary power, and all other labor and equipment necessary to intercept the incoming flow before it reaches the point where it would interfere with the work, carry it past the work area, and return it to the existing system downstream of the work.
- B. The temporary pumping system's design, installation, and operation shall be the Contractor's responsibility. The bypass system shall meet all codes and requirements for regulatory agencies having jurisdiction.
- C. The temporary pumping system's design, installation, and operation shall address system flow variations for diurnal peaks and low flows during the pumping period.
- D. Provide all necessary means to safely convey the sewage past the work area. The Contractor will not be permitted to stop or impede the sewer main flows under any circumstances.
- E. No flow diversion around the work area shall be performed in a manner that will cause damage to or the surcharging of the Town of Chapel Hill system. The diversion shall protect public and private property from damage and flooding.
- F. Protect water resources, wetlands, and other natural resources.

3.03 FIELD QUALITY CONTROL AND MAINTENANCE

- A. Testing: Prior to actual operation, test the bypass pumping discharge hard piping system for leaks and pressure using clean water. Bypass hard piping shall be hydrostatically tested following each setup and prior to flow diversion or bypass to a minimum pressure 1.5 times the pump(s) total dynamic head. The Town of Chapel Hill shall be given a 24-hour notice prior to testing.
- B. Inspection: Inspect the bypass pumping system on a continuous basis to ensure the system is working properly. A daily checklist for physically inspecting the piping shall be required. The checklist shall contain all bypass pumping system components and shall be specifically developed to address aspects for the individual project.

- C. Maintenance Service: Ensure that the temporary bypass pumping system is properly maintained and that a responsible operator shall be readily available at all times when pumps are operating.
- D. Monitoring
 - 1. During bypass pumping, continuously monitor all bypass pumping system components.
 - 2. A telemetry system or designated personnel to maintain 24-hour onsite monitoring shall be required to alert the Contractor to system malfunctions or high liquid levels in manholes.
 - 3. If bypass pumping activities are conducted near State waters or in other situations where the potential exists for a sewage release to potentially enter State waters by other than direct means, an in-line stream monitoring system shall be used to measure real-time conductivity and dissolved oxygen (DO) concentrations in 30-minute intervals at a minimum. The system shall be mounted in the receiving stream in the immediate downstream area(s) adjacent to the location(s) of the bypass piping system discharge to the gravity conveyance system. The system shall have web-portal capabilities with alarm functions for conductivity and DO. The alarm function shall be equipped with battery power and solar charging provisions and shall be able to send e-mail and text messaging alarms to at least five devices.
- E. Additional Materials
 - 1. Spare parts for pumps and piping shall be kept on site as required.
 - 2. Repair kits for piping shall be kept on site as required.
- F. Installation and Removal
 - 1. Remove manhole sections or make connections to the existing conveyance system. Construct temporary bypass pumping structures only at the access location(s) indicated on the Drawings and as may be required with Town of Chapel Hill's approval to provide adequate suction conduit.
 - 2. Plugging or blocking flows shall incorporate a primary or secondary plugging device. When plugging or blocking is no longer needed for work performance and acceptance, it is to be removed in a manner that permits the sewage flow to slowly return to normal without surge flows to prevent surcharging or causing other major disturbances downstream.
 - 3. When working inside manholes, sewers, or force mains, exercise caution and comply with all applicable OSHA requirements.
 - 4. When the bypass pipeline crosses local streets and private driveways, place the bypass pipelines in trenches and cover with temporary pavement or other protected means of pipe crossing. Obtain any property owner approvals for placing the temporary pipeline.

3.04 CLEANUP

- A. Upon acceptance of the installation work and testing, restore the project area affected by the operations to a condition at least equal to that existing prior to the work.

END OF SECTION

SECTION 5.01

WATER LINES

PART 1 GENERAL

1.01 SECTION INCLUDES

- A. All contractors installing water mains in any way related to the waters of the Town of Chapel Hill, must be a licensed General Contractor in the State of Tennessee if the value of the water line installation exceeds \$25,000. Refer to Section 1.00 for applicable license classifications. Work performed by any person or company not possessing the proper license will not be accepted into service for water distribution into the Town of Chapel Hill.
- B. Contractor shall be responsible for safely storing materials needed for work that have been accepted by him until they have been incorporated into the completed project. Keep the interiors of all pipes, fittings, and other accessories free from dirt and foreign matter at all times.
- C. Trenching includes excavating, backfilling, compacting, disposing of surplus material, and all other work incidental to the construction of trenches for utilities and buried appurtenances, including additional excavation which may be required for structures forming a part of the pipe line.
- D. Excavation includes removal of quicksand, hardpan, boulders, rock, clay, rubbish, unforeseen obstacles, underground conduits, pipe, drain tile, trees, root, timber or masonry structures, pavements, sidewalks, and all other obstacles encountered. No claim for additional payment will be accepted because of the character of the ground in which the excavation is made. Excavation will be unclassified with no separate payment for rock excavation.
- E. Reaction blocking and joint restraint devices are required at all fittings. Where soil is not suitable to provide stability for reaction blocking or where site condition constraints do not allow physical space for reaction blocking, all fittings, appurtenances and valves must still be restrained with restraint devices. Restraint devices shall be Romac GripRing pipe restraint system or approved equal.

1.02 RELATED SECTIONS

- A. Section 1.00 General Requirements and Design Criteria
- B. Section 3.08 Trenching, Backfilling and Compaction for Utilities
- C. Section 3.06 Unclassified Excavation for Utilities
- D. Section 5.02 Valves Hydrants and Blowoffs

PART 2 PRODUCTS

2.01 MATERIALS

- A. Bedding and backfill material shall be size No. 67 in accordance with the Tennessee Department of Transportation's Standard Specifications for Road and Bridge Construction or satisfactory soil materials of clay, rock or gravel, free of debris, waste, frozen materials, vegetative and other deleterious matter that has a size of no more than 2" as specified herein and/or as shown on the plans.
- B. Portland cement, ASTM C150, Type I.
- C. Steel bar reinforcing, ASTM A615, Grade 60.
- D. Concrete aggregate, ASTM C33.

2.02 DUCTILE IRON PIPE AND FITTINGS

- A. Ductile cast iron pipe shall be made of good quality ductile iron that meets the requirements for modular iron castings of ASTM E8. It shall be plain end ductile iron pipe with push-on, single gasket joints. The design thickness shall be that specified by ANSI A21.50/AWWA C150, except that all pipe with a diameter of 12-inch or less shall have a wall thickness of pressure class 350. Pipe 12-inch and greater shall be wall thickness pressure class 250.
- B. Ductile iron pipe shall be centrifugally cast in metal or sand-lined molds and shall conform to the specifications of ANSI A21.51/AWWA C151. It shall be made and tested in accordance with ASTM A339 and shall be subjected to and able to withstand a hydrostatic pressure of 500 psi. The maximum depth of pits shall be half that allowed in the AWWA specifications.
- C. The length of each individual piece of ductile iron pipe shipped must be plainly marked on that piece of pipe.
- D. The push-on, single gasket joints shall be either Fastite (manufactured by American Cast Iron Pipe Company), Tyton (U. S. Pipe and Foundry Company), Super Bell-Tite (Clow Corporation), or other joints of similar type and equal quality. They shall be able to withstand 200 psi of operating pressure.

- E. The bell of each pipe shall have a tapered annular opening and a cast or machined retaining groove for the gasket. The gasket groove shall have a flared design so that maximum deflection will be provided. The plain spigot end of the pipe shall be beveled in order to simplify its entry into and centering within the bell and the compression of the gasket.
- F. The gasket shall be of high-quality vulcanized rubber made in the form of a solid ring to exact dimensions. The design of the gasket groove in the bell of the pipe and the design, hardness, and other properties of the gasket itself shall be such that the joint is liquid tight for all pressures from a vacuum to a maximum rating of 350 psi of internal liquid pressure.
- G. Enough lubricant shall be furnished with each order to provide a thin coat on the spigot end of each pipe. This lubricant shall be nontoxic, impart no taste or smell to the water, and have no harmful effect on the rubber gasket. It shall have a consistency that will allow it to be easily applied to the pipe in either hot or cold weather and that will enable it to adhere to either wet or dry pipe.
- H. Fittings shall be ductile iron. Use compact mechanical joint fittings (4"-12"). All fittings shall conform to the specifications of ANSI A21.53/AWWA C153 as manufactured by American Cast Iron Pipe Company, U. S. Pipe and Foundry Company, Union Tyler, Griffin or approved equal. All fittings for ductile iron pipe shall be restrained using Romac GripRing pipe restraint system or approved equal.
- I. Pipe and fitting shall be lined with enameline or a thin cement lining as specified in ANSI A21.4/AWWA C104. In addition, a bituminous seal coat or asphalt emulsion spray coat approximately one (1) mil thick shall be applied to the cement lining in accordance with the pipe manufacturer's standard practices.
- J. Restrained push-on joint pipe and fittings when required by the Town of Chapel Hill **shall** be "TR Flex" by U. S. Pipe and Foundry Company, "Super-Lock" by Clow Corporation, Flex Ring ® by America Cast Iron Pipe Co., or approved equal.
- K. When required by the Town of Chapel Hill, restrained joint pipe may be accomplished by the use of gripper-style restraint gaskets. Gripper style restraint gaskets shall be Fast-Grip® by American Cast Iron Pipe Co., Field-Lok 350® by US Pipe Co., Sure Stop 350® by McWane Pipe Co., Talon™ RJ Gasket by Griffin Pipe Co. or approved equal.
- L. The pipe manufacturer shall furnish the Town of Chapel Hill a certificate of inspection, sworn to by the factory inspector in the presence of a notary

public, stating that the pieces of pipe in the shipment were made and tested in accordance with ANSI A21.51 and that they were subjected to and withstood a hydrostatic pressure of 500 psi. Each statement is to give the number of pieces of pipe in the shipment, the length of each piece of pipe, and the serial number of each piece of pipe making up the shipment. In addition, the weight of each individual piece of pipe making up the shipments to be listed opposite the serial number of each pipe length and attached to the certificate of inspection.

2.03 PVC PIPE AND FITTINGS - SDR IPS PRESSURE PIPE & AWWA C900 PIPE

- A. All plastic pipe shall be made from Class 12454-B polyvinyl chloride (PVC 1120) as defined by ASTM D1784.
- B. PVC pipe type shall be as noted on the plans or as directed by the Owner.
- C. SDR pipe Class 200 or Class 250 pipe shall have NSF approval and be manufactured in accordance with ASTM D2241. Pipe shall include integral bell and spigot joints with elastomer gaskets for the conveyance of water. The following tests shall be run for each size and type of piping being produced, as specified below:
 - 1. Flattening Test: once per shift in accordance with ASTM D2412. Upon completion of the test, the specimen shall not be split, cracked, or broken.
 - 2. Acetone Test (Extrusion Quality Test): once per shift in accordance with ASTM D2152. There shall be no flaking, peeling, cracking, or visible deterioration on the inside or outside surface after completion of the test.
 - 3. Quick Burst Test: once per 24 hours in accordance with ASTM D1599.

<u>SDR</u>	<u>Pressure Rating</u>	<u>Minimum Bursting Pressure, psi</u>
21	200	630
17	250	800

- 4. Impact Tests: For six (6) inches and larger, once per shift in accordance with ASTM D2444; for four (4) inches and smaller, once each two (2) hours in accordance with ASTM D2444.
- 5. Wall Thickness and Outside Dimensions Tests: once per hour in accordance with ASTM D2122.

6. Bell Dimension Test: once per hour in accordance with ASTM D3139.

D. If any specimen fails to meet any of the above-mentioned tests, all pipe of that size and type manufactured between the test periods must be scrapped and a full set of tests rerun.

E. AWWA C900 PVC pipe shall meet the requirements of AWWA C900 and be for 4-inch through 12-inch pipe, C.I.O.D. in blue color with integral bell and spigot joints and elastomer gaskets.

F. Standard laying lengths for C900 pipe shall be 20 feet for all sizes. Color of pipe shall be blue.

	<u>DR</u>	<u>Pressure Rating</u>	<u>Minimum Burst Pressure, psi</u>
G.	18	235	755
	14	305	985

D. Furnish a certificate from the pipe manufacturer stating that he is fully competent to manufacture PVC pipe of uniform texture and strength and in full compliance with these specifications and further stating that he has manufactured such pipe and done so in sufficient quantities to be certain that it will meet all normal field conditions. In addition, the manufacturer's equipment and quality control facilities must be adequate to ensure that each extrusion of pipe is uniform in texture, dimension, and strength. Also furnish a certificate from the manufacturer certifying that the pipe furnished for this project meets the requirements of these specifications.

E. All pipe shall be manufactured in the United States of America. All pipe for any one project shall be made by the same manufacturer.

F. All four (4) inch and six (6) inch pipe may be furnished in the manufacturer's standard laying lengths of 20 feet, 38 feet, or 40 feet. Pipe eight (8) inches and larger shall be furnished in 20 feet lengths. The Contractor's methods of storing and handling the pipe shall be approved by the Engineer. All pipe shall be supported within five (5) feet of each end; in between the end supports, there shall be additional supports at least every 15 feet. The pipe shall be stored away from heat or direct sunlight.

G. Certain information shall be applied to each piece of pipe. At the least, this shall consist of:

1. Nominal size
2. Type of material
3. SDR/DR

4. Manufacturer
 5. NSF Seal of Approval
 6. Pressure Class
- H. Pipe that fails to comply with the requirements set forth in these specifications shall be rejected.
- I. The pipe shall have push-on joints designed with grooves in which continuous molded rubber ring gaskets can be placed. Gaskets shall be made of vulcanized natural or synthetic rubber; no reclaimed rubber will be allowed. Gasket materials shall meet the requirements of ASTM F477. The gaskets shall be of the manufacturer's standard design dimensions and of such size and shape as to provide a positive seal under all combinations of joint and gasket tolerance. The gasket and annular groove shall be designed and shaped so that when the joint is assembled, the gasket will be radially compressed to the pipe and locked in place against displacement, thus forming a positive seal.
- J. The spigot end of each pipe shall be beveled so that it can be easily inserted into the gasket joint, which in turn shall be designed so that the spigot end may move in the socket as the pipe expands or contracts. The spigot end shall be striped to indicate the distance into which it is to be inserted into the socket. Each joint shall be able to accommodate the thermal expansions and contractions experienced with a temperature shift of at least 75 degrees F.
- K. Enough lubricant shall be furnished with each order to provide a coat on the spigot end of each pipe. This lubricant shall be nontoxic, impart no taste or smell to the water, have no harmful effect on the gasket or pipe material, and support or promote any bacterial growth. The lubricant containers shall be labeled with the manufacturer's name.
- L. Joints shall be manufactured in accordance with ASTM D3139 except that the thickness of the bell shall be, as a minimum, equal to that of the barrel. Joints shall be either integral bell or ring joints with rubber compression gaskets as manufactured by the Vulcan Plastic Corporation or equal. However, the pipe and bell must be made by the same manufacturer.
- M. Fittings shall be ductile iron. Use standard mechanical joint fittings. All fittings shall conform to the specifications of ANSI A21.53/AWWA C153. The gaskets shall be ducked tipped transition gaskets for use with PVC pipe.
- N. Fittings shall be lined with enameline or a thin cement lining as specified in ANSI A21.4/AWWA C104. In addition, a bituminous seal coat or asphalt emulsion spray coat approximately one (1) mil thick shall be

applied to the cement lining in accordance with the pipe manufacturer's standard practices.

- O. Fittings shall be in accordance with the compact mechanical joint fittings manufactured by the U.S. Pipe and Foundry Company, American Cast Iron Pipe Company, Clow Corporation, McWane Co. or equal.
- P. All fittings for PVC pipe shall be restrained using Romac GripRing pipe restraint system or approved equal.

2.04 HIGH DENSITY POLYETHYLENE (HDPE) PIPE AND FITTINGS

- A. Materials used for the manufacturer of polyethylene pipe and fittings shall be PE4710 high density polyethylene meeting cell classification 345464C per ASTM D3350; and meeting Type III, Class B or Class C, Category 5, Grade P34 per ASTM D1248; and shall be listed in the name of the pipe and fitting Manufacturer in PPI TR-4, Recommended Hydrostatic Strengths and Design Stresses for Thermoplastic Pipe and Fittings Compounds, with a standard grade rating of 1600 psi at 73°F per ASTM D-2837. The Manufacturer shall certify that the materials used to manufacture pipe and fittings meet these requirements.
- B. HDPE Pipe shall conform to AWWA C906, DR-9, Ductile Iron Pipe (DIP) size and NSF 61 Standard. Polyethylene pipe shall be manufactured in accordance with ASTM F714, Polyethylene (PE) Plastic Pipe (SDR-PR) Based on Controlled Outside Diameter and shall be so marked. Each production lot of pipe shall be tested for (from material or pipe) melt index, density, % carbon, dimensions and either quick burst or ring tensile strength (equipment permitting).
- C. Service Identification:
Permanent identification of piping service shall be provided by co-extruding multiple equally spaced color stripes into the pipe outside surface or by solid colored pipe shell. The striping material shall be the same material as the pipe material except for color. The color BLUE shall be used to identify pipe for potable water use.
- D. Polyethylene Fittings and Custom Fabrication:
Polyethylene fittings and custom fabrications shall be molded or fabricated by the pipe manufacturer or trained personnel. Butt fusion outlets shall be made to the same outside diameter, wall thickness, and tolerances as the mating pipe. All fittings and custom fabrications shall be fully rated for the same internal pressure as the mating pipe. Fabricated fittings must have the same working pressure as the mating pipe.
- E. Molded Fittings:

Molded fittings shall be manufactured in accordance with ASTM D3261, Butt Heat Fusion Polyethylene (PE) Plastic Fittings for Polyethylene (PE) Plastic Pipe and Tubing, and shall be so marked. Each production lot of molded fittings shall be subjected to the test required under ASTM D3261.

- F. **Fabricated Fittings:**
Fabricated fittings shall be made by heat fusion joining specially machined shapes cut from pipe, polyethylene sheet stock, or molded fittings. Fabricated fittings shall be rated for internal pressure service equivalent to the full service pressure rating of the mating pipe. Directional fittings 16" and larger such as elbows, tees, crosses, etc., shall have a plain end inlet for butt fusion and flanged directional outlets.
- G. **Polyethylene Flange Adapters:**
Flange adapter shall be made with sufficient through-bore length to be clamped in a butt fusion joining machine without the use of a stub-end holder. The sealing surface of the flange adapter shall be machined with a series of small v-shaped grooves to provide gasketless sealing, or to restrain the gasket against blow-out. Below ground flange adapters may only be utilized when specified and when MJ adapters are not commercially available in the required size. Adapters for 30 inch and smaller pipe shall utilize an MJ adapter (see below).
- H. **Back-up Rings and Flange Bolts:**
Flange adapters shall be fitted with lap joint flanges pressure rated equal to or greater than the mating pipe. Convolute style backup rings preferred over the flat stock rings. The lap joint flange bore shall be chamfered to provide clearance to the flange adapter radius. Flange bolts and nuts shall be Grade 2 or higher.
- I. **Manufacturer's Quality Control:**
The pipe and fitting manufacturer shall have an established quality control program responsible for inspecting incoming and outgoing materials. Incoming polyethylene materials shall be inspected for density, melt flow rate, and contamination. The cell classification properties of the material shall be certified by the supplier, and verified by Manufacturer's Quality Control.
- J. **Polyethylene Mechanical Joint (MJ) Adapters:**
Mechanical connections of HDPE pipe (4" and larger) to Ductile Iron or PVC piping, mechanical joint fittings, or valves shall be through a self-restraining, fusible mechanical joint adapter with or without an integral, internal stainless steel insert. Mechanical joint adapter shall be of the same SDR rating as the pipe. A separate, loose stainless steel type insert will only be allowed for pipe sizes 4 inch through 8 inches. Provide the mechanical joint adapter, including but not limited to longer tee bolts or

all thread rods with nuts at the mechanical joint bell. Note that PE flanged adapters may only be utilized for pipe sizes where MJ adapters are not commercially available.

- K. Cast Transition Couplings:
HDPE to MJ cast transition coupling may only be utilized for 8 inch and smaller pipe size. A stainless steel stiffener is required sized at proper ID of HDPE pipe. The transition coupling must be epoxy lined (3 mils minimum for water use and 12 mils minimum for sewer use). Acceptable is a Power Seal model 3520 or approved equal.
- L. Electro fusion Couplings and Fittings:
Electro fusion joining procedures shall not be used in any location or application on this project.
- M. Drilling Fluids shall be a bentonite slurry.

2.04 PLAIN END TO PLAIN END RESTRAINT DEVICE

- A. Joint restraint to prevent axial separation shall be incorporated into the design of the sleeve or coupling used to connect two plain ends of same or dissimilar materials, such as ductile iron pipe, steel pipe, PVC pipe (C900, C905, or ASTM D2241) and/or high density polyethylene (HDPE) pipe.
- B. To prevent movement causing fitting to slide or rotate, internal pipe wall stiffeners must be used. The stiffeners must be sized to encompass the entire bearing length of the restraint devices.
- C. Restraint devices shall consist of multiple gripping wedges incorporated into a follower gland. Restraint device shall have torque limiting twist-off nuts.
- D. The coupling sleeve internal surfaces (wetted parts) shall be coated internally with a minimum of 15mils of fusion bonded epoxy conforming to the applicable requirements of ANSI/AWWA C213.
- E. Ductile Iron components shall meet or exceed the requirements of ASTM A536.
- F. The restraint joining system shall meet the applicable requirements of AWWA C219, ANSI/AWWA C111/A21.11, and ASTM D2000.
- G. The restraint coupling system shall be EBBA Iron, Inc. Series 3800, or approved equal.

2.05 WATER LINE DETECTION

- A. All non-metallic water lines shall have detection wire installed. Detection Wire shall be UL approved, 14 AWG, type THHN solid copper. The wire shall be color coded blue in accordance with APWA National Color Code. Adequate wire shall be terminated outside valve boxes for connection to line detection equipment. Where two sections of wire connect a 12 inch minimum twisted overlap is required with adequate bare wire connection for continuity. At uncased road crossings the Contractor shall install the copper wire onto the top of the water line. Where transition is made between ductile iron and plastic water line, the wire shall run continuous.
- B. All water lines shall have detectable tape installed above the pipe approximately 6"-10" below final grade. Detectable tape shall have a thickness of 5 mils, be manufactured using a 0.8 mil clear virgin polypropylene film, reverse printed and laminated to a 0.35 mil solid aluminum foil core, and then laminated to a 3.75 mil clear virgin polyethylene film. The tape shall be color coded blue in accordance with the APWA National Color Code and permanently imprinted with "Caution Buried Water Line Below".

2.06 UNDERGROUND UTILITY NOTIFICATION

- A. Prior to any digging for work pertaining to the Town of Chapel Hill , the Contractor must contact the underground utility notification center for the State of Tennessee to request that underground facilities be located and marked. Call 811 before digging commences.

PART 3 EXECUTION

3.01 EXCAVATION FOR PIPELINE TRENCHES

- A. Excavation for pipelines shall consist of the excavation necessary for the construction of water lines and their appurtenances (including valves, fittings, collars, concrete saddles, and pipe protection) that are called for by the drawings. It shall include clearing and grubbing where necessary, backfilling and tamping pipe trenches and around structures, and disposing of waste materials, all of which shall conform to the applicable provision set forth elsewhere in these specifications.
- B. The Contractor may, if he chooses, use a motor powered trenching machine. If he does, however, he shall be fully responsible for the preservation or repair of existing utility service connections.
- C. Unless the construction of lines by tunneling, jacking, or boring is called for by the drawings or specifically authorized by the Engineer, make

excavation for pipelines in open cut and true to the lines and grades shown on the drawings or established by the Engineer on the ground. Cut the banks of trenches between vertical parallel planes equidistant from the pipe centerline. The horizontal distance between the vertical planes (of, if sheeting is used, between the inside faces of that sheeting) shall vary with the size of the pipe to be installed, but shall not be more than the distance determined by the following formula: $4/3d + 15$ ", where "d" represents the internal diameter of the pipe in inches. When approved in writing by the Engineer, the banks of trenches from the ground surface down to a depth not closer than 1' above the top of the pipe may be excavated to non-vertical and non-parallel plans, provided the excavation below that depth is made with vertical and parallel sides equidistant from the pipe centerline in accordance with the formula given above. Any cut made in excess of the formula $4/3d + 15$ " shall be at expense of the Contractor and may be cause for the Engineer to require that stronger pipe and/or a higher class of bedding be used at no cost to the Town of Chapel Hill.

- D. For all pipe in non-rock trenches, shape the bottom of all trenches to provide uniform bearing for the bottom of the pipe barrel.
- E. Excavate bell holes for bell and spigot pipe at proper intervals so that the barrel of the pipe will rest for its entire length upon the bottom of the trench. Bell holes shall be large enough to permit proper jointing of the pipe. Do not excavate bell holes more than 2 joints ahead of pipe laying.
- F. Do not excavate pipe trenches more than 200' ahead of the pipe laying, and not more than two hundred (200) feet of open ditch shall be left behind the pipe laying, and perform all work so as to cause the least possible inconvenience to the public. Construct temporary bridges or crossings when and where the Engineer deems necessary to maintain vehicular or pedestrian traffic.
- G. In all cases where materials are deposited along open trenches, place them so that in the event of rain no damage will result to the work and/or to adjacent property.
- H. Refer to Section 3.06, Unclassified Excavation for Utilities, paragraph 3.06, for sheeting, shoring and bracing requirements.

3.02 INSTALLATION OF WATER LINES

- A. Lay water lines to and maintain at the lines and grades required by the drawings. All fittings, valves, and hydrants shall be at the required locations, the spigots centered in the bells, and all valves and hydrant stems plumb.

- B. Unless otherwise indicated by the drawings, all water pipes shall have at least 30 inches of cover. Ductile iron pipe shall be required when installed under sidewalks, storm drains, roadways and paved areas. Where these transitions occur between PVC and ductile iron pipe, the detector wire shall be continuous where ductile iron pipe is required for crossings. No departure from this policy shall be made except with the approval of the Town of Chapel Hill.
- C. Provide and use tools and facilities that are satisfactory to the Town of Chapel Hill and that will allow work to be done in a safe and convenient manner. All pipe, fittings, valves, and hydrants are to be unloaded from the trucks using suitable tools and equipment. Use a derrick, ropes, or other suitable tools or equipment to lower all pipe, fittings, valves, and hydrants into the trench one (1) piece at a time. Lower each piece carefully so that neither it nor any protective coating or lining it may have shall be damaged. Under no circumstances drop or dump water line materials into the trench.
- D. Any pipes strung out along the route of the proposed lines before the actual installation of those lines is due to take place shall not be lowered into the trench until they have been swabbed to remove any mud, debris, etc., that may have accumulated within them. PVC pipe shall be strung out a maximum of one (1) day ahead of pipe laying. Remove all unnecessary material from the bell and spigot end of each pipe. Before any pipe is laid, brush and wipe clean the outside of its spigot end and the inside of its bell, and leave dry and oil-free.
- E. Take every precaution to keep foreign material from getting into the pipe while it is being placed in the line. If the crew laying the pipe cannot put it into the trench and in place without allowing earth to get inside, then place a heavy, tightly woven canvas bag or plug of suitable size over each end of the pipe, and leave in place until it is time to connect that pipe to the adjacent pipe.
- F. Place no debris, tools, clothing, or other materials in the pipe during laying operations.
- G. After a length of pipe has been placed in the trench, center the spigot end in the bell of the adjacent pipe, and insert to the depth specified by the manufacturer and bring to the correct line and grade. Secure the pipe in place by tamping an approved backfill material around it.
- H. Bell holes shall be large enough so that there is ample room for the pipe joints to be properly made. Between bell holes, carefully grade the bottom of the trench so each pipe barrel rests on a solid foundation for its entire length.

- I. Whenever pipe laying is not in progress, close the open ends of pipe either with a watertight plug or by other means approved by the Town of Chapel Hill. If there is water in a trench, leave this seal in place until the trench has been pumped completely dry.
- J. Cut pipe so that valves, fittings, or closure pieces can be inserted in a neat workmanlike manner without any damage to the pipe. Follow the manufacturer's recommendations concerning how to cut and machine the ends of the pipe in order to leave a smooth end at right angles to the pipe's axis.
- K. Lay pipe with the bell ends facing in the direction of laying unless otherwise directed by the Town of Chapel Hill.
- L. Wherever pipe must be deflected from a straight line (in either the vertical or horizontal plane) in order to avoid obstructions or plumb stems, or wherever long radius curves are permitted, the amount of deflection shall not exceed that necessary for the joint to be satisfactorily made, nor that recommended by the pipe manufacturer, and shall be approved by the Town of Chapel Hill.
- M. Lay no pipe in water or when it is the Town of Chapel Hill's opinion that trench conditions are unsuitable. If crushed stone is used to improve trench conditions or as backfill for bedding the pipe, its use is considered incidental to the project, and no separate payment will be made for its use unless prior written approval is obtained from Engineer.
- N. Where a water line crosses over a sanitary sewer, use a full joint of pipe with a standard mechanical joint, and center over the sewer. Where a water line is to be parallel to a sanitary or storm sewer, lay it at least ten (10) feet from the sewer. If it is not practical for the water and sewer lines to be separated as described above, then lay the water line at least 18 inches above the top of the sewer.
- O. Joint all pipe in the exact manner specified by the manufacturer of the pipe and jointing materials.
- P. As an attempt to verify quality of the PVC water pipe prior to installation of all pipe, the following procedure will be required. After the Contractor has laid between one to two thousand feet of pipe, said pipe shall be pressure tested in accordance with these specifications. Only upon satisfactory completion of the testing will the Contractor be allowed to continue laying pipe. If the quality of the pipe becomes suspect at any other point in the project, testing will be required prior to continuation of the pipe laying.

- Q. Connecting to Existing Lines
1. Connections of new lines to existing lines shall be as shown on the Plans and/or directed by the Town of Chapel Hill.
 2. The Contractor shall be completely responsible for determining existing pipeline materials, ordering proper fittings for the connection, and making the connection in an approved manner.
- R. All new mains shall have a construction tap placed approximately every 1,200 linear feet for sampling and blow-off during testing.
- S. Use of Sleeves
1. Mechanical joint sleeves may be used to facilitate connection of new water lines to existing water lines, existing valves, existing tees, etc.
 2. A mechanical joint sleeve may be used to repair a leak in the event a leak is the result of a rolled or defective pipe gasket. However, only one (1) sleeve is permitted every 2,500 feet of newly installed water line. If the water line fails to pressure test and multiple (more than 1) pipe defects are evident, then the defective line shall be removed and re-installed to such a point extending to a valve or other fitting in the water line.

3.03 BEDDING AND BACKFILLING

- A. Begin backfilling after the line construction is completed and then inspected and approved by the Town of Chapel Hill. In an earth trench, for PVC or DIP pipe material, on each side of the line, from the bottom of barrel of pipe to 12 inches above the top of the pipe, the backfill material shall be select backfill consisting of fine, loose earth like sandy soil or loam or of granular material that is free from clods, vegetable matter, debris, stone, and/or other objectionable materials and that has a size of no more than 2 inches. Place this backfill simultaneously on either side of the pipe in even layers that, before compaction, are no more than 6" deep. Thoroughly and completely tamp each layer into place before placing additional layers.
- B. From 1' above the pipe upward (if outside paved area or roadway) the backfill material may contain broken stones that make up approximately 3/4 of the backfill's total volume. However, if this type of backfill is used, there must be enough spalls and earth materials to fill all voids completely. The maximum dimension of individual stones in such backfill shall not exceed 6", and the backfill material shall be placed and spread in even layers not more than 12" deep. Tamp and thoroughly compact the backfill in layers that, before compaction, are 6" deep. In

other areas, the backfill for the upper portion of the trenches may be placed without tamping but shall be compacted to a density equivalent to that of adjacent earth material as determined by laboratory tests. Use special care to prevent the operation of backfilling equipment from causing any damage to the pipe.

- C. If earth material for backfill is, in the opinion of the Town of Chapel Hill, too dry to allow thorough compaction, then add enough water so that the backfill can be properly compacted. Do not place earth material the Town of Chapel Hill considers too wet or otherwise unsuitable.
- D. If PVC or DIP pipe is installed in a rock trench or paved area/roadway, install a 6" bedding of No. 67 crushed stone below the pipe.
- E. In paved areas or roadways, backfill for PVC or DIP pipe shall be No. 67 crushed stone to a point, and from said point there shall be 8-inches of Class A, Grade D, crushed stone installed plus binder and topping (thickness of binder and topping to be installed in accordance with the governing highway department). Until binder and topping are installed, crushed roadway base stone shall be installed flush with the existing pavement and maintained until final paving restoration occurs or until the project is accepted by the Town of Chapel Hill.
- F. In a rock trench, backfill shall be No. 67 crushed stone to a point 12-inches above the top of PVC or DIP pipe.
- G. Wherever excavation has been made within easements across private property, the top 1' of backfill material shall consist of fine loose earth free from large clods, vegetable matter, debris, stone, and/or other objectionable materials.
- H. Wherever pipes have diameter of 15" or less, do not use power operated tampers to tamp that portion of backfill around the pipe within 1' above the pipe.
- I. Perform backfilling so as not to disturb or injure any pipe and/or structure against which the backfill is being placed. If any pipe or structure is damaged and/or displaced during backfilling, open up the backfill and make whatever repairs are necessary.
- J. Backfilling and clean-up operations shall closely follow pipe laying; failure to comply with this provision will result in the Town of Chapel Hill's requiring that the Contractor's other activities be suspended until backfilling and clean-up operations catch up with pipe laying.

3.04 PRESSURE TESTS

- A. After pipe has been laid and backfilled as specified above, subject all newly laid pipe or any valved section thereof to a minimum pressure of 200 psi or 1.5 times the working pressure, whichever is greater, but in no case greater than the pipe pressure rating. All pipe shall be tested within two (2) weeks of installation.
- B. The duration of the pressure test shall be at least two (2) hours. Test pressure shall not vary more than ± 5 psi for the duration of the test.
- C. Slowly fill each valved section of pipe with water, and apply the specified test pressure (based on the elevation of the lowest point of the line or section under test and corrected to the elevation of the test gauge) with a pump connected to the pipe in a manner satisfactory to the Town of Chapel Hill. Furnish the pump, pipe, connections, gauges, and all necessary apparatus.
- D. Before applying the specified test pressure, expel all air from pipe. If hydrants or blow-offs are not available at high places, make the necessary taps at the points of highest elevation before testing, and close taps after the test has been completed.
- E. Carefully examine all exposed pipes, fittings, valves, and hydrants during the test. Remove any cracked or defective pipes, fittings, valves or hydrants discovered in consequence of this pressure test, and replace with sound material in the manner specified. Repeat the test until the results are satisfactory to the Town of Chapel Hill.
- F. Prepare reports of all pressure test activities. Pressure tests shall be conducted utilizing a recording device and paper circular pressure chart. A copy of the pressure chart shall be provided to the Town of Chapel Hill upon completion of satisfactory testing.

3.05 LEAKAGE TEST

- A. Conduct the leakage test after the pressure test has been satisfactorily completed. Furnish the pump, pipe, connections, gauges, measuring devices, and all other necessary apparatus as well as all necessary assistance to conduct the test.
- B. The duration of each leakage test shall be two (2) hours; during the test, subject the main to a pressure of 200 psi.
- C. Should any test of pipe laid disclose leakage greater than that specified the Contractor shall, at his own expense, locate and repair the defective joints

until the leakage is within the specified allowance. All visible leaks are to be repaired regardless of amount of leakage.

- D. Leakage defined: Leakage shall be defined as the quantity of water that must be supplied into the newly laid pipe or any valved section thereof in order to maintain pressure within 5 psi of the specified test pressure after the pipe has been filled with water and the air expelled. Leakage shall not be measured by a drop in pressure in a test section over a period of time.
- E. Allowable Leakage: No pipe installation will be accepted if the leakage is greater than that determined by the following formula:

1. Ductile Iron Pipe:
$$L = \frac{SD\sqrt{P}}{133,200}$$

Where: L = allowable leakage, in gallons per day.
 S = length of pipe tested, in feet.
 D = nominal diameter of the pipe, in inches.
 P = average test pressure during the leakage tests, in Pounds per square inch (gauge).

Average Test Pressure (psi)	Nominal Pipe Diameter - Inches				
	4	6	8	10	12
200	0.38	0.57	0.76	0.96	1.15
175	0.36	0.54	0.72	0.89	1.07
150	0.33	0.50	0.66	0.83	0.99

* If the pipeline under test contains sections of various diameters, the allowable leakage will be the sum of the computed leakage for each size.

2. PVC Pipe:
$$L = \frac{ND\sqrt{P}}{7,400}$$

Where: L = allowable leakage, in gallons per hour
 S = length of pipe tested in feet
 N = number of joints in the length of pipeline tested
 D = nominal diameter of the pipe, in inches
 P = average test pressure during the leakage tests, in pounds per square inch (gauge)

Average Test Pressure (psi)	Nominal Pipe Diameter - Inches				
	4	6	8	10	12
200	0.38	0.57	0.76	0.96	1.15
175	0.36	0.54	0.72	0.89	1.07
150	0.33	0.50	0.66	0.83	0.99

* If pipeline under test contains sections of various diameters, the allowable leakage will be the sum of the computed leakage for each size.

3. HDPE Pipe:

TABLE 3: ALLOWABLE MAKE-UP AMOUNT (HDPE) PIPE	
Nominal Pipe Size (inches)	Make-up Water Allowance (U.S. Gallons /100 ft. of Pipe) 2-Hour Test
6	0.30
8	0.50
10	0.65
12	1.15
14	1.40
16	1.65
18	2.15
20	2.75
22	3.50
24	4.40
26	5.00
28	5.55
30	6.35
32	7.15
34	8.10
36	9.00
42	11.55
48	13.50
54	15.70

- F. When testing against closed metal-seated valves, an additional leakage per closed valve of 0.0078 gal/h/in of nominal valve size shall be allowed. When hydrants are in the test section, the test shall be made against the closed main valve in the hydrant. All visible leaks are to be repaired regardless of the amount of leakage.

3.06 DISINFECTION AND BACTERIOLOGICAL TESTING

- A. During construction, take precautions to protect pipe interiors, fittings, and valves against contamination. When pipe laying is not in progress (e.g., at the end of the day's work), place watertight plugs in the ends of all pipe already in the trench; if water accumulates in the trench, leave the plugs in place until the trench is dry. Complete the joints of all pipe in the trench before stopping work for any reason.
- B. Pipe laid in wet trenches must contain an available chlorine concentration of approximately 25mg/L. This may be accomplished by adding HTH to each length of pipe before it is lowered into a wet trench or by treating water with hypo-chlorite tablets. Every effort must be taken to minimize dirt and debris from entering the pipe.

- C. Where new line construction includes making customer taps, chlorine samples must be taken at each tap and documented before meters will be installed. The minimum chlorine residual is 0.2 mg/L, with maximum of 4.0 mg/L.
- D. During the installation of the new water main, place calcium hypochlorite granules or tablets at the upstream end of the first section of pipe, at the upstream end of each branch main, and at 500-ft intervals. The quantity of granules at each location shall be as shown in Table 4, Section 3.01.
- E. Upon completion of the water line installation, make water flow from the existing distribution Town of Chapel Hill or some other approved source into the newly laid pipeline, and add chlorine to it. Feed water into the pipe, and chlorine into the water, at constant, measured rates so proportioned that the chlorine concentration in the water in the pipe is kept at a minimum of 25 mg/l.
- F. While the chlorine is being applied, manipulate valves so that the treatment dosage will not flow back into the line that is supplying the water. Continue the application of chlorine until the entire line being treated is filled with the chlorine solution. Then retain the chlorinated water in the line for at least 24 hours, during which time all valves and hydrants in the line being treated shall be operated so that appurtenances can also be disinfected. After 24 hours, the treated water in all portions of the main shall have a residual of not less than 10 mg/l of free chlorine.
- G. Final flushing shall be conducted in accordance with AWWA C651. After applicable retention period, flush heavily chlorinated water from line until chlorine concentration in water leaving the main is no higher than that generally prevailing in the Town of Chapel Hill, but not less than 0.2 mg/l. Perform such flushing only at approved sites. If no approved point of discharge is available, neutralizing chemicals must be applied to the water in order to neutralize the chlorine residual. See Table 4 below.

TABLE 4 Amounts of Chemicals Required to Neutralize Various Residual Chlorine Concentration in 100,000 Gallons of Water								
Chemical Required								
Residual Chlorine Concentration	Sulfur Dioxide (SO ₂)		Sodium Bisulfite (NaHSO ₃)		Sodium Sulfate (Na ₂ HSO ₃)		Sodium Thiosulfate (Na ₂ S ₂ O ₃ ·5H ₂ O)	
	<i>mg/L</i>	<i>lb.</i>	<i>(kg)</i>	<i>lb.</i>	<i>(kg)</i>	<i>lb.</i>	<i>(kg)</i>	<i>lb.</i>
1	0.8	(.36)	1.2	(.54)	1.4	(.64)	1.2	(.54)
2	1.7	(.77)	2.5	(1.13)	2.9	(1.32)	2.4	(1.09)
10	8.3	(3.76)	12.5	(5.67)	14.6	(6.62)	12.0	(5.44)
50	41.7	(18.91)	62.6	(28.39)	73.0	(33.11)	60.0	(27.22)

- H. At all times, avoid dumping heavily chlorinated water or its runoff into creeks, streams, or where water may enter a well. Where necessary, State, Federal, and Local Regulatory Agencies should be contacted to determine special provisions for the disposal of heavily chlorinated water.
- I. After a water line has undergone final flushing but before it is placed into service, two (2) consecutive acceptable water samples taken at least 24 hours apart or one (1) water sample taken after 48 hours, shall be collected for bacteriological testing. In the case of extremely long lines, additional samples may be collected if the Town of Chapel Hill so directs. A bacteriological sample shall be taken from each dead-end line, branch line, and at approximately 2,500-foot intervals. Tests shall be in accordance with AWWA C651.
- J. Samples shall be collected in sterile bottles treated with sodium thiosulfate. No hoses or fire hydrants shall be used to collect samples. Town of Chapel Hill will provide the sample bottles and collect the samples.
- K. All samples shall be tested for biological (chemical and physical) quality in accordance with the Standard Methods for the Examination of Water and Wastewater, and shall show the absence of coliform organisms.
- L. If the initial disinfection fails to produce satisfactory bacteriological results, or if the water quality is affected, the new pipe shall be re-flushed and re-sampled. If the samples fail to produce acceptable results, the pipe shall be re-chlorinated by the slug method until satisfactory results are obtained.

3.08 DISINFECTION PROCEDURE AFTER CUTTING INTO OR REPAIRING EXISTING LINES.

- A. During line repairs, the integrity of the line must be maintained. This shall be accomplished by the following:
1. Valve off the line downstream from leak.
 2. Reduce the flow upstream from the leak but allow enough flow to maintain a positive pressure at the leak site.
 3. Cover shall be removed from the line at the leak and a hole approximately 18" lower than the line shall be dug. Excess water shall be pumped or dipped from the hole until all cover is removed from the pipe at the leak.
 4. If the leak can be repaired with a full circle clamp, repair will be made, the line will be flushed and service restored. No further action will be taken.
- B. If the line will have to be cut and section replaced, the following actions will be taken:
1. Upstream and downstream valves will be closed and excess water will continue to be pumped from the leak site and all cover will be removed from pipe at least 18" in both directions from the cut sites on pipe.
 2. The customer's service will be cut off to protect from contaminants.
 3. A 1% hypo-chlorite solution will be prepared by adding 2 oz of 65% HTH to 1 gallon of water.
 4. The surrounding area will be checked for signs of broken sewer or septic lines and animal waste. If present, special care must be taken and some of the 1% hypo-chlorite solution should be scattered around the work site.
 5. Work can now proceed with the cutting of the pipe. Once the defective section is removed, both ends of the remaining pipe should be checked and any debris from pipe cuttings or other sources should be removed.
 6. The new section of pipe and both ends of the remaining pipe should be swabbed with the 1% hypo-chlorite solution and repairs completed.

7. Upstream valve will be opened and the nearest hydrant downstream of the line leak will be flushed vigorously at a velocity of at least 2 ft. per second. Highly chlorinated water should be de-chlorinated. To determine how long to flush a line, divide the estimated distance (feet) between the upstream valve and the nearest flushing site by two. Example (if the flushing point is 3000 ft. from the leak site the line should be flushed a minimum of 1500 sec or 25 minutes.) Flushing shall continue until chlorine residual readings are equal at the flushing site and at a site upstream from the repair line. In addition, flushing shall continue until turbid water is no longer visible at the flushing site. These steps will be taken on the downstream valve as the upstream valve.
8. After the line is flushed at least one bacteria sample shall be obtained immediately prior to service being restored. This sample shall be coded as type "D". If the sample is negative no further action is required other than to properly and fully document the repaired event and procedures. If the sample is positive, then the original positive site will be resample and 3 repeat samples will be obtained in the downstream area of the repair and from customer taps within 24 hours of notification of the positive sample. The original site will be coded as an "R", and each of the three downstream samples will be coded as an "R", repeat distribution samples, and will be counted as compliance samples.
9. If all 4 samples are negative, no further action will be taken. If the sample from the original site is positive and the other 3 are negative, the system may ask the state to invalidate the sample as site specific due to a contaminated tap and no further action will be required. If any of the downstream samples are positive, normal repeat sample monitoring procedures become effective. If any repeat sample is fecal coliform positive or E-coli positive or if the repeat sample following an initial positive fecal coliform or E-coli sample is total coliform positive, the system will issue a Tier-1 Boil Water Notice.
10. If it is suspected that the line may have had contaminants enter the line, slug disinfection shall be employed to disinfect the line. The line shall be slug disinfected from closed valve to closed valve. Affected customers services will be shut-off to protect customers from high levels of disinfectant. Slug disinfection consists of putting HTH in a line, completely filling the line with water and slowly flowing the slug of water through the line. The slug should contain about 100ppm free chlorine and flow rates adjusted to keep the chlorine in contact with the line for about three hours. Chlorine will be added to the line in addition to all of the above procedures. Chlorine doses needed per 1000 feet of pipe: 2" pipe 1oz of 65% HTH, 4" pipe 4oz of HTH, 6"

pipe 8oz of HTH, 8" pipe 16oz of HTH will produce about 25 ppm free chlorine. If the suspected contaminant is not affected by chlorine, alternative measures must be employed to remove the contamination.

- C. Service line of one-inch diameter or less will not have any samples taken or additional disinfectant added. The leak will be clamped off to prevent any contaminant from entering the main line. The service line will be flushed and chlorine residual will be taken. Water lines that is larger than one-inch in diameter will be treated as a water main.
 - D. For any repair procedure, detailed records of the repair must be prepared documenting the procedure utilized, disinfection information, contact time, dose calculations, bacteriological sample time and location. Bacteriological sample results shall be attached to corresponding repair records.
- 3.09 FINAL WATER LINE ACCEPTANCE
- A. After completing each section of water line, remove all debris and all construction materials from the work site. Then grade and smooth over the surface of both sides of the line. Leave the entire area clean and in a condition satisfactory to the Town of Chapel Hill.

END OF SECTION

SECTION 5.02

WATER VALVES, HYDRANTS, AND APPURTENANCES

PART 1 – GENERAL

1.01 SECTION INCLUDES

- A. Installation of fire hydrants, valves, and related accessories as specified below.
- B. Refer to other sections for work related to that specified under this heading.

PART 2 - PRODUCTS

2.01 GATE VALVES

- A. Valves on water lines 12 inches and smaller shall be of the resilient seat and have a ductile iron body, bonnet, and O-ring plate. The body, bonnet, and O-ring plate shall be fusion-bond epoxy coated, both interior and exterior on body and bonnet. Epoxy shall be applied in accordance with AWWA C550 and be NSF 61 certified. The sealing rubber shall be permanently bonded to the wedge per ASTM D429 and the stems shall be cast copper alloy with integral collars in full compliance with AWWA. The valve shall be designed to work equally well with pressure on either side of the gate. All gate valves shall be in accordance with or exceed AWWA C515. Working pressure shall be 200 psi.
- B. Valves shall be supplied with O-ring seals at all pressure retaining joints, two-inch square operating nut, non-rising stem and shall open to the left. Valves shall be M&H, or approved equal, with mechanical joints.

2.02 BUTTERFLY VALVES

- A. Butterfly valves shall be used on all water lines larger than 12-inches in diameter.
- B. All valves shall be of the rubber-seated tight-closing type. They shall meet or exceed performance requirements of AWWA C504-06. Valves shall be bubble-tight at rated pressures with flow in either direction, and shall be satisfactory for application involving throttling service and/or frequent operations and for application involving valve operation after long periods. Valves shall be Class 150B for buried service.
- C. Both ends of valve shall have integrally cast mechanical joint ends in accordance with AWWA C111. Accessories shall be supplied by the valve manufacturer.
- D. Valve bodies shall be constructed of ductile iron ASTM A536.

- E. Valve discs shall be ductile iron ASTM A536 and furnished with 316 stainless steel seating edge to mate with the rubber seat.
- F. Valve seats shall be Buna-N rubber located on the valve body.
- G. Valve shafts shall be stainless steel ASTM A564, Type 630 with stub shaft design for 24" valves and larger and 1 piece shafts for 3" through 20".
- H. Shaft seals shall be Buna N self-adjusting., Chevron V-type packing or o-ring type. Shaft seals shall be of a design allowing replacement without using the valve shaft.
- I. Valve bearings shall be sleeve-type that are corrosion resistant and self-lubricating.
- J. Valve actuators shall be fully grease packed and have stops in the open/close positions. The actuator shall have a mechanical stop which will withstand and input torque of 450 ft-lbs. against each stop.
- K. Valve interior and exterior surfaces shall be coated in accordance with TT-C-494A and AWWA C504.
- L. All valves shall be hydrostatic and leak tested as required by AWWA C504.
- N. Butterfly valves shall be M&H Style 4500, or approved equal.

2.03 TAPPING VALVES AND TAPPING SLEEVES

- A. Tapping valves shall meet all the requirements of 2.01 above.
- B. Tapping sleeves shall be two-piece fabricated stainless steel with adjusting/tightening bolts on each side. The fabricated sleeve must contain all stainless materials and be rated for 150 psi working pressure. The connecting gasket and outlet gasket shall be Buna-N rubber per ASTM D2000. The tapping sleeve shall be NSF 61 listed and meet applicable AWWA C223 standards. The outlet shall have a no-lead brass test plug. Care must be used to assure that all bolts are equally tightened. The tapping valve is to be solidly supported with brick or block and carefully bedded to prevent shifting due to settling back fill.
- C. Tapping sleeves shall be Smith-Blair Model 665, or approved equal, with mechanical joints.
- D. Pipe shall be cleaned of all dirt and debris where tapping sleeve is to be located. Tapping sleeve shall be installed in the direction of the new line. Do not rotate the tapping sleeve on the existing pipe as it may damage the liner. Tighten and torque all tapping sleeve bolts in accordance with the manufacturer's recommendations. After initial application of the sleeve and tightening of the

bolts, wait a minimum of 24 hours and then re-tighten the bolts and re-check the torque. **Town of Chapel Hill** personnel shall be present to witness torquing of tapping sleeve bolts. Checking bolt tightness without a torque wrench will result in tapping sleeve being failed and unready for tapping. Verify operating pressure of line to be tapped with **Town of Chapel Hill** personnel.

- G. Install the tapping valve. Provide adequate support to the tapping valve. Prior to tapping the line, the tapping sleeve and valve shall be air tested. For lines up thru 24-inch, the air test shall be 100 psi and the duration of the test shall be for a maximum of 5 minutes.
- H. Perform the tap. Provide adequate support of the tapping machine so as to not impart undue stress on the water line or tapping sleeve assembly. Upon completion of the tap, close the tapping valve and remove the tapping machine. Check for any leaks and repair if any are evident. Make the coupon available for inspection by **Town of Chapel Hill** personnel.
- I. A concrete kicker shall be poured behind each tapping sleeve prior to backfilling and connecting the new line.

2.04 VALVE BOXES

- A. All valve box castings shall be made accurately to the required dimensions, and shall be sound, smooth, clean, and free from blisters and other defects. Defective castings which have been plugged or otherwise treated to remedy defects shall be rejected. Contact surfaces of frames and covers shall be machined so that the covers rest securely in the frames with no rocking and with the cover in contact with the frames for the entire perimeter of the contact surface. All castings shall be thoroughly cleaned subsequent to machining and before rusting begins, painted with a bituminous coating so as to present a smooth finish, tough and tenacious when cold, but not tacky with no tendency to scale. Install valve boxes on each proposed valve in accordance with the details shown on the standard drawings.

2.05 FIRE HYDRANTS

- A. Fire hydrants shall comply in all respects with AWWA C502 and shall be of the compression type, with the main valve opening against the pressure and closing with the pressure. The main valve opening shall be 4-1/2 inches in diameter. The main valve facing of the hydrant shall be made of balata or similar material especially suited and proven for the services intended. The bottom stem threads of the main valve rod shall be fitted with an acorn nut or suitable means for sealing the threads away from the water. Hydrants shall be connected to the main by a 6 inch mechanical joint shoe, unless otherwise shown on the drawings, and fitted with strapping lugs. For fire hydrants, two 2-1/2 inch hose nozzles and one 4-1/2 inch steamer nozzle shall be threaded and screwed into the nozzle section and then pinned to prevent turning.

- B. Operating nut shall be pentagon-shaped and provided with convenient means to afford lubrication to ensure ease of operation and the prevention of wear and corrosion.
- C. Hydrant shall be the dry barrel type, and hydrant shoe shall have two positive acting non-corrodible drain valves that drain the hydrant completely by opening as soon as the main valve is closed and by closing tightly when the main valve is open. Drain valves operated by springs or gravity will not be acceptable.
- D. The packing gland located in the bonnet shall be solid bronze, and gland bolts shall steel with bronze nuts. A double O-ring seal may be used in lieu of conventional stuffing box.
- E. The hydrant shall open by being turned to the left (or counterclockwise) and be so marked on the bonnet in cast letters with an arrow.
- F. Threads on hose and steamer nipples, operating nut, and cap nuts shall conform to local Fire Department standards.
- G. Bury shall be of sufficient length so that the flange break-away is located a minimum of 4 inches above finished grade and the pipe has the required minimum coverage of 30 inches.
- H. All pipe installed between the locking Tee and fire hydrant shall be ductile iron pipe, and two (2) stainless steel tie rods shall be utilized on each fitting, in addition to restraint fitting devices such as Megalug restraints.
- H. Hydrants shall be M&H, Model 129, or approved equal. Color shall be red.

2.06 AIR RELEASE VALVES

- A. Air release valves shall be automatic type and be a A.R.I. Model S-050 air release valve. Valve shall be placed inside a meter box as noted on the Standard Details.

2.07 BLOW-OFF ASSEMBLIES

- A. Blow-off assemblies shall be complete assembly and as set forth in the Standard Details.

2.08 POST HYDRANTS

- A. Post hydrants shall be connected to the main by means of a 2-inch threaded connection as shown in the Standard Details. Post hydrants shall be dry barrel design and meet the applicable requirements of AWWA C502.
- B. Post hydrants shall be compression type main valve opening against pressure and closing against pressure. The shoe shall be fitted with drains to allow for drainage

upon closure. The hydrant shall be pressure rated for at least 150 psi working pressure.

- C. Hose nozzles shall be threaded and screwed into the nozzle section. Post hydrant shall be furnished with one, 2-1/2" hose nozzle. Hydrant nut shall be pentagon shaped and hydrant shall be painted red. Hose caps shall be chained to the hydrant body.
- D. Post hydrants shall be M&H 2-1/2" Style 33, or approved equal.

2.10 FOSTER ADAPTORS

- A. Mechanical joint valves and fittings shall be connected using a bolt-through positive restraint mechanism manufactured of ductile iron conforming to ASTM A536-65-45-12. The positive restraint device shall connect the valves and/or fittings at a linear distance not to exceed three (3) inches and without attachment to the pipe. The device shall come complete with all accessories, including standard styrene butadiene rubber (SBR) MJ gaskets conforming to the latest revision of AWWA C111/ASTM F-477 and weathering steel (Corten) bolts conforming to AWWA C111/A21.11 and ASTM A242. Nuts for 3 through 12-inch sizes shall be SAE Grade 5 steel with black oxide coating. Nuts for 14-inch and larger adaptors shall be heavy hex Corten steel conforming to ASTM A242. Sizes 3-12 inch of the bolt-through MJ positive restraining device shall be supplied with NSF-61 asphaltic seal, coating in accordance with ANSI/AWWA C104/A21.4. Sizes 14-26-inch shall be supplied with NSF 61, 7 mil fusion bonded epoxy conforming to AWWA C116/A21.16-09 as well as the coating, surface preparation and application requirements of ANSI/AWWA C550. The device shall be used with standard mechanical joint fittings (AWWA C110 or C153) and valves. The device shall be furnished by Infact Corporation or approved equal.

PART 3 - EXECUTION

3.01 SETTING VALVES AND APPURTENANCES

- A. General: Set valves, fittings, plugs, and caps and joint to pipe in the manner heretofore specified for cleaning, laying, and jointing pipe. Use Foster Adaptors where applicable to connect valves to fittings in lieu of short sections of non-restrained pipe.
- B. Tapping sleeves shall be separately pressure tested before connection to the new water line. The Town of Chapel Hill must witness the tapping saddle pressure test. Tapping sleeves shall be properly centered and torqued prior to testing. Adequate support for tapping sleeves shall be provided to avoid placing stress on the existing line. A concrete reaction block shall be poured behind the tapping sleeve prior to making the tap. All bolts on the sleeve shall be protected by plastic to avoid covering them with concrete.

- C. The Town of Chapel Hill will not perform taps for water lines. The cost of the tap shall be borne by the Contractor. The Contractor will be required to excavate for installation of the tapping saddle and tapping valve and install both devices in preparation for the tap. The aforementioned pressure test shall already be completed. The coupon from taps shall be provided to the Town of Chapel Hill.
- D. Location of Valves: Valves in water mains shall, where possible, be located on the street property lines extended unless otherwise shown on the drawings. Valves shall not be located in paved areas without prior approval of the Town of Chapel Hill.
- E. Valve Boxes: Provide a valve box for every valve. The valve box shall not transmit shock or stress to the valve and shall be centered and plumb over the wrench nut of the valve, with the box cover flush with the surface of the finished pavement or such other level as may be directed by the Town of Chapel Hill. No PVC pipe will be allowed as a valve box.
- F. Provide a concrete collar around each valve located in unpaved areas.
- G. Blow-off assemblies and air release valves shall be installed in meter boxes as shown on the Standard Details. Devices shall be provided with an isolation ball valve and brass nipples.

3.02 SETTING HYDRANTS

- A. Location: Locate hydrants as shown on the drawings or as directed by the Town of Chapel Hill and in a manner that will provide complete accessibility and also minimize the possibility of damage from vehicles or injury to pedestrians.
- B. Position: All hydrants shall stand plumb. Set hydrants to the established grade, with nozzles at least 12 inches above the ground, as shown on the drawings or as directed by the Town of Chapel Hill. If hydrant is required to adjust height to 12 inches, this adjustment shall be supplied by the contractor.
- C. Connection to Main: Connect each hydrant to the main with a ductile iron mechanical joint tee, or hydrant anchor tee and 6-inch gate valve. Valve and fittings and hydrant shoe shall be installed using Mega-lug style restraint devices.
- D. Hydrant Drainage: Provide drainage at the base of the hydrant by placing coarse gravel or crushed stone from the bottom of the trench to at least 6 inches above the waste opening in the hydrant to a distance of 1 foot around the elbow. Connect no drainage system to a sewer.
- E. Anchorage for Hydrants: Rod the gate valve ahead of each hydrant to the tee, and rod the hydrant from the gate valve. Mega-lug style restraint devices may also be used to restrain the hydrant and the isolation valve. Brace the bowl of each hydrant well against unexcavated earth at the end of the trench with a concrete

kicker. Where rods cannot be used, metal harness may be used. Metal harness, steel rods, or clamps shall be galvanized or otherwise rustproof treated.

- F. Post hydrants shall be preceded by a 2-inch gate valve with valve box to provide for isolation of the post hydrant. The valve shall be rodded to the hydrant.

END OF SECTION

SECTION 5.03

WATER SERVICE ASSEMBLIES

PART 1 - GENERAL

1.01 SECTION INCLUDES

- A. Service assembly requirements for 3/4-inch service connections.

PART 2 - PRODUCTS

2.01 SERVICE ASSEMBLY

- A. All service fittings and meters shall be certified lead-free.
- B. The service assembly shall include a corporation cock, copper service pipe gooseneck, meter, meter box, and tapping saddle as required.
- C. **CORPORATION STOP:** The corporation stop shall be designed and manufactured to conform to AWWA C800. Inlet threads shall be AWWA/CC taper thread. The outlet shall be suitable for the service piping required. Corporation stop shall be directly tapped into the water line/main using a tapping saddle. Insulators shall be used on dissimilar pipes as necessary for protection against electrolysis. The corporation stop shall be 3/4" Ford F1000-3-Q-NL style.
- D. **TAPPING SADDLES:** Tapping saddles shall be used for tapping all PVC or DIP pipe and shall be Ford S70 series, and shall be AWWA threaded to accept the corporation cock specified above. Tapping saddle body and strap shall be made of brass alloy and shall be joined together with stainless steel pin. No taps larger than 3/4" inch shall be made in any size pipe without approval by the Town of Chapel Hill.
- E. **SERVICE PIPE:** Service pipe shall be 3/4 inch PEXa Municipex by Rehau®. Service pipe under streets or roadways shall be installed in 2-inch diameter DR 9 HDPE casing pipe for 3/4-inch or 1-inch service lines. Depth of pipe is to be no less than eighteen inches (18") and no more than twenty-four inches (24"). PEXa service pipe, if used shall be installed with a 14 ga. tracer wire for location of service line. Tracer shall be connected to the service corporation or ductile water main and the line setter.
- F. **LINE SETTERS:** Line setter shall have inlet key valve, single check outlet valve and appropriate ends for connecting to the type of service line specified. Line setter shall have sufficient height to raise the meter above the bottom of meter box and have brace pipe eyelets. Line setter shall be Ford Model LSVBH41-233W-Q-NL, or approved equal.

- G. WATER METERS: The Town of Chapel Hill will furnish water meters as needed unless otherwise directed.
- H. METER BOXES: Meter boxes shall be HDPE Carson Model 1015 and the lid shall be Carson Model 10154075 with touch read hole option included.

2.02 REDUCED PRESSURE BACKFLOW PREVENTER

- A. Reduced pressure backflow preventer device shall be installed at each cross-connection to prevent backsiphonage and backpressure backflow of hazardous materials into the potable water supply. If the assembly is installed in a location with more than its rated working pressure, a water pressure regulator shall be installed upstream of the assembly.
- B. The assembly shall consist of a pressure differential relief valve located in a zone between two positive seating check valves.
- C. Backsiphonage protection shall include provision to admit air directly into the reduced pressure zone via a separate channel from the water discharge channel, or directly into the supply pipe via a separate vent.
- D. The assembly shall include two quarter-turn ball valves before and after the check valves, test cocks, and air gap.
- E. An approved strainer, fitted with a test cock, shall be installed immediately upstream of all backflow devices or shut-off valves except on fire lines, using only non-corrosive fittings (e.g., brass or bronze) in the device assembly.
- F. Backflow devices shall be located so that the relief valve discharge port in a minimum of 12-inches, plus the nominal diameter of the supply line, above the ground surface. Maximum height above the floor surface shall not exceed 60-inches.
- G. Clearance of devices from wall surfaces or other obstructions shall be a minimum of 6-inches; or, if a person must enter the enclosure for repair or testing, the minimum distance shall be 24-inches.
- H. Devices shall be located in an area free from submergence or flood potential.
- I. Devices shall be protected from freezing, vandalism, mechanical abuse, and from any corrosive, sticky, greasy, abrasive, or other damaging substance.
- J. The assembly shall meet the requirements of ASSE Standard 1013, AWWA C-511-92 CSA B64.4, and national plumbing codes.
- K. Materials:
 - 1. Check Valve Body: Lead Free Cast Copper Silicon Alloy

2. Check Valve Seat: 909 Celcon
 3. Relief Valve Seat: Stainless Steel 909HW
 4. Test Cocks: Lead Free Cast Copper Silicon Alloy
 5. Strainer: BronzeL. Drain lines shall be provided for assembly discharge.
- M. Reduced Pressure Backflow Preventer Device shall be Watts Series LF909, or approved equal.

PART 3 – EXECUTION

3.01 PREPARATION

- A. Make no taps on dry lines without approval from the Town of Chapel Hill. Taps in newly installed water line shall be made by the Contractor. Taps on existing water lines shall be made by the Town of Chapel Hill.
- B. Contractor shall make all service taps on new lines.
- C. The service line shall have a minimum of 18 inches cover. Prior to connecting meter, blow any accumulated trash out of the pipe.

3.02 INSTALLATION

- A. All service lines to be installed under paved county or state roads will be bored and jacked. A 2-inch diameter DR 9 HDPE casing pipe shall be provided for 3/4-inch or 1-inch service lines that are bored or open-cut installed under roadways. No couplings shall be used on new service lines.
- B. In general, install the meter box as near the property lines as possible in the street right-of-way. Set plumb approximately 1 inch above the existing or proposed grade and so that surface drainage will not enter it. Fill from the existing or proposed grade to the top of the meter box at a slope of 1 inch in 12 inches. When the cut or fill slopes on streets extend beyond the street right-of-way, install the meter box at the top or toe of slope, as applicable, or as directed by the Town of Chapel Hill.
- C. The service main shall not be taut from stop to cock. A gooseneck shall be left at the connection to the water main.
- D. The Reduced Pressure Backflow Preventer Assembly shall be installed in a highly visible location that facilitates testing and servicing, and protects against freezing and vandalism.

END OF SECTION

SECTION 6.01

BASE AND SUBGRADE TREATMENT

PART 1 – GENERAL

1.01 WORK INCLUDED

- A. This work shall consist of the construction and preparation of part or all of the roadbed to receive the immediate construction of a base or pavement thereon.
- B. This work shall consist of furnishing and placing one or more courses of aggregates, and additives if required, on a prepared subgrade in accordance with these specifications and in reasonably close conformity with the lines, grades, thickness and typical sections shown on the Plans.

1.02 RELATED WORK

- A. Section 3.01 Clearing
- B. Section 3.02 Excavating
- C. Section 3.04 Finish Grading
- D. Section 6.02 Asphaltic Concrete Pavement
- E. Section 6.03 Portland Cement Concrete Pavement

1.03 APPLICABLE SPECIFICATIONS

“Standard Specifications For Road and Bridge Construction”, Latest Revision, Tennessee Department of Transportation (TDOT).

1.04 APPLICABLE REFERENCES

“American Association of State Highway and Transportation Officials” (AASHTO).

“American Society for Testing and Materials” (ASTM)

PART 2 – PRODUCTS

2.01 GENERAL REQUIREMENTS FOR MINERAL AGGREGATE BASE MATERIALS

- A. Mineral Aggregate shall meet the general requirements of TDOT Standard Specifications Section 303 and Subsection 903.05 for Class A or Class B aggregates depending upon whether type A or type B is required in the construction. Type A

base will require the use of Class A aggregate grading D. Either Class A or Class B aggregate may be used for type B base.

1. When the stationary plant method for mixing is used the aggregate will be accepted for gradation immediately following mixing or immediately prior to mixing based on periodic samples taken from the pugmill output or from the belt feeding the pugmill.
 2. When two (2) or more materials are blended on the road by means or mechanical mixers the aggregate will be accepted for gradation after mixing and before compaction based on samples taken from each layer of base material. Aggregate that does not require blending will be accepted for gradation at the aggregate production plant based on samples taken from stockpiles of plant production immediately prior to delivery to the road.
- B. Calcium chloride shall meet the requirements in TDOT Standard Specifications Subsection 921.02 for type 1, type 2, or calcium chloride liquor.
- C. Sodium chloride shall meet the requirements in TDOT Standard Specifications.

2.02 PORTLAND CEMENT CONCRETE BASE

- A. Portland Cement Concrete Base shall meet all requirements of TDOT Standard Specifications Section 306 and related materials specifications in Subsections 901.01, 903.01, 903.03, 907, 913, 921.01, 921.06.
- B. The Engineer shall determine the specified thickness of the base materials and the proportions of materials that will produce a workable concrete with maximum design slump of 1 ½" per AASHTO T-119.

2.03 BITUMINOUS PLANT MIX BASE (HOT MIX)

- A. This base mix shall conform to the TDOT Standard Specifications Section 307 and Section 411 of these specifications.

2.04 AGGREGATE-CEMENT BASE

- A. Aggregate-cement base shall meet all requirements of TDOT Standard Specifications Section 309 and related materials specifications in subsections 302.03(b), 901.01, 903.05, 903.15, 903.05C, 904.03.
- B. The Engineer shall determine specified thickness, cement ratio and aggregate to be used for base.

2.05 AGGREGATE-LIME-FLY ASH BASE

- A. Aggregate-lime-fly ash stabilized base course shall meet all requirements of TDOT Standard Specifications Section 312 and related material specifications in Subsections 903.05, 904.03, 904.03, 921.01, and 921.04.

2.06 TREATED PERMEABLE BASE

- A. Treated permeable base composed of either a mixture of aggregate, Portland cement and water or a mixture of aggregate with asphalt binder shall meet all requirements of TDOT Standard Specifications Section 313 and related material specifications in subsections 901.01, 903.03, 903.06, 904.01, 913.05, 921.01.

2.07 SUBGRADE (LIME) TREATMENT

- A. Subgrade (lime) treatment shall meet all requirements of TDOT Standard Specifications Section 302 and related material specifications in subsection 904.01, 904.03, 921.04, and 921.01.
- B. This work shall consist of preparing the existing subgrade, distributing the specified percentage of lime, initial mixing, mellowing, final mixing, compacting, finishing and curing.

PART 3 – EXECUTION

3.01 GENERAL

- A. The project construction area shall be cleared as specified in Section 3.01.

3.02 SUBGRADE

- A. Prepare subgrade in reasonably close conformity with the lines and grades as shown of the Plans.
- B. Grade subgrade in a manner as to provide ready drainage of water from subgrade and maintain ditches and drains during construction.
- C. Compact the finished subgrade to not less than 100% of the maximum required density.
- D. If lime treatment is deemed necessary, the subgrade shall be prepared and constructed in accordance with TDOT Standard Specifications Subsections 302.05 through 302.13.

3.03 BASE

- A. Place one or more courses of aggregates, and additives if required, on a prepared subgrade in reasonably close conformity with the lines, grades, thickness, and typical cross sections shown on the Plans.
- B. Spread all base material while at optimum moisture content in layers of specified thickness and cross section.
- C. For compaction testing purposes, each completed layer will be divided into lots of not more than 10,000 square yards. If the construction area yields fewer than 3 sample lots, then the lot size shall be reduced to obtain 3 lots of approximately equal size.
- D. Five density test shall be performed on each lot.

END OF SECTION

SECTION 6.02

ASPHALTIC CONCRETE PAVEMENT

PART 1 – GENERAL

1.01 WORK INCLUDED

- A. This work shall consist of mixing, spreading, compacting, and finishing of bituminous pavements for base, leveling, and surface courses on roads in accordance with TDOT Standard Specifications and in conformity with the lines, grades, and cross sections shown on the plans.

1.02 RELATED WORK

- A. Section 3.01: Clearing
- B. Section 3.02: Excavation
- C. Section 3.04: Finish Grading
- D. Section 6.01: Base and Subgrade Treatment.

1.03 APPLICABLE SPECIFICATIONS

- A. “Standard Specifications for Road and Bridge Construction”, latest revision, Tennessee Department of Transportation (TDOT).

1.04 APPLICABLE REFERENCES

- A. “American Association of State Highway and Transportation Officials,” (AASHTO).
- B. “American Society for Testing and Materials (ASTM).”

PART 2 – PRODUCTS

2.01 GENERAL REQUIREMENTS FOR ALL MIXES

- A. The Engineer may require samples of aggregate, bituminous materials, or the plant mixed material for testing in an independent laboratory.
- B. All methods of sampling and testing will be in accordance with current AASHTO methods for use on highway materials.

2.02 GENERAL REQUIREMENTS FOR MINERAL AGGREGATE BASE

- A. Mineral Aggregate shall meet the general requirements of Section 303, additional requirements specified for each type and TDOT Standard Specifications Subsection 903.05 for Class A or Class B aggregates depending upon whether type A or type B is required in the construction. Type A base will require the use of Class A aggregate grading D. Either Class A or Class B aggregate may be used for type B base.
 - 1. When the stationary plant method for mixing is used the aggregate will be accepted for gradation immediately following mixing or immediately prior to mixing based on periodic samples taken from the pugmill output or from the belt feeding the pugmill.
 - 2. When two (2) or more materials are blended on the road by means of mechanical mixers the aggregate will be accepted for gradation after mixing and before compaction based on samples taken from each layer of base material. Aggregate that does not require blending will be accepted for gradation at the aggregate production plant based on samples taken from stockpiles of plant production immediately prior to delivery to the road.
- B. Calcium chloride shall meet the requirements in TDOT Standard Specifications Subsection 921.02 for type 1, type 2, or calcium chloride liquor.
- C. Sodium chloride shall meet the requirements in TDOT Standard Specifications.

2.03 GENERAL REQUIREMENTS FOR BITUMINOUS MIXING PLANTS

- A. Bituminous mixing plants, either batch or continuous, sufficiently equipped and coordinated to provide paving mixes in an amount necessary for orderly prosecution of the work and to:
 - 1. Produce a uniform mixture having complete and uniform coating of all aggregate and a uniform distribution of the bituminous material in the mix.
 - 2. A canvas cover, or cover of suitable material, to protect the mix during transit.
 - 3. Insulation, if required, so that the mix can be delivered to the paving machine at the specified temperature or not more than 25° F. less than the discharge temperature at the plant.

2.04 GENERAL REQUIREMENTS FOR BITUMINOUS PLANT MIX PAVEMENTS

- A. Do not produce bituminous mixed material when the surface on which the material to be placed is wet or otherwise unsuitable; the air temperature is below 40 degrees F.; or when other conditions would prevent the proper placing and compacting of the mix.
- B. Aggregates shall meet the applicable requirements in TDOT Standard Specifications Section 903.

- C. Mineral filler shall meet the requirements in TDOT Standard Specifications Subsection 903.16.
- D. Bituminous materials shall meet the applicable requirements in TDOT Standard Specifications Section 904.
- E. Chemical additive shall meet the requirements in TDOT Standard Specifications Subsection 921.06.
- F. Aggregate shall be separated into coarse and fine aggregate stockpiles. When coarse aggregate is stockpiled by means causing segregation it shall be separated into coarse and medium coarse stockpiles.
- G. Each size and type of aggregate shall be stocked in a separate pile, bin, or stall. The storage yard shall be maintained in an orderly condition with a walkway between stockpiles that are not separated by partitions. The stockpiles shall be readily accessible for sampling.
- H. The mineral aggregate will be conditionally accepted for quality in the stockpile at the producer's site. The bituminous material may be conditionally accepted at the asphalt terminal. Acceptance of the aggregate gradation and asphalt cement content shall be determined from hot bin samples or sample(s) taken from the completed mix at the asphalt plant after it has been loaded onto the trucks for transport to the project as specified herein.
- I. Where anti-stripping additive other than hydrated lime as described in TDOT Standard Specifications Subsection 921.06.B.1 and this Section is required it shall be added by approved on line blending equipment at the Contractor's mixing plant.

2.05 HOT MIX BITUMINOUS PLANT MIX BASE

- A. The material used in this construction shall conform to the requirements in TDOT Standard Specifications Subsections 903.06, 921.06, 904.01.
- B. The specific grading of aggregate to be used will be specified in the plans. Mineral aggregate, bituminous material and the plant mix will be accepted as provided for in TDOT Standard Specifications Subsection 411.03.
- C. The graduations of the coarse and fine fractions of aggregate shall be such that when combined in proper proportions the resultant mixture will meet one of the following grading(s), as specified:

Table 903.06-3
HOT PLANT MIX BASE COURSE
MIXTURE DESIGN RANGE OF GRADATIONS

Total Per Cent Passing, by Weight

Sieve Size	Grading A	Grading A-S	Grading A-CRL	Grading B
50 mm (2")	100	100	100	100
37.5 mm (1-1/2")	81-100	75-100	80-93	95-100
19 mm (3/4")	50-71	55-80	60-75	70-85
9.5 mm (3/8")	35-50	-	-	49-72
4.75 mm (No. 4)	24-36	7-11	12-16	34-51
2.36 mm (No. 8)	13-27	-	-	23-42
600 µm (No. 30)	7-17	-	-	11-22
300 µm (No. 50)	-	-	-	9-14
150 µm (No. 100)	0-10	0-6	0-4	4-10
75 µm (No. 200)	0-4.5	0-4.5	0-3.5	2.5-6.5

Table 903.06-4: Hot Plant Mix Leveling Course
Mixture Design Range of Gradations

Sieve Size	Total Percent passing, by Weight				
	Grading B-M	Grading BM2*	Grading C	Grading CW	Grading CS
1-1/4 inch	-	100	-	-	-
1 inch	100	-	-	-	-
3/4 inch	85-100	81-93	100	100	-
3/8 inch	59-79	57-73	70-90	75-100	100
No. 4	42-61	40-56	39-66	-	89-94
No. 8	29-47	28-43	23-47	43-67	53-77
No. 30	13-27	13-25	10-27	23-47	23-42
No. 50	7-20	9-19	8-15	-	-
No. 100	4-10	6-10	4-8	4-10	9-18
No. 200	0-6.5	2.5-6.5	2.5-6.5	2.5-6.5	6-13.5
*When using natural sand as the fine aggregate, limit it to a maximum amount of 20% by weight of the mineral aggregate.					

2.06 PRIME COAT

- A. Materials shall meet the requirements in TDOT Standard Specifications Subsections 903.13 and 904.03.
- B. Emulsified Asphalt, Grade AE-P shall meet the following requirements:
Table 904.03-1(a): Test Requirements for Emulsified Asphalt

	Minimum	Maximum
Viscosity, Saybolt Furol at 77° F.	10	50
Settlement at 5 days		5%
Sieve Test		0.10%
Distillation to 500° F.		
Distillate, by weight		55%
Oil Portion of Distillate		12%
Tests on Residue		
Float Test, 140° F., sec.	20	
Soluble in Trichloroethylene	97.5%	

The settlement test shall be waived if the emulsion is used in less than 5 days.

The emulsion shall be tested in accordance with AASHTO T-59, except:

1. Stone coating test: AASHTO T-59, except that the mixture of stone and emulsified asphalt shall be mixed vigorously for five minutes and then

immediately drenched with approximately twice its own volume of tap water at room temperature.

2. Solubility in Trichloroethylene, AASHTO T-44
3. Float test, AASHTO T-50, except delete section 3.2 and substitute section 8.7 of AASHTO T-59 for preparation of test specimen.

C. Cut-Black Asphalt: Grade RC-70 or RC-250 meeting the requirements of AASHTO M-81 or M-82 for the type and grade specified or selected.

D. Application temperature for the bituminous material:

RC-70	80° - 150° F
RC-250	100° - 175° F
AE - P	60° - 140° F

2.07 TACK COAT

A. Bituminous materials shall conform to the requirements in TDOT Standard Specifications Subsections 904.01 through 904.03.

B. Emulsified Asphalt:

1. Amionic Emulsified Asphalts shall conform to all the requirements of AASHTO M-140 for the type and grade specified.
2. Grade AE-3 shall meet the following requirements:

	Minimum	Maximum
Viscosity, Saybolt Furol at 122° F.	50+	50 & pumpable
Settlement at 5 days		5%
Sieve Test		0.10%
Stone Coating	90%	
Distillation to 500° F.		
Distillate, by weight		30%
Oil Portion of Distillate		6%
Tests on Residue		
Float Test, 140° F., sec.	200	
Ductility, 77° F., cm.	40	
Soluble in Trichloroethylene	97.5%	
Ash by ignition		2

C. Cut-Back Asphalt: Grade RC-70 or RC-250 meeting the requirements of AASHTO M-81 or M-82 for the type and grade specified or selected.

D. Application temperature for the bituminous materials:

RC-70	80° F - 150° F
RC-250	100° F - 175° F
SS-1	60° F - 140° F

2.08 DOUBLE BITUMINOUS SURFACE TREATMENT

- A. Double Bituminous Surface Treatment shall conform to TDOT Standard Specification Subsection 405.06.
- B. Materials used in this construction shall meet the requirements in TDOT Standard Specifications Subsections 903.14, 903.22, 904.03.
- C. The ranges of application temperature in degrees Fahrenheit shall be as shown in TDOT Standard Specifications Subsection 404.02.

RC-800	175° - 250° F
RC-3000	200° - 275° F
RS-2	125° - 185° F
- D. Bituminous material shall be applied only when the designated surface is dry, firm and properly cured; only between April 15th and October 1, and when the ambient temperature in the in the shade and away from artificial heat is 70° F or above.

2.09 BITUMINOUS SEAL COAT

- A. Materials used in this construction shall meet the requirements in TDOT Standard Specifications Subsections 903.13 and 904.01 through 904.03.
- B. Application temperatures for bituminous materials in degrees Fahrenheit shall be shown in TDOT Standard Specifications Subsection 405.02.

2.10 ASPHALTIC CONCRETE SURFACE (HOT MIX)

- A. Materials used in this construction shall meet the requirements in TDOT Standard Specifications Subsections 903.11, 903.16, 904.01.
- B. The mineral aggregate, bituminous material, and plant mix will be accepted as provided for in TDOT Standard Specifications Subsection 407.02.

PART 3 – EXECUTION

3.01 GENERAL REQUIREMENTS

- A. Obtain approval of Engineer for the mix and surface to be treated prior to placing any materials.
- B. Protect all adjacent trees, surfaces, and structures from the bituminous material during construction.

- C. Prepare all receiving surfaces in reasonably close conformity with the lines, grades, and cross sections shown on the drawings.

3.02 MINERAL AGGREGATE BASE

Mineral aggregate base shall conform in general construction requirements, mixing, spreading, shaping and compaction, maintenance, thickness requirements, and surface requirements to the requirements in TDOT Standard Specifications Subsections 303.06 through 303.12.

3.03 BITUMINOUS PLANT MIX BASE (HOT MIX)

Bituminous plant mix base (hot mix) shall conform in composition of mixtures, general construction requirements, preparation of subgrade, sub-base, or surface, and thickness and surface requirement to the requirements in TDOT Standard Specifications Subsections 307.03 and 307.05 through 307.07.

3.04 PRIME COAT

Prime coat shall conform in limitations, preparation of surface, application of prime, application of cover material, and maintenance and protection to the requirements in TDOT Standard Specifications Subsections 402.04 through 402.08.

3.05 TACK COAT

Tack coat shall conform in preparation of surface and application of bituminous material to the requirements in TDOT Standard Specifications Subsections 403.04 and 403.05.

3.06 DOUBLE BITUMINOUS SURFACE TREATMENT

Double bituminous surface treatment shall conform in limitations, preparing designated surface, applications of bituminous material and mineral aggregate, rolling and curing, shoulders, and maintenance and protection to the requirements in TDOT Standard Specifications Subsections 405.06 through 405.09.

3.07 BITUMINOUS SEAL COAT

Bituminous seal coat shall conform in limitations, preparing the designated surface, application of bituminous material, spreading and rolling aggregate, shoulders, and maintenance and protection to the requirements in TDOT Standard Specifications Subsections 405.04 through 405.09.

3.08 BITUMINOUS PLANT MIX PAVEMENT (GENERAL)

Bituminous plant mix base (hot mix) shall conform in composition of mixtures (includes Contractor's quality control system), weather limitations, conditioning of existing surface, preparation of bituminous material, preparation of aggregates, mixing, spreading and samples, and surface requirements to the requirements in TDOT Standard Specifications Subsections 407.03 and 407.09 through 407.18.

3.09 ASPHALTIC CONCRETE SURFACE (HOT MIX)

Asphaltic concrete surface (hot mix) shall conform in composition of mixtures, general construction requirements, preparing the designated surface, mixing and surface requirements to the requirements in TDOT Standard Specifications Subsections 411.03 and 411.05 through 411.08 and 407.18.

3.10 COLD PLANING OF BITUMINOUS PLANT MIX PAVEMENTS

Cold planing of bituminous plant mix pavements shall conform in general requirements and surface requirements to the requirements in TDOT Standard Specifications Subsections 415.03 and 415.04.

3.11 PAVEMENT REPAIR

Where trenches have been opened in any roadway or street that is a part of the State highway system surfaces shall be restored in accordance with the requirements of the Tennessee Department of Transportation. All other restoration shall be done in accordance with this Section and Standard details.

- A. Excavation in the pavement area shall require that pavement surfaces be cut and brought to a neat line by use of an air hammer, saw, or other suitable equipment.
- B. Upon completion of installation of utility backfill, fill the trench with mineral aggregate type A, grading D (crusher run stone) and temporary asphalt patch with two (2) inches of cold mix or hot bituminous seal coat until such time that the permanent pavement patch is constructed.
- C. Complete the pavement restoration for the various types of roadway typical sections in conformance with Standard details and this Section.
- D. Concrete curb or combined curb and gutter, driveways, median pavement, and sidewalks shall be restored as required to match existing construction. Replace damaged sections with complete new sections or squares. Patching of damaged sections will not be permitted.
- E. Maintain restored sections and surfaces for a period of one (1) year following the date of final acceptance.

- F. The minimum width to be trimmed on each side of the trench line as seen in the section may be waived or amended upon approval of the Inspector however a minimum width of replacement shall be four (4) feet to allow for a roller.
- G. All excavations made within public right-of-way will require excavation and street closure permits from the Town of Chapel Hill prior to commencing Work.
- H. Flowable fill shall meet the requirements in TDOT Standard Specifications Section 204.06B.
- I. When a manhole top or other utility casting requires adjustment to an elevation one (1) inch or more above the existing pavement grade and is exposed to traffic before final paving is completed a temporary ramp shall be constructed by feathering bituminous concrete for three hundred sixty (360) degrees around the manhole or utility casting. A taper slope of not less than two (2) feet per one (1) inch shall be used. During the paving operation but prior to the placement of the topping course the bituminous concrete taper shall be removed from around the manhole to a minimum depth of one (1) inch below the top of the manhole.

END OF SECTION

SECTION 6.03

PORTLAND CEMENT CONCRETE PAVEMENT

PART 1 – GENERAL

1.01 WORK INCLUDED

- A. This work shall consist of constructing a pavement or Portland cement concrete with reinforcement as specified on a prepared surface in accordance with the TDOT Standard Specifications and in conformity with the lines, grades and cross section show on the plans.

1.02 RELATED WORK

- A. Section 3.01: Clearing.
- B. Section 3.02: Excavation.
- C. Section 3.04: Finish Grading.
- D. Section 6.01: Base and Subgrade Treatment.

1.03 APPLICABLE SPECIFICATIONS

- A. “Standard Specifications for Road and Bridge Construction”, latest revision, Tennessee Department of Transportation (TDOT).

1.04 APPLICABLE REFERENCES

- A. “American Association of State Highways and Transportation Officials” (AASHTO).
- B. “American Society for Testing and Materials” (ASTM).

PART 2 – PRODUCTS

- A. All concrete used shall be in accordance with TDOT Standard Specifications Section 501.
 - 1. Minimum compressive strength shall be 3000 psi when tested according to AASHTO T-22.
 - 2. Minimum flexural strength shall be 550 psi when tested according to AASHTO T-97 or 650 psi when tested according to AASHTO T-177.
 - 3. Slump shall be between ½” and 2”.

- B. All steel dowels shall be epoxy coated and of size and length indicated on the Plans and in accordance with TDOT Standard Specifications and Standard Drawings.

PART 3 – EXECUTION

3.01 PREPARATION OF BASE

- A. Construct or correct the base to such grade tolerances as will insure the concrete pavement thickness required in accordance with TDOT Standard Specifications Part 3 – Base and Subgrade Treatments.
- B. Complete base work not less than 500 linear feet in advance of paving.
- C. The base grading machine and slip-form paver shall be equipped with automatic line guidance and grade control.

3.02 FORMWORK

- A. All formwork shall conform in base support, form setting, grade and alignment with TDOT Standard Specifications Subsection 501.07.

3.03 RETEMPERING

- A. The retempering of concrete which has partially hardened by the addition of any ingredient will not be permitted; however a portion of the mixing water may be withheld from transit mixers and added at the work site.

3.04 CONCRETE PAVING

- A. The placing of concrete shall conform in unloading, spreading, consolidating, and requirements of slip-form method as detailed in TDOT Standard Specifications Subsection 501.12.

3.05 JOINTS

- A. Joints shall be constructed of the type and dimensions and at the location required by the Plans and in accordance with the provisions of TDOT Standard Specification Subsection 501.15.

3.06 CURING

- A. Curing shall be performed in accordance with TDOT Standard Specification Subsection 501.18.

3.07 FINAL STRIKE-OFF, CONSOLIDATION AND FINISHING

- A. Final strike-off, consolidation and finishing shall conform with TDOT Standard Specification Subsection 501.16.

3.08 TESTING

- A. All placed concrete shall be tested in accordance with TDOT Standard Specification Section 501.13.

3.09 DEFECTIVE INSTALLATION

- A. Where surface deviations exceed ½ inch in 12 feet, remove and replace the pavement.
- B. When it is necessary to remove pavement, remove and replace any remaining portion of the slab adjacent to the joints that is less than 10 feet in any length.

END OF SECTION

SECTION 6.04

HIGHWAY SIGNING

PART 1 – GENERAL

1.01 WORK INCLUDED

- A. Highway signing shall consist of the construction of foundations and supports, fabricating, furnishing, assembling, and erecting traffic signs on the supports, including delineators when specified, for a section of highway, its interchanges, frontage roads and roads or streets affording immediate access to the highway.
- B. Highway signs and devices shall be constructed and erected in accordance with these Specifications and the Manual on Uniform Traffic Control Devices (MUTCD), FHWA latest edition, at the locations and within reasonably close conformity to the lines and grades indicated on the Plans or as otherwise directed by the Engineer.
- C. This work shall be in accordance with TDOT Standard Specifications Section 713 and 916.

1.02 APPLICABLE SPECIFICATIONS

- A. “Standard Specifications for Road and Bridge Construction,” Latest Edition, Tennessee Department of Transportation (TDOT).
- B. “Standard Specifications for Structural Supports for Highway signs, Luminaires and Traffic Signals,” Current Edition, American Association of State Highway and Transportation Officials (AASHTO).

1.03 APPLICABLE REFERENCES

- A. “Manual on Uniform Traffic Control Devices for Streets and Highways,” (MUTCD) Current Edition, Federal Highway Administration (FHWA).
- B. “Standard Highway Signs,” Current Edition, Federal Highway Administration (FHWA).
- C. “Roadside Design Guide,” Current Edition, American Association of State Highway and Transportation Officials (AASHTO).

PART 2 – PRODUCTS

2.01 ALUMINUM

- A. Aluminum signs shall conform to TDOT Standard Specifications Section 713 and subsection 916.02
- B. The aluminum sign blanks shall be flat and shall contain no visible lateral bow.
- C. The size of signs shall be shown on the Plans or conform to standard sizes as identified in the MUTCD.

2.02 STEEL

- A. Steel signs shall conform to TDOT Standard Specifications Section 713 and Subsection 916.03.

2.03 STAINLESS STEEL

- A. Stainless steel signs shall conform to TDOT Standard Specifications Subsection 916.04.

2.04 REFLECTIVE SHEETING

- A. Reflective sheeting shall conform to TDOT Standard Specification Subsection 916.06 and meet all requirements of AASHTO M268.
- B. All sign colors shall conform to the current edition of the MUTCD.

2.05 FABRICATION

- A. Fabrication of all signs and supports shall be in accordance with the details shown on the Plans and in conformance with TDOT Standard Specifications Subsection 916.05.
- B. All signs shall conform to the current edition of the MUTCD and other referenced documents cited by the MUTCD.

2.06 SIGN SUPPORTS

- A. Type, length and size of post shall be shown on the Plans.
- B. All posts for ground mounted signs shall conform to AASHTO Standard Specifications.

- C. All posts shall be driven into the ground or bolted to a stub in the concrete foundation.
- D. Posts shall be plumb, aligned and oriented as shown on the Plans.
- E. In driving posts, a method shall be used which will not damage or deface the top of the post.
- F. Post shall be one of the following (refer to TDOT Standard Drawing T-S-19):
 - 1. Perforated/Knockout Tube: ASTM A446 (Grade A) or A570.
 - 2. U-Post: ASTM A499
 - 3. Ribbed U-Post: ASTM A499

PART 3 – EXECUTION

3.01 ERECTION

- A. Construct highway signs and devices in accordance with the “Manual on Uniform Traffic Control Devices,” (MUTCD), FHWA, Current Edition.
- B. Construct signs at the locations and within reasonably close conformity to the lines and grades indicated on the Plans or otherwise directed by the Engineer.

END OF SECTION

SECTION 6.05

PAVEMENT MARKINGS

PART 1 – GENERAL

1.01 WORK INCLUDED

- A. This work shall consist of furnishing and supplying pavement markings in accordance with these specifications, the latest revision of the “Manual on Uniform Traffic Control Devices,” (MUTCD) published by the FHWA, and in reasonably close conformity to the lines, dimensions, patterns, locations, and details shown on the Plans or established by the Engineer.
- B. This work shall be in accordance with TDOT Standard Specifications Section 716.

1.02 APPLICABLE SPECIFICATIONS

- A. “Standard Specifications for Road and Bridge Construction,” Latest Revision, Tennessee Department of Transportation (TDOT).

1.03 APPLICABLE REFERENCES

- A. “Manual on Uniform Traffic Control Devices,” (MUTCD) Current Edition, Federal Highway Administration (FHWA).

PART 2 – PRODUCTS

2.01 THERMOPLASTIC PAVEMENT MARKING

- A. Thermoplastic pavement markings shall conform to all requirements set forth by TDOT Standard Specifications Subsections 716.03 and 919.01.
- B. The pavement temperature shall be a minimum of 50° F and rising before application begins.

2.02 PREFORMED PLASTIC PAVEMENT MARKINGS

- A. Preformed plastic pavement marking shall conform to all requirements set forth by TDOT Standard Specifications Subsection 716.06 and 919.03.
- B. The pavement temperature shall be a minimum of 60° F or over before application begins.

2.03 PAINT

- A. Paint shall be applied in conformance with all requirements set forth by TDOT Standard Specifications Subsections 716.07, 910.01, and 910.02.
- B. When reflectorized paint is required for temporary or final marking, the paint shall be installed to permanent standards at the end of each day's work.

2.04 RAISED REFLECTIVE PAVEMENT MARKERS

- A. Markers shall conform to all the requirements set forth by TDOT Standard Specifications Subsections 716.04, and 919.04.
- B. The markers shall be installed when the pavement is dry and the pavement temperature is no less than 50° F.

PART 3 – EXECUTION

- 3.01 All pavement markings shall be in accordance with the "Manual on Uniform Traffic Control Devices," (MUTCD), published by FHWA.
- 3.02 All pavement markings shall be in close conformity to the lines, dimensions, patterns, locations, and details shown on the Plans.

END OF SECTION

SECTION 6.06

GUARDRAIL

PART 1 – GENERAL

1.01 WORK INCLUDED

- A. This work shall consist of furnishing and erecting guardrail, and the construction of anchor blocks and approach ends, of the specified kind and dimensions, in accordance with these Specification, and in reasonably close conformity with the lines, grades and locations shown on the Plans, or as directed by the Engineer.
- B. Guardrail shall include appurtenant materials and work in making connections with other guardrail or structures, as may be required to complete the construction as indicated on the Plans.
- C. This work shall be in accordance with TDOT Standard Specifications Section 705 and 909.

1.02 APPLICABLE SPECIFICATIONS

- A. “Standard Specifications for Road and Bridge Construction,” Latest Revision, Tennessee Department of Transportation (TDOT).

1.03 APPLICABLE REFERENCES

- A. “Roadside Design Guide,” Current Edition, American Association of State Highway and Transportation Officials (AASHTO).
- B. “American Society for Testing and Materials (ASTM)”..

PART 2 – PRODUCTS

2.01 Metal Beam Guardrail

- A. Corrugated sheet steel beams shall conform to the current requirements of AASHTO M180, Class A, Type 2. Rail material shall have a yield strength of 50 KIPS per square inch and a tensile strength of 70 KIPS per square inch.
- B. Rub rails and rub rail splice plates shall conform to ASTM A36 and shall be galvanized in accordance with ASTM A123.
- C. Where guardrail is to be placed on a curve with a radius less than 150 feet, the rail section shall be shop-formed to the required radius.

2.02 Guardrail Posts and Block-Outs

- A. Posts and block-outs shall be of timber with a stress grade of 1200 psi or more. Posts will have nominal size of 6" x 8". Block-outs will have nominal size of 6" x 8" (typical size 5.5" x 7.5"). Testing shall be in accordance with West Coast Lumber Inspection Bureau, Southern Pine Inspection Bureau, or other appropriate timber associations. Timber for posts shall be rough sawn (unplanned) with nominal dimensions indicated. Timber for block-outs shall be S4S with the typical dimensions indicated
- B. All wood posts and block-outs shall be treated with timber preservative as required by subsection 911.02 of the TDOT Standard Specifications.
- C. Wood posts and block-outs shall be furnished with holes for future rail adjustment in accordance with details shown on TDOT Standard Drawings S-GR-13.
- D. Materials and specifications not shown in the "S-GR" series of TDOT Standard Drawings shall be in accordance with standard provisions regarding section 705.
- E. The contractor may have optional choice of either the steel W6 x 8.5 or W6 x 9.0 hot rolled or welded steel shape, or the wood posts with their companion block-outs as shown above, within the following stipulations:
 - 1. The mixing of any of the above post types on a given project will be avoided if possible.
 - 2. Should it become necessary to change the type of posts on a given project, the posts shall not be mixed on any given run of guardrail. (Exception, wood posts on guardrail terminals.)
- F. On existing structures not having a vertical face for the attachment of two rail elements, use of the W6 x 15.0 posts is required on the semi-rigid to rigid barrier transition details, see TDOT Standard Drawings S-GR-16 and S-GR-20. The bolt holes will be oriented to the center line of the flange of the steel post and will be the same size and dimension as those shown on TDOT Standard Drawings S-GR-13.
- G. Metal posts and all block-outs shall be furnished with holes for future rail adjustment in accordance with details shown on TDOT Standard Drawings S-GR-13 and S-GR-13A.
- H. W6 x 9.0 or W6 x 8.5 post shall be used for installations on bridges as shown on TDOT Standard Drawing S-GR-22.
- I. Welded steel posts may be used as alternates to the hot rolled steel shape. They must conform to ASTM A769 and be galvanized according to ASTM A123.

2.03 GUARDRAIL HARDWARE

- A. Bolts shall conform to the requirements of ASTM A307 and nuts to the requirements of ASTM A563M, Grade "A" or better.
- B. All steel fittings, bolts, washers and other accessories shall be galvanized in accordance with the requirements of AASHTO M 111 or ASTM A153, whichever may apply. All galvanizing shall be done after fabrication.

2.04 TERMINALS

- A. Type and installation of terminals shall conform to TDOT Standard Specifications and Standard Drawings.

2.05 DIMENSIONS

- A. All dimensions shall be in accordance with TDOT Standard Drawings.

PART 3 – EXECUTION

All work shall be completed in accordance with TDOT Standard Specifications Subsection 705.04 through 705.08 and applicable Standard Drawings.

END OF SECTION

SECTION 6.07

CONCRETE CURBS, GUTTERS, SIDEWALKS, AND DRIVEWAYS

PART 1 – GENERAL

1.01 WORK INCLUDED

- A. This work shall consist of curb, gutter, combined curb and gutter, and sidewalk construction of portland cement concrete in accordance with TDOT Standard Specification Section 701 and 702 and this document and in reasonably close conformity with the lines, grades, typical cross sections and dimensions shown in the plans.

1.02 RELATED WORK

- A. Section 3.01: Clearing
- B. Section 3.02: Excavation
- C. Section 3.04: Finish Grading
- D. Section 6.01: Base and Subgrade Treatment
- E. Section 6.02: Asphaltic Concrete Pavement
- F. Section 6.03: Portland Cement Concrete Pavement

1.03 APPLICABLE SPECIFICATIONS

“Standard Specifications for Road and Bridge Construction”, Latest Revision, Tennessee Department of Transportation (TDOT).

1.04 APPLICABLE REFERENCES

“American Association of State Highway and Transportation Officials” (AASHTO).

“American Society for Testing and Materials” (ASTM).

“American Concrete Institute” (ACI).

“Americans with Disabilities Act” (ADA).

“Americans with Disabilities Act Accessibility Guidelines” (ADAAG).

“Architectural Barriers Act” (ABA).

PART 2 – PRODUCTS

2.01 GENERAL REQUIREMENTS

Materials shall meet the applicable requirements in TDOT Standard Specifications Sections 604 and 913 together with the conditions and requirements set forth in this Section.

2.02 PREFORMED JOINT FILLER

Prefomed joint filler shall conform to the requirements in TDOT Standard Specifications Subsection 905.01. Joint filler for brick sidewalk shall be Portland cement with prepared color added conforming to ASTM C 150. Sand shall conform to ASTM C 144.

2.03 DRAIN PIPE

- A. This pipe shall conform to AASHTO M 178 or AASHTO M 179 for the specified material and diameters. Unless otherwise specified the pipe shall be of standard quality class. When specified the pipe spigot shall have integral spacer lugs to provide for an annular opening and self centering feature.
- B. Drain pipe shall conform to the requirements in TDOT Standard Specifications Subsection 914.04.

2.04 CONCRETE

Concrete for sidewalks, driveways, and median pavement shall be Class A concrete meeting all the requirements prescribed in TDOT Standard Specifications Section 604.

- A. When the use of a curb machine is authorized the Contractor may request a concrete design based on the following:

<u>Water</u>	<u>Cement</u>	<u>Combined Coarse and Fine Aggregate</u>
4 gallons (maximum) coarse aggregate fine aggregate	94 lbs.	505 lbs. size nos. 7, 57, 67, 78 45% to 60%

- B. Entrained air will not be required in curb concrete made with the above combination.
- C. The water and percentages of fine and coarse aggregate may be adjusted within the above limits to permit satisfactory placement.
- D. Compressive test specimens may be made by the vibratory method in accordance with AASHTO T-23 or other approved methods.

2.05 BRICK

Brick when made from clay or shale shall conform to ASTM 902 including BX for dimensional tolerance. When made of concrete they shall conform to ASTM C 55. The kind and grade shall be as specified in the plans. Brick shall be full depth two and one-quarter (2 1/4) inches thick and shall be four inches by eight inches (4" x 8") in area unless otherwise shown in the plans or directed by the Engineer. Contractor shall submit sample for approval.

2.06 ASPHALT

Setting bed for brick sidewalk shall be a three-quarter (3/4) nominal inch deep binder mix and binder base shall be a four (4) inch deep binder mix both conforming to the applicable requirements in TDOT Standard Specifications Sections 307 and 407. Contractor shall determine the exact proportions to produce the best possible mixture for construction of the bituminous setting bed and binder base to meet construction requirements and shall submit design mix to the Engineer for approval.

2.07 NEOPRENE MODIFIED ASPHALT ADHESIVE

Neoprene modified asphalt adhesive under brick shall conform to the following specifications "or equal":

mastic (asphalt adhesive)

solids (base)	75% ± 1%
pounds/gallon	8 lbs. – 8.5 lbs.
solvent mineral spirits (over 100° Fahrenheit flash)	

base (2% neoprene, 10% asbestos-free fibers, 88% asphalt)

melting point – ASTM D 36	150° Fahrenheit mix
penetration – 77° Fahrenheit 100 gram load 5 sec.	23-27
ductility – ASTM D 113-44 at 77° Fahrenheit	
2 inches/min.	39-49 inches/min.

2.08 MORTAR

Cement and sand used for preparation of mortar shall conform to the requirements in TDOT Standard Specifications Subsection 905.02.

PART 3 – EXECUTION

3.01 GENERAL

Curbs, gutter, combined curb and gutter, sidewalks, and ramps shall meet all applicable requirements of the ADA, ADAAG and ABA.

3.02 PRELIMINARY WORK

Clearing and grubbing, removal of structures and obstructions, excavation and undercutting, and embankment construction shall be performed in accordance with the provisions in TDOT Standard Specifications Sections 201, 202, 203, and 205 and in Section 3.01: Clearing, Section 3.02: Excavation and Section 3.04: Finish Grading.

3.03 SUBGRADE PREPARATION

Subgrade preparation for sidewalks, driveways, and median pavement shall be made to the required depth and to a width that will permit the installation and bracing of the forms. The subgrade shall be shaped and compacted to a firm even surface in reasonably close conformity with the grade and cross section shown in the plans. All soft and yielding material shall be removed and replaced with acceptable material which shall then be compacted as directed.

3.04 EXPANSION JOINTS

- A. Expansion joints for curb, gutter, or curb and gutter shall be formed at the intervals and locations shown in the plans using preformed filler three-quarters (3/4) inch thick unless otherwise specified. They shall be placed in line with corresponding expansion joints in adjoining pavement or other construction. Joint filler shall be cut to the full cross section of the curb, gutter, or curb and gutter.
- B. For sidewalks and driveways, unless otherwise indicated in the plans premolded expansion joint filler one-half (1/2) inch in thickness shall be placed at locations and in line with expansion joints in the adjoining pavement, gutter, or curb. All premolded expansion joint filler shall be cut to full width or length of the proposed construction and shall extend to within one-half (1/2) inch of the top or finished surface. All longitudinal expansion joints shall be placed as indicated in the plans. All expansion joints shall be true, even, and present a satisfactory appearance.
- C. Construction joints shall be formed around all appurtenances such as manholes, utility poles, etc., extending into and through the sidewalk or median area. Premolded expansion joint filler one-half (1/2) inch thick shall be installed in these joints. Expansion joint filler of the thickness indicated shall be installed between concrete sidewalks and any fixed structure such as building or bridge. One-half (1/2) inch thick expansion joint filler shall be installed between concrete curb and median pavement and unless otherwise specified between concrete curb and sidewalk. This expansion joint material shall extend for the full depth of the walk or median pavement.

3.05 LIMITATIONS OF MIXING

Limitations on the mixing of concrete shall be as prescribed in TDOT Standard Specifications Subsections 604.13.

3.06 MIXING CONCRETE

Concrete shall be mixed in accordance with the provisions in TDOT Standard Specifications Subsection 604.03.

3.07 PLACING CONCRETE

- A. Placing concrete shall be performed as provided for in TDOT Standard Specifications Subsection 501.12 except that mechanical spreaders will not be required. Immediately before placing the concrete, the subgrade shall be thoroughly wetted and the forms given a coating of light oil. The forms shall be thoroughly cleaned and oiled each time before using.
- B. The concrete shall be placed immediately after mixing. The edges, sides, or faces shall be thoroughly spaded and vibrated sufficiently to consolidate the concrete thoroughly and bring the mortar to the surface after which the surface shall be finished smooth and even by means of a wooden float.
- C. Concrete curb, gutter, and combined curb and gutter shall be constructed reasonably true to line, grade, and cross section and unless otherwise specified in the plans in sections having uniform lengths of ten (10) feet. The length of these sections may be reduced where necessary for closures but not section less than six (6) feet will be permitted. The templates shall be set carefully before the placing of the concrete and allowed to remain in place until the concrete has set sufficiently to hold its shape but shall be removed while the forms are still in place. The forms on the face of all curbs shall be removed as soon as the concrete will hold its shape and the surface then floated with a wooden float to a smooth and even finish. No plastering will be permitted. Unless otherwise specified the top edges of the curb and the edge of the gutter shall be rounded to a radius as shown on the standard drawings and the edges on each side of templates and expansion joint material shall be finished with an edging tool with a radius of not over one-quarter (1/4) inch and then all lines or marks shall be removed with a wet brush. The back of curbs shall be finished not less than three (3) inches below the top of backfill against the curb. Any exposed surface or surfaces against which some rigid type of construction is to be made shall be left smooth and uniform so as to permit free movement of the curb, gutter, or combined curb and gutter.
- D. Sidewalks shall be constructed with materials which produce one of the following results:
 - 1. standard portland cement concrete (white concrete) with a coarse broomed finish.
 - 2. portland cement concrete containing river gravel to produce an exposed aggregate finish.
 - 3. brick sidewalk.

- E. Joints shall be constructed at intervals of twenty-five (25) feet to thirty (30) feet except for closures but no interval less than six (6) feet will be permitted.
- F. A four (4) feet wide grass area furnishing zone adjacent to curb shall be provided for placement of light standards, poles, fire hydrants, mailboxes, etc.
- G. A minimum three (3) feet wide clearance shall be provided through the path of travel.
- H. Where a grass area furnishing zone is not provided a maximum two (2) feet wide furnishing zone adjacent to curb shall be provided maintaining a minimum three (3) feet clearance through the path of travel.
- I. Ramps (curb and driveway) shall be constructed to the dimensions and finished elevations as specified in the plans or Contract Documents and shall also conform to the requirements of the ADA, ADAAG, and ABA. Surface of ramp shall be stable, firm, and slip resistant. Surface texture of ramp shall be that obtained by a coarse brooming transverse to the slope of the ramp. Ramps shall not be constructed using brick or an exposed aggregate concrete finish and shall not contain longitudinal or transverse expansion joints or groves.
- J. Where existing sidewalks on ramps are to be removed for replacement or to permit other construction the limits of construction shall be considered as extending to the next existing joint marking beyond the normal limits or replacement and/or other construction.
- K. Where sidewalks are constructed adjacent to permanent structures or other rigid construction on one (1) side and curb on the other extend expansion joint of premolded material only along back at curb and place for the full depth of the slab. Place a premolded expansion joint between the sidewalk and adjacent curb at all crosswalks both public and private. Fasten premolded expansion joint filler to prevent displacement.
- L. Where sidewalk is constructed in conjunction with adjacent curb the expansion joints in the curb and sidewalk shall coincide. Where such construction is adjacent to existing curb the expansion joints shall if practicable coincide. Prior to placing concrete around any permanent structure place premolded expansion joint material around such structure for the full depth of the sidewalk.
- M. Where existing structures such as light standards, poles, fire hydrants, etc., are within the limits of the sidewalk area place premolded expansion joint around the structure for the full depth of the concrete.

3.08 FINISHING CONCRETE

- A. The concrete shall be struck off with a transverse template resting upon the side forms. After the concrete has been struck off to the required cross section it shall be finished with floats and straight edges until the required surface requirements have been obtained.
- B. All tool marks shall be removed with a wetted brush or wooden float and the finished surface shall present a uniform and pleasing appearance.
- C. When the use of curb machines is permitted finishing shall be performed as specified above except that contraction joints may be sawed a minimum depth of one-quarter (1/4) the thickness of the section at intervals not less than six (6) feet nor more than ten (10) feet in lieu of constructing the curbs in sections.
- D. Weep holes or drainage opening shall be placed through curbs as indicated in the plans or as directed by the Engineer and coarse aggregate shall be placed behind each opening as needed.
- E. When the surface of the concrete is free from water and just before the concrete obtains its initial set it shall be finished and swept lightly with a broom in order to produce a sandy texture. The longitudinal surface variations shall be not more than one-quarter (1/4) inch under a twelve (12) foot straightedge nor more than one-eighth (1/8) inch on a five (5) foot transverse section. The surface of the concrete shall be so finished as to drain completely at all times.
- F. The edges of the sidewalks, driveways, and median pavement shall be carefully finished and rounded with an edging tool having a radius of one-half (1/2) inch.
- G. The surface of sidewalks shall be divided into blocks by the use of a grooving tool. The grooves shall be spaced approximately five (5) feet apart and the blocks shall be rectangular unless otherwise ordered by the Engineer. The grooves shall be cut to a depth of not less than one (1) inch. The edges of the grooves shall be edged with an edging tool having a radius of one-quarter (1/4) inch.
- H. Unless otherwise indicated in the plans marks or grooves may be placed at right angles to the center line of driveways and approximately eight (8) inches apart. These marking shall be between one-eighth (1/8) inch to one-quarter (1/4) inch in depth and shall be made with a suitable marking tool. A grooving tool six (6) inches to eight (8) inches apart may be used. Any irregularities caused by the edges of the marking tool shall be removed by the use of a wetter brush or wooden float. All marking edges shall be rounded satisfactorily.
- I. Grooves shall not be placed in the surface of sidewalks or driveways reinforced for beam action where the full thickness of concrete is required for strength.

- J. The edges of the concrete at expansion joints shall be rounded with an edging tool having a radius of one-quarter (1/4) inch. All marks caused by edging shall be removed with a wetted brush or wooden float. The top and ends of expansion joint material shall be cleaned of all concrete and the expansion joint material shall be so trimmed as to be slightly below the surface of the concrete.

3.09 PROTECTION AND CURING

- A. Forms may be removed at any time that removal will not damage the concrete. No pressure shall be exerted upon the concrete in removing forms.
- B. Curing and protection during cold weather shall be performed as provided for in TDOT Standard Specifications Subsection 501.18
- C. Pedestrians will not be allowed upon concrete sidewalks or driveways until twelve (12) hours after finishing concrete and no vehicles or loads shall be permitted on any sidewalk or driveway until the Engineer has determined that the concrete has attained sufficient strength of such loads. An accessible alternative route(s) meeting the requirements of the ADA and approval of the Engineer shall be provided by the contractor.
- D. The Contractor shall construct and place such barricades and protection devices as are necessary to keep pedestrians and other traffic off the sidewalks or driveways. An accessible alternative route(s) meeting the requirements of the ADA and approval of the Engineer shall be provided by the Contractor.
- E. Any sidewalk or driveway damaged prior to final acceptance of the project shall be repaired at the Contractor's expense by removing concrete within groove limits and replacing it with concrete of the type and finish in the original construction.
- F. The Contractor shall protect the curb, gutter, and combined curb and gutter until finally accepted. Any concrete that is damaged during that period shall be repaired by removing and reconstructing each ten (10) foot section that has been damaged. This reconstruction shall be at the Contractor's expense.

3.10 BACKFILLING

Immediately after the concrete has set sufficiently and the forms have been removed and the spaces at the back of the curb or combined curb and gutter and along the edges of sidewalk or driveway shall be filled with suitable material. This material shall be placed in layers not exceeding four (4) inches in loose thickness and compacted until firm and stable.

3.11 BRICK SIDEWALK (GENERAL)

- A. Before beginning work on brick sidewalk all necessary clearing and grubbing, removal of structures and obstructions, excavation and undercutting, and

embankment construction shall be performed in accordance with the provisions in TDOT Standard Specifications Sections 201, 202, 203, and 205 and in Section 3.01-Clearing, Section 3.02-Excavation and Section, and Section 3.04-Finish Grading.

- B. Subgrade preparation for brick sidewalks shall be done in accordance with the provisions in Section 7.07 Subsection 3.03 of this document. The foundation for this type of construction shall present a uniform bearing surface and if a reinforced foundation is necessary it shall be constructed of Class A concrete in accordance with the applicable provisions and requirements set out in TDOT Standard Specifications Section 604.
- C. Brick sidewalk shall not be constructed in freezing weather nor when bricks contain frost.
- D. Brick for exposed surfaces, corners, etc., shall be selected from approved brick as to color and uniformity.
- E. All brick shall be thoroughly cleaned and well moistened with water immediately before being laid and the bed which is to receive the brick shall be thoroughly cleaned and well moistened with water before placing thereon.
- F. All brick laid in freshly made mortar shall be laid in a substantial and workmanlike manner and true to the lines and grades indicated in the plans or as directed by the Engineer.
- G. Care shall be taken to keep the exposed surface of brick free from mortar stains. Immediately after laying brick face shall be cleaned thoroughly of all mortar stains.
- H. In case any brick is moved, has settled, or the joints broken after laying the brick shall be taken up, the mortar thoroughly cleaned from the brick, bed, and joints, and the brick re-laid in fresh mortar.
- I. When brick is to be laid in sand it shall be laid with sand swept butt joints on a one-half (1/2) inch sand setting bed.
- J. When brick is to be laid on concrete the concrete shall be solid four (4) inch thick slab with 6-6-10-10- welded wire mesh reinforcing (if shown in plans or directed by Engineer). Punch holes for concrete slab shall be one (1) inch in diameter at twelve (12) inches center to center spacing each way.
- K. Prime concrete base with emulsified asphalt (RS-1 or CRS-1) if there is to be vehicular traffic over brick.
- L. After the modified asphalt adhesive is applied (if called for to be used in the plans or directed by the Engineer) carefully place brick by hand in straight courses with hand

tight joints and uniform top surface. Good alignment shall be kept and the pattern shall be that shown in the plans or directed by the Engineer.

- M. New brick and mortar shall match existing brick and mortar in color and size where integrating with existing sidewalks. Contractor shall submit samples of all brick to Engineer for approval.
- N. Brick sidewalk shall be protected and kept wet for a period of forty-eight (48) hours after laying brick.

3.12 PLACING BITUMINOUS SETTING BED FOR BRICK

To install the setting bed over the asphalt binder or concrete base surface place control bars directly over the base. The depth control bars shall be set carefully to bring the brick when laid to proper grade. Thickness of the finished setting bed shall be no more than one (1) inch or less than one-half (1/2) inch.

- A. The setting bed shall be rolled with a power roller to a nominal depth of three-quarter (3/4) inch. The thickness shall be adjusted so that when the brick is placed the top surface of the brick shall be at the required finished grade. However under no circumstances shall the setting bed exceed one (1) inch.
- B. A coating of two (2) percent neoprene modified asphalt adhesive shall be applied by squeegee or trowel over the top surface of the bituminous setting bed so as to provide a bond under the brick.
- C. After the modified asphalt adhesive is applied (if called for to be used in the plans or directed by the Engineer) carefully place the pavers by hand in straight courses with hand tight joints and uniform top surface. Good alignment shall be kept and the pattern shall be that shown in the plans or as directed by the Engineer.
- D. Hand tight joints shall read from zero (0) inches to maximum one-quarter (1/4) inch from brick. Sweep a dry mixture of one (1) part Portland cement to match color of brick and three (3) parts sand until joints are flush with top surface. Fog lightly with water. Joints may recede up to one-eighth (1/8) inch. Cement stains that remain should be cleaned. Screenings or other suitable fillers are also acceptable.
- E. Prime concrete or asphalt binder base with emulsified asphalt (RS-1 or CRS-1) if there is to be vehicular traffic over brick.

3.13 FINAL CLEANUP

Final cleanup shall be performed in accordance with the requirements in TDOT Standard Specifications Subsection 104.10 and in Section 3.08-Cleaning and Restoration.

END OF SECTION

SECTION 7.01
STORM DRAINAGE

PART 1 – GENERAL

1.01 WORK INCLUDED

- A. This work shall consist of the construction of pipe drains, pipe culverts, side drains, slope drains, underdrains, storm sewers catchbasins, inlets and pipe end walls of the type, dimensions, and locations as shown on the Plans.
- B. The construction shall be completed in accordance with these Specifications and TDOT Standard Specifications Section 607, 610, 611, and 710 and related material specifications in subsections 903.17, 905.02, 905.03, 912.01, 912.03, 914.01, 914.02, 914.03, and 915.02.
- C. The construction shall be in reasonably close conformity with the lines, grades, and cross sections shown on the Plans.

1.02 RELATED WORK

- A. Section 3.02: Excavation
- B. Section 3.08: Trenching, Backfilling and Compaction for Utilities
- C. Section 3.09: Boring
- D. Section 3.12: Concrete for Utilities
- E. Section 4.01: Manholes
- F. Section 4.02: Sanitary Sewers (Gravity)

1.03 APPLICABLE SPECIFICATIONS

“Standard Specifications for Road and Bridge Construction”, Latest Revisions, Tennessee Department of Transportation (TDOT).

1.04 APPLICABLE REFERENCES

“American Association of State Highway and Transportation Officials” (AASHTO).

“American Society for Testing and Materials” (ASTM).

PART 2 – PRODUCTS

2.01 GENERAL REQUIREMENTS FOR PIPE CULVERTS AND STORM SEWERS

- A. The sizes of all pipes shall be identified by the nominal inside diameter.
- B. Steel and aluminum pipe are considered an option for corrugated metal pipe, pipe arches and underdrains.
- C. Aluminum coating or bituminous coating may be used in place of paved or coated corrugated metal pipe and pipe arches.
- D. All non-metallic pipe shall meet all requirements as set forth in TDOT Standard Specifications Section 914 and all metallic pipe shall meet all requirements as set forth in TDOT Standard Specifications Section 915.

2.02 CONCRETE PIPE

- A. Concrete pipe culverts shall be Class III concrete.
- B. Non-reinforced concrete pipe shall conform to ASTM C-14 for the specified diameters and strength.
- C. Reinforced concrete pipe shall conform to ASTM C-76 for the specified diameters and strength classes. Horizontal and vertical elliptical pipe shall conform to ASTM C-507. Arch pipe shall conform to ASTM C-506.
- D. Reinforced concrete pipe shall be flat base, round or oval, as shown on the Plans.

2.03 CORRUGATED METAL PIPE (CMP)

- A. All zinc-coated (galvanized) corrugated iron or steel pipe, pipe arches, or underdrains and all special sections (elbows/flared ends) shall be same thickness and shall conform to AASHTO M-36.
- B. Aluminum coated pipe shall conform to AASHTO M-274.
- C. All corrugated aluminum pipe, pipe arches or underdrains and all special sections (elbows/flare ends) shall be same gauge and shall conform to AASHTO M-196.

2.04 PLASTIC AND POLYETHYLENE CORRUGATED TUBING

- A. This tubing/piping shall conform to the requirements of ASTM F-405.
- B. For specified pipe drains (bridge drains), polyethylene pipe shall meet requirements of AASHTO M-294.

- C. Contech A-2000 shall meet the following requirements:
 - 1. Structural backfill shall be placed with 6-inches below the pipe to 6-inches above the pipe.
 - 2. For depths up to 11':
 - a. Sand (A1, A3) compacted to 90% standard proctor.
 - b. Sandy silt (A-2-4, A-2-5) compacted to 90% standard proctor.
 - c. Dumped crushed stone.
 - 3. For depths between 12' and 20':
 - a. Sand (A1, A3) compacted to 95% standard proctor.
 - b. Sandy Silt (A-2-4, A-2-5) compacted to 95% standard proctor.
 - c. Compacted crushed stone.
 - 4. For depths between 21' and 35':
 - a. Sand (A1, A3) compacted to 95% standard proctor.
 - b. Compacted crushed stone.

2.05 CONCRETE MATERIALS

- A. Portland cement concrete shall be Class A concrete, and shall be manufactured, placed and cured in accordance with requirements set for in TDOT Standard Specifications Section 604.

2.06 BRICK

- A. Brick shall conform to AASHTO M-91, and unless otherwise specified or indicated shall be Grade SM and size 8" x 3-5/8" x 2-1/4".

2.07 MASONRY MORTAR

- A. Masonry Mortar shall meet all requirements as set forth by TDOT Standard Specifications Subsection 912.03.

2.08 CASTINGS

- A. Gray Iron castings shall be of the type specified and shall be within close conformity with the dimensions shown on the Plans and meet requirements set forth in TDOT Standard Specifications Subsection 908.07.
- B. The castings shall conform to ASTM A-47 and shall be of Class 30.

2.09 MANHOLES AND CATCHBASINS

- A. Precast manholes and catchbasins shall conform to ASTM C-478.
- B. Section 4.01 of these specifications covers the complete details for manholes and catchbasins.

PART 3 – EXECUTION

3.01 PREPARATION FOR LAYING PIPES

- A. Suitable bedding for laying pipes shall be prepared in accordance with Section 3.08 of these Specifications.

3.02 INSTALLATION OF PIPE CULVERTS AND STORM SEWERS

- A. The installation of pipe culverts and storm sewers shall be conducted in conformance with TDOT Standard Specifications Subsections 607.06 through 607.09 and/or Section 4.02 Subsection 3.01 of these Specifications.

3.03 INSTALLATION OF MANHOLES AND CATCHBASINS

- A. The installation of manholes and catchbasins shall be conducted in conformance with Section 4.01 of these Specifications.
- B. Inverts shall be of Class A concrete and shall conform to the shapes indicated on the Plans and conform uniformly to inlet and outlet pipes.

3.04 INLET AND OUTLET PIPES

- A. Pipes shall extend through the walls of manholes, catchbasins, and inlets for a sufficient distance beyond the outside surface to allow for connections, but shall be cut off flush with the wall on the inside surface.

3.05 CASTINGS AND FITTINGS

- A. All castings and fittings shall be installed in accordance with TDOT Standard Specifications Subsection 611.10.
- B. All castings and fittings shall be placed in the positions indicated on the Plans and shall be set true to line and grade.

3.06 PIPE DRAINS

- A. The constructing and placing of pipe drains shall be accordance with TDOT Standard Specifications Subsections 610.04 through 610.10.

3.07 UNDERDRAINS

- A. The constructing and placing of underdrains shall be accordance with TDOT Standard Specifications Subsections 710.05 through 710.08.

END OF SECTION

SECTION 7.02

RIP-RAP

PART 1 – GENERAL

1.01 WORK INCLUDED

- A. This shall consist of furnishing and placing rubble stones, crushed stones, or sacked sand cement within reasonably close conformity to the lines, grades, and cross sections and at the location indicated on the Plans.
- B. The construction shall be completed in accordance with these Specifications and TDOT Standard Specifications Section 709.

1.02 RELATED WORK

- A. Section 3.01: Clearing
- B. Section 3.04: Finish Grading

1.03 APPLICABLE SPECIFICATIONS

“Standard Specifications for Road and Bridge Construction”, Latest Revision, Tennessee Department of Transportation (TDOT).

1.04 APPLICABLE REFERENCES

“American Association of State Highway and Transportation Officials” (AASHTO).

“American Society for Testing and Materials” (ASTM).

PART 2 – PRODUCTS

2.01 GENERAL INFORMATION

- A. When rock or stone is used as riprap, the material when subjected to five alternations of the sodium sulfate soundness test (AASHTO T-104), shall not have a weighted percentage of loss of more than 12.

2.02 RUBBLE-STONE RIP-RAP

- A. Rubble-stone rip-rap shall consist of stone, broken Class “A” or paving concrete that shall be sound, dense and durable, free from excessive cracks, pyrite intrusions and other structural defects.

- B. The material shall be rectangular and/or trapezoidal in shape with 80% having a minimum dimension of 10 inches and the other 20 % ranging from 2 to 4 inches.

2.03 SACKED SAND CEMENT

- A. Sacks shall be made of either cotton or jute, standard grade of cloth, which will hold mixture without leakage.
- B. Sacks shall hold approximately one cubic foot.
- C. The sand and cement shall meet the requirements set forth by TDOT Standard Specifications Subsections 901.01, 903.01 and/ or 903.02.

2.04 MACHINED RIP-RAP

- A. Machined rip-rap shall be clean shot rock and shall be uniformly distributed throughout the size range.
- B. Machined rip-rap shall be classified as Class A-1, A-2, A-3, B or C, as described in TDOT Standard Specifications Subsection 709.03.

PART 3 – EXECUTION

3.01 PREPARATION

- A. Immediately prior to the placing of rip-rap, trim surfaces in reasonably close conformity to the lines and grades indicated on Plans.
- B. On slopes, prepare surface to place the bottom of the rip-rap at least 2 feet below the natural ground surface.

3.02 RUBBLE-STONE RIP-RAP

- A. The construction and placing of rubble-stone rip-rap shall be in accordance with TDOT Standard Specifications Subsection 709.06.
- B. Stone shall be hand placed upon the prepared foundation, so that the stones are as close together as in practicable to reduce voids.
- C. The standard depth of the rubble-stone rip-rap shall be 12 inches, unless otherwise indicated on the Plans.

3.03 SACKED-SAND CEMENT RIP-RAP

- A. The construction and placing of sacked sand-cement rip-rap shall be in accordance with TDOT Standard Specifications Subsection 709.07.

- B. Sacks shall be filled approximately $\frac{3}{4}$ full with a mixture of sand and cement on the prepared foundation.
- C. Sacks shall be placed in a manner as to reduce voids.

3.04 CONCRETE BLOCK RIP-RAP

- A. The construction and placing of concrete block rip-rap shall be in accordance with TDOT Standard Specifications Subsection 604.08.
- B. The concrete blocks shall be placed by hand upon the prepared foundation with each block against the adjoining blocks with sides and ends in contact.
- C. The blocks shall be placed in a manner that the joints will be staggered.

END OF SECTION

SECTION 8.01

UNDERGROUND ELECTRICAL

For electric service within the Town of Chapel Hill service boundary contact Duck River Electric Membership Corporation.

END OF SECTION

NOTES:

1. DO NOT USE GRADE RINGS WHERE MH EXTENDS ABOVE GRADE.
2. PLACE 2 STRIPS OF BUTYL RUBBER SEALANT BETWEEN TOP OF CONCRETE AND BOTTOM OF MANHOLE FRAME. GROUT FRAME AND COVER TO MANHOLE.
3. ALL PRECAST MANHOLE SEGMENTS TO MEET REQUIREMENTS OF ASTM C478
4. WHERE GRADE ADJUSTMENT IS DONE, A MANHOLE FRAME SEAL SHALL BE PROVIDED.
5. MANHOLE 4.1' TO 12' TO BE 48" DIAMETER. MANHOLE 12.1' TO 18' TO BE 60" DIAMETER.

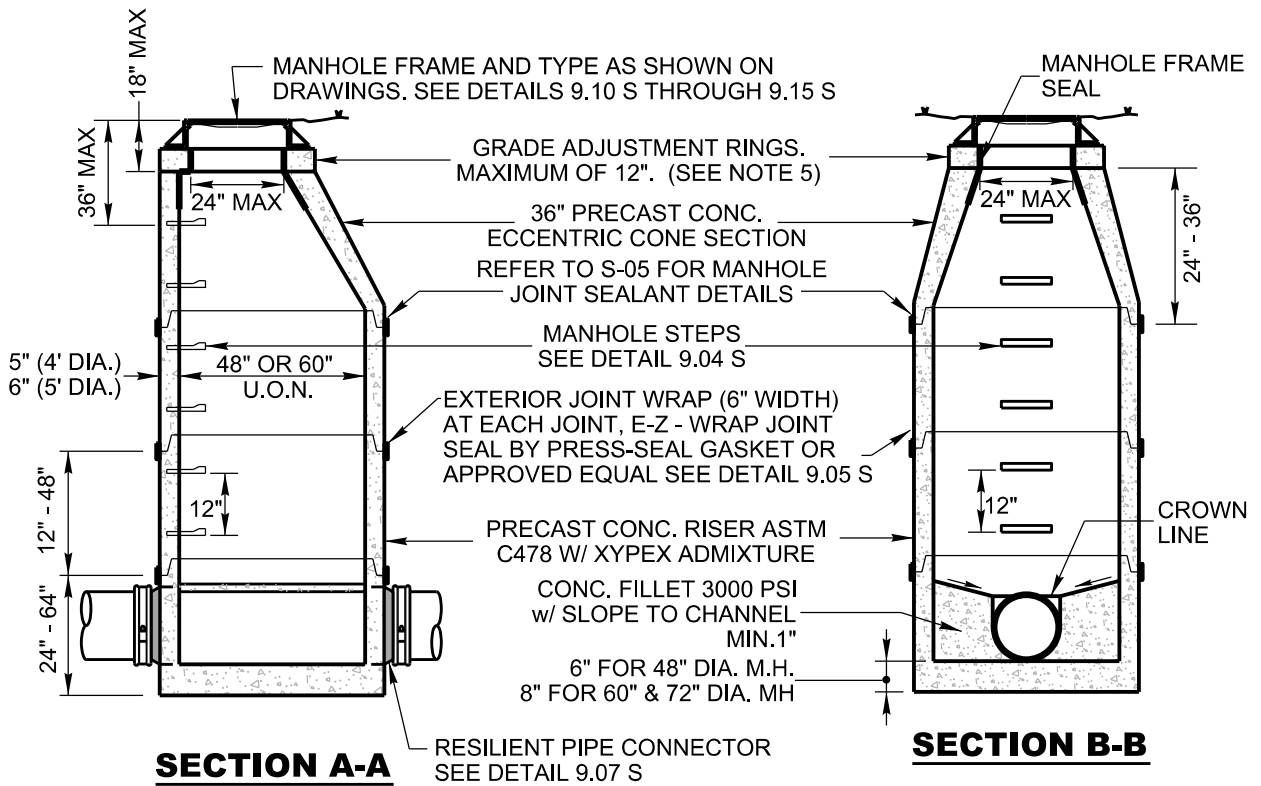
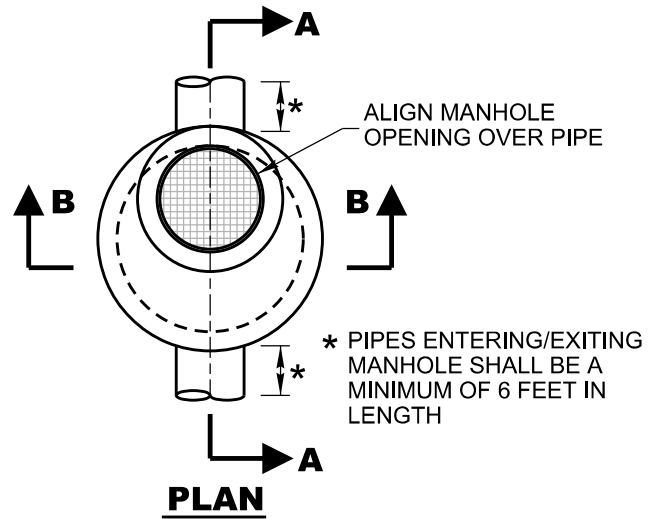

DATE: 07/2022

NOT TO SCALE

TYPICAL SANITARY SEWER MANHOLE

STANDARD DETAIL

TOWN OF CHAPEL HILL
CHAPEL HILL, TENNESSEE

MANHOLE FRAME AND TYPE AS SHOWN ON DRAWINGS. SEE DETAIL 9.10 S THOUGH 9.15 S

DO NOT USE GRADE RINGS WHERE MH EXTENDS ABOVE GRADE

GRADE ADJUSTMENT RING, MAXIMUM OF 12"

PAVEMENT

VARIES (AS REQUIRED) SEE NOTE 3

28" OR 36"

12" - 48"

78" MIN.

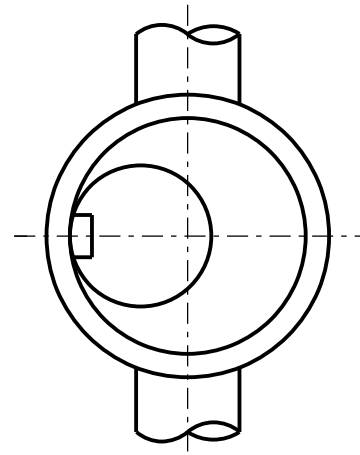
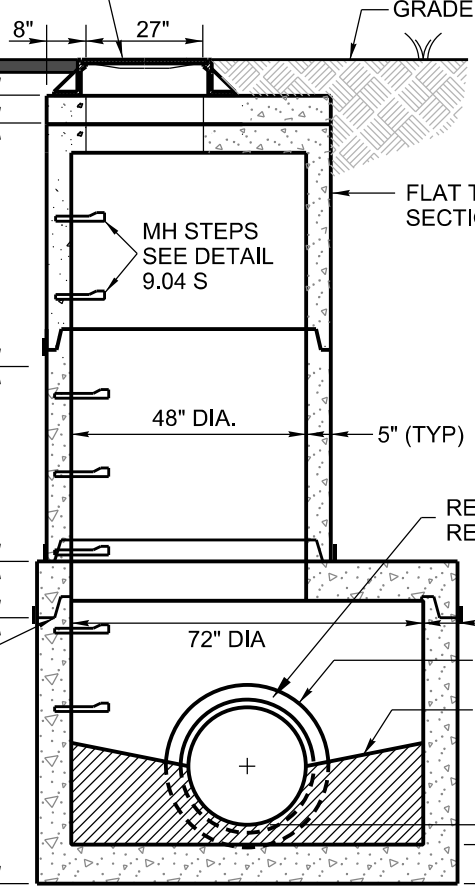

PLAN

FLAT TOP PRECAST SECTION

MH STEPS SEE DETAIL 9.04 S

48" DIA.

5" (TYP)

RESILIENT PIPE CONNECTOR. REFER TO DETAIL 9.07 S

72" DIA

7" (TYP)

OPENINGS FOR PIPE CAST AS REQUIRED

CONCRETE INVERT AS REQUIRED

REFER TO DETAIL 9.05 S FOR JOINT SEALANT

NOTES:

- 1) REINFORCING EQUAL TO ASTM-C478 SPECIFICATIONS
- 2) CONCRETE TO HAVE XYPEX ADMIXTURE
- 3) USE FOR MANHOLES 18.1' AND DEEPER

DATE: 07/2022

NOT TO SCALE

72" TO 48" TRANSITION MANHOLE

STANDARD DETAIL

TOWN OF CHAPEL HILL
CHAPEL HILL, TENNESSEE

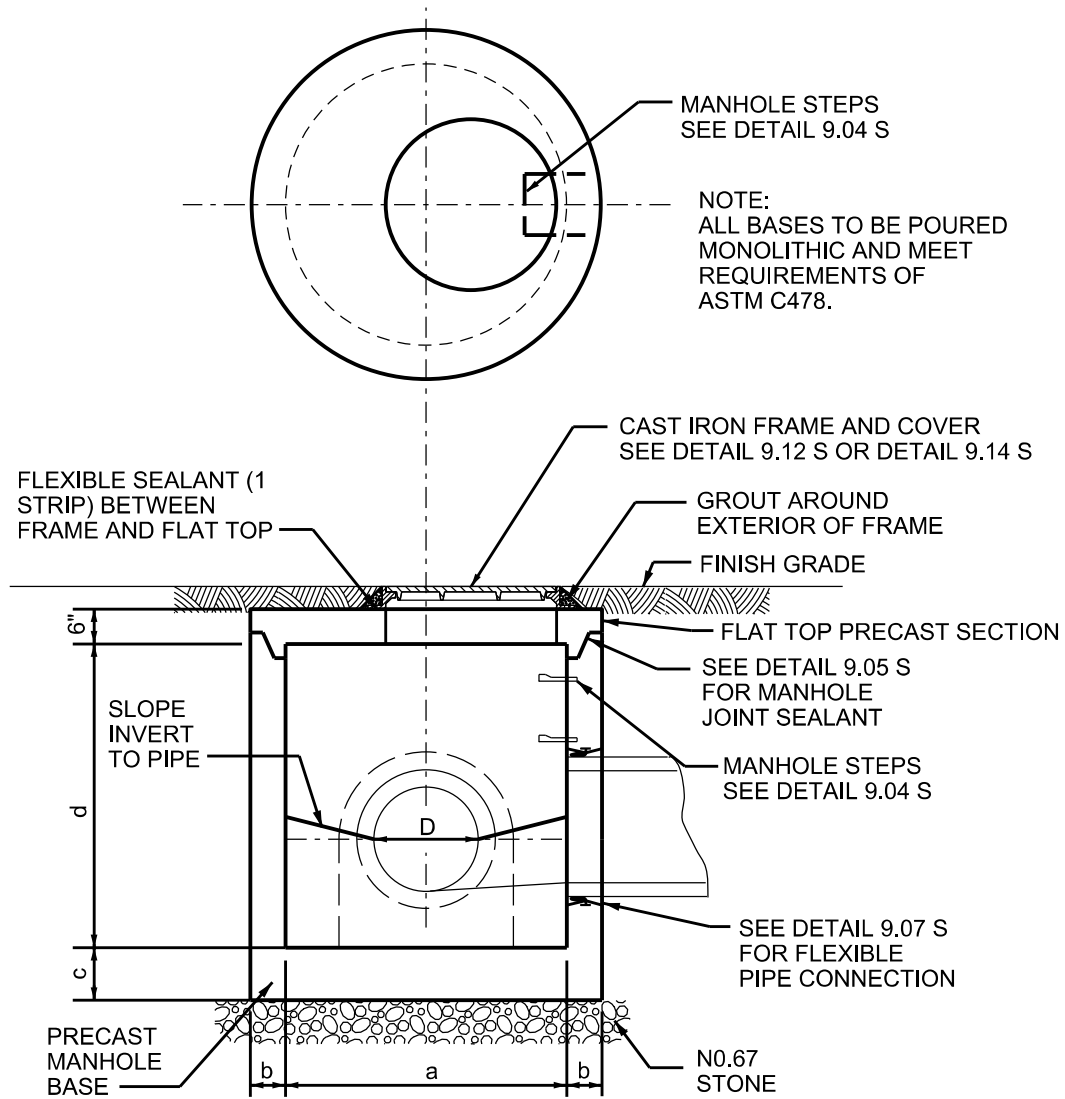

PIPE DIAMATER	MANHOLE DIAMATER	WALL THICKNESS	BASE THICKNESS	MIN. RISER HEIGHT	MAX. RISER HEIGHT
D	a	b	c	d	d
< 16"	4'-0"	5"	8"	2'-6"	5'-8"

DATE: 07/2022

NOT TO SCALE

SHALLOW TYPE MANHOLE

STANDARD DETAIL

TOWN OF CHAPEL HILL
CHAPEL HILL, TENNESSEE

9.03 S

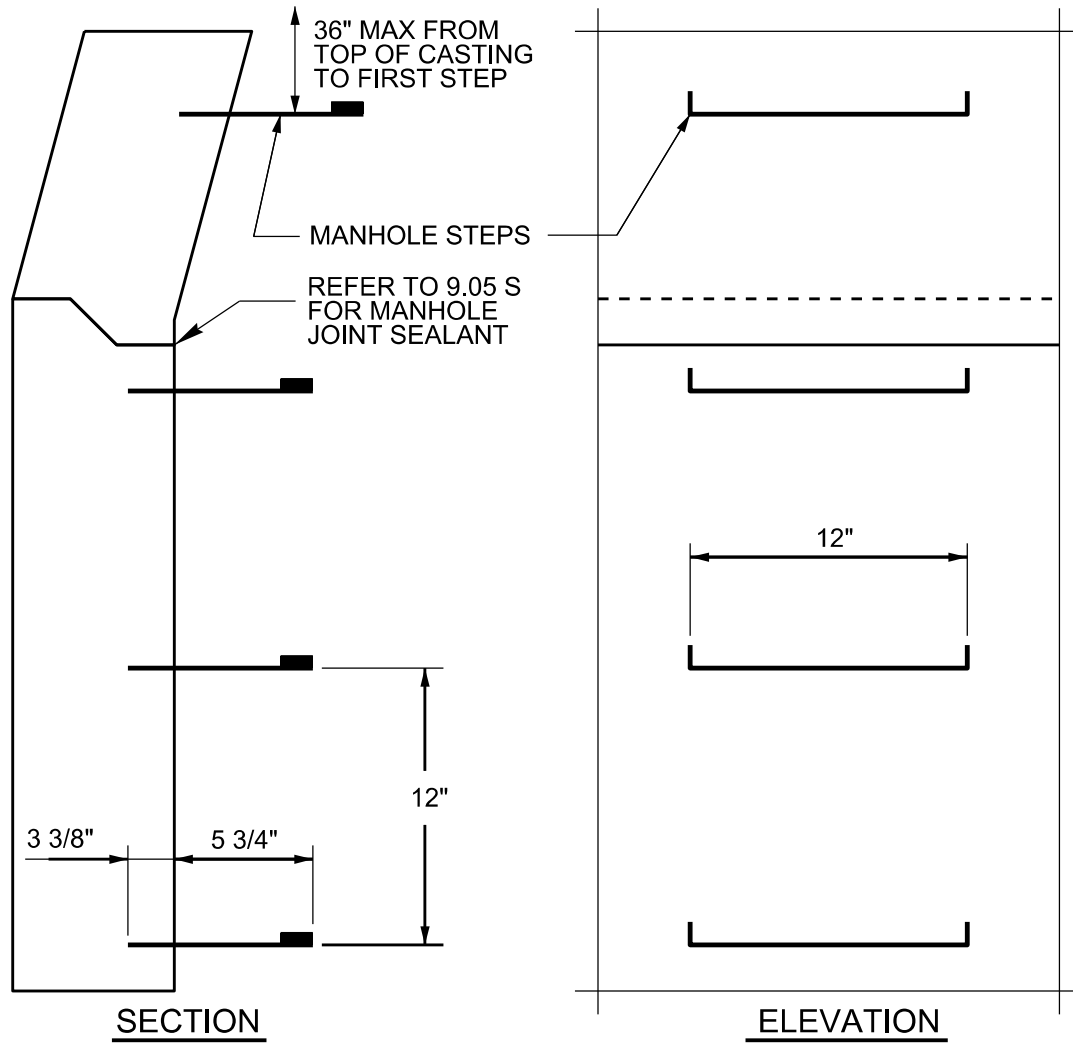

1. STEPS TO BE INTEGRALLY CAST INTO MANHOLE SECTION.
2. STEPS TO BE ALIGNED VERTICALLY THROUGHOUT EACH MANHOLE SECTION
3. LAST STEP TO BE 12" ABOVE PIPE
4. STEPS TO BE 3/4" FORMED ALUMINUM RUNGS OR STEEL - REINFORCED, COPOLYMER POLYPROPYLENE PLASTIC COVERED.

DATE: 07/2022

NOT TO SCALE

TYPICAL MANHOLE STEPS

STANDARD DETAIL

TOWN OF CHAPEL HILL
CHAPEL HILL, TENNESSEE

9.04 S

NOTE:
 WHERE MASTIC DOES NOT PROTRUDE, EITHER
 INSIDE OR OUTSIDE, POINT UP JOINT WITH
 GROUT

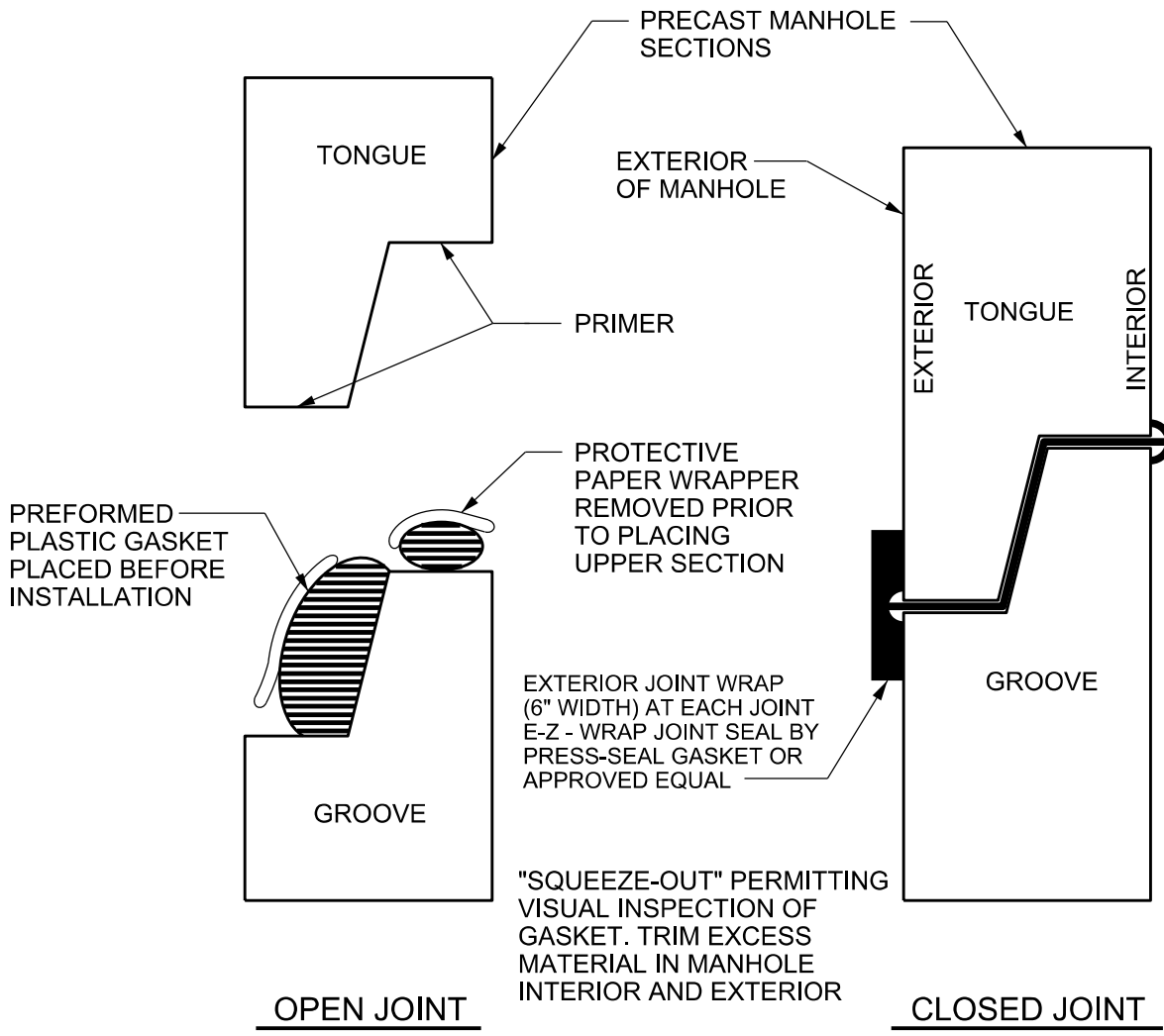

DATE: 07/2022

NOT TO SCALE

MANHOLE JOINT SEALANT

STANDARD DETAIL

TOWN OF CHAPEL HILL
 CHAPEL HILL, TENNESSEE

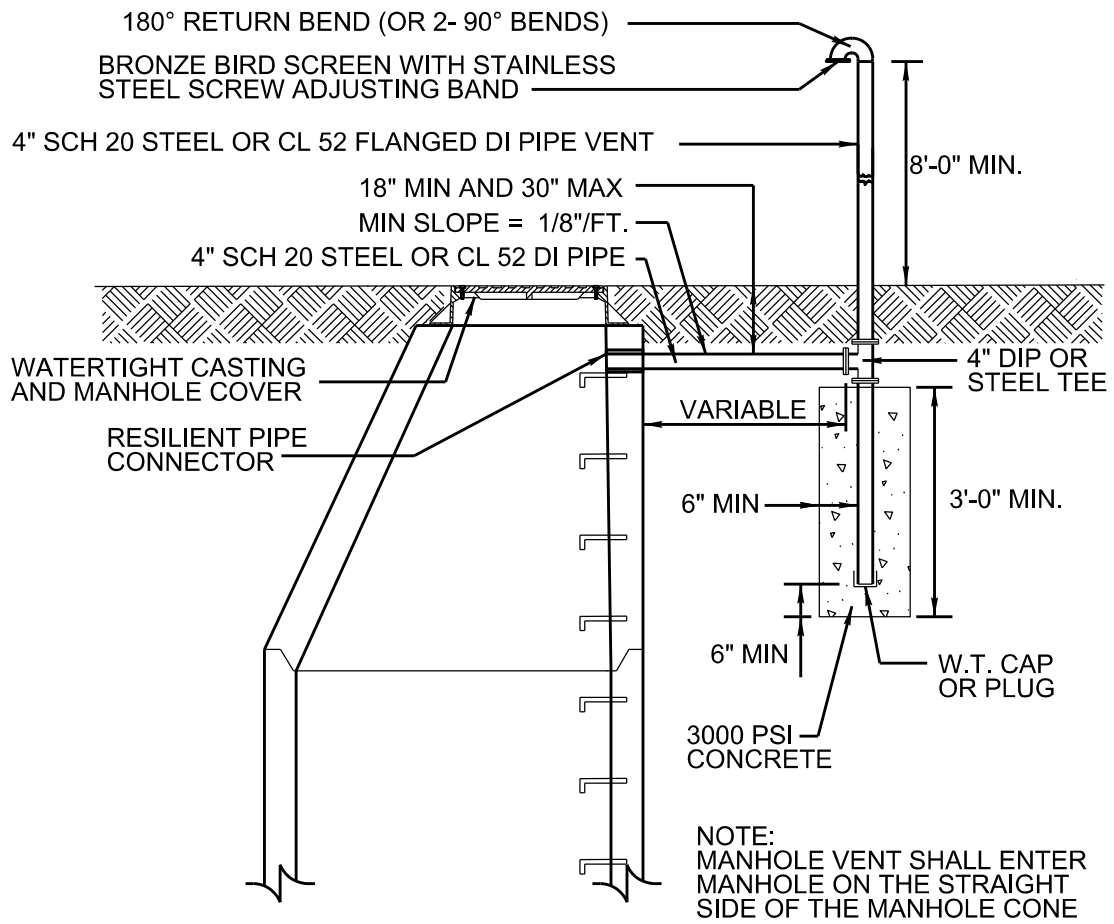

NOTES:

1. PIPE EXTERIOR TO BE PAINTED WITH ONE COAT OF PRIMER, AND TWO COATS OF DARK GREEN ENAMEL.
2. PIPE INTERIOR TO BE LINED WITH TNEMEC SERIES 10 PRIMER, PROTECTO 401, OR EQUAL. (SSPC-SP3 SURFACE PREPARATION).
3. TOP OF VENT TO BE MINIMUM OF 8'-0" ABOVE GRADE OR 1' ABOVE 100 YEAR FLOOD ELEVATION.

DATE: 07/2022

NOT TO SCALE

MANHOLE VENT ASSEMBLY

STANDARD DETAIL

TOWN OF CHAPEL HILL
CHAPEL HILL, TENNESSEE

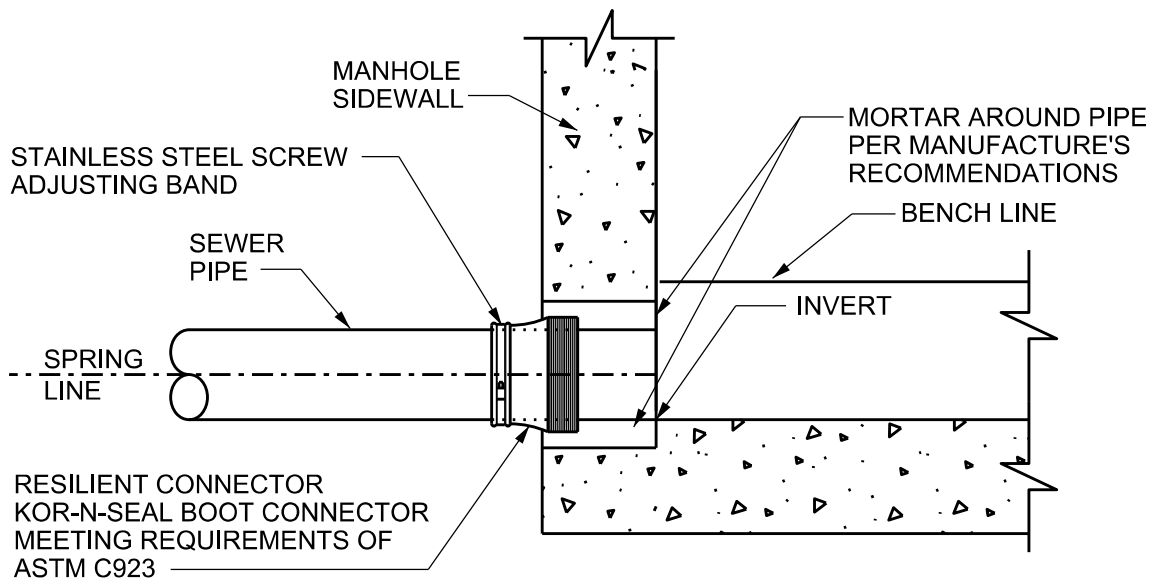

NOTE:

1. PIPES ENTERING/EXITING MANHOLES SHALL BE A MINIMUM OF 6 FT IN LENGTH

DATE: 07/2022

NOT TO SCALE

FLEXIBLE MANHOLE PIPE CONNECTION

STANDARD DETAIL

TOWN OF CHAPEL HILL
CHAPEL HILL, TENNESSEE

9.07 S

DROP SIZE NOTE:

FOR GRAVITY SEWERS, DROP SIZES SHALL BE 8" FOR MAIN LINE UP THROUGH 12";
10" FOR MAIN LINE 15" AND LARGER.

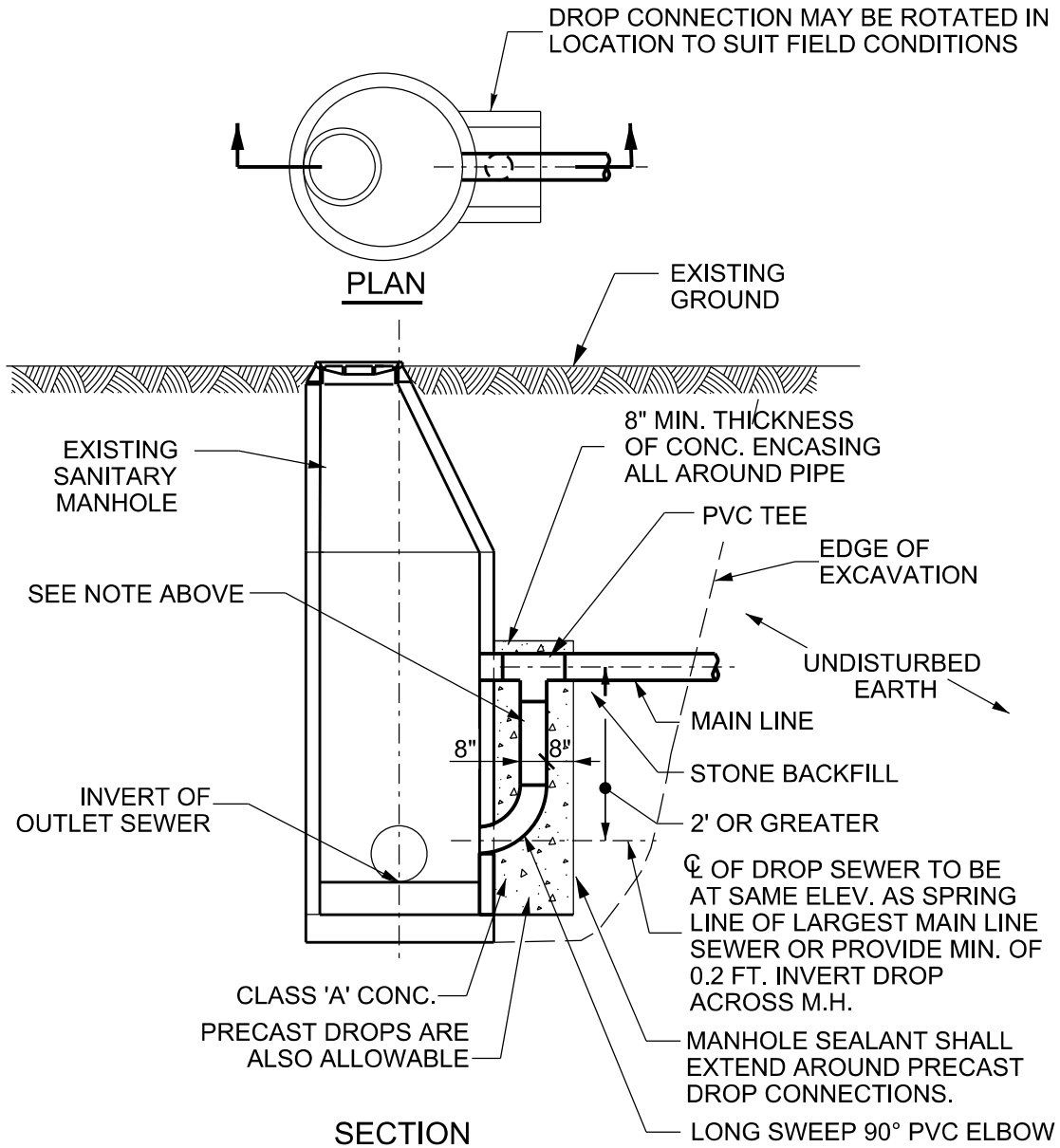

DATE: 07/2022

NOT TO SCALE

**EXTERIOR DROP MANHOLE CONNECTION
(GRAVITY LINE ONLY)**

STANDARD DETAIL

TOWN OF CHAPEL HILL
CHAPEL HILL, TENNESSEE

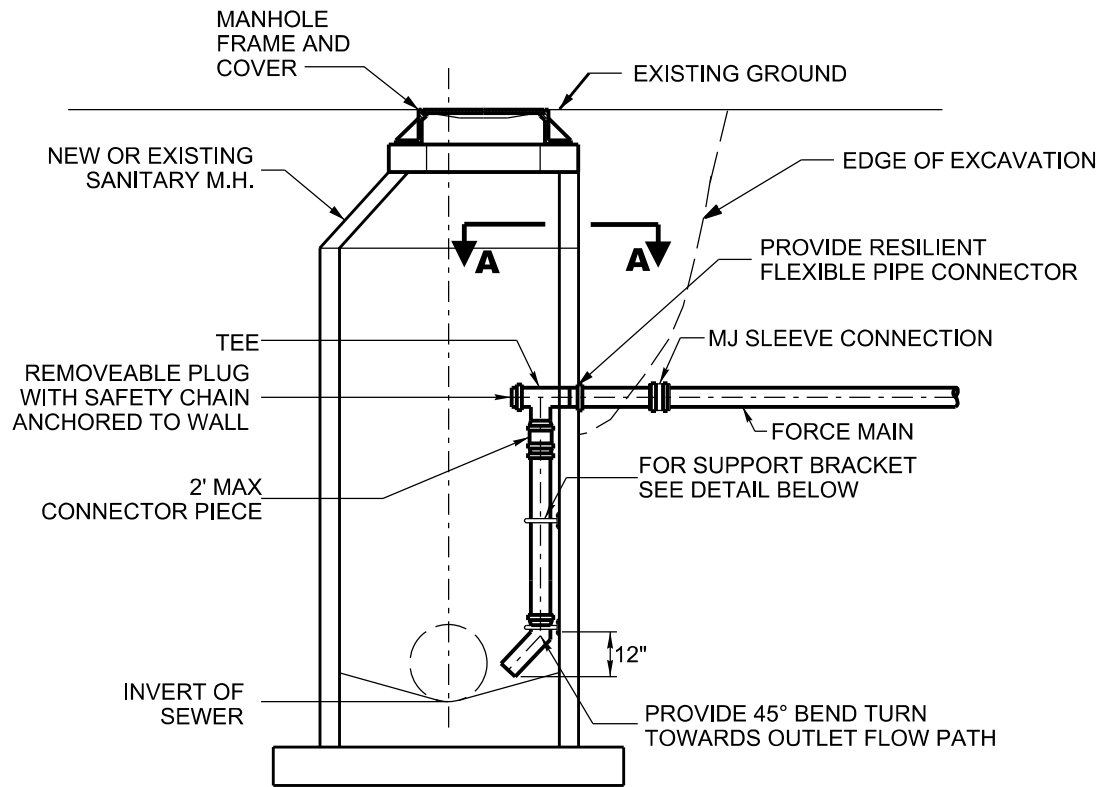

SECTION

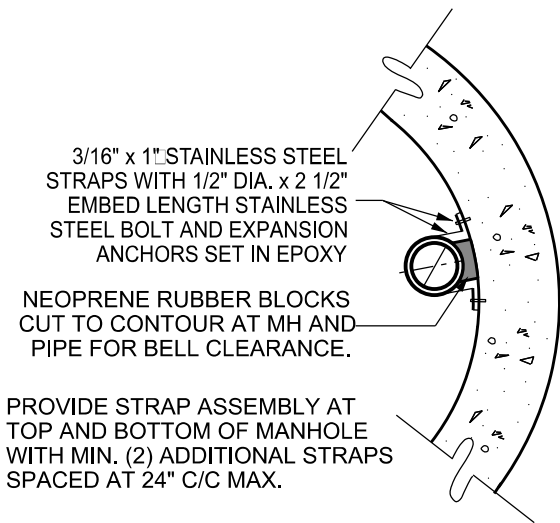

SECTION A-A

NOTES:

1. LEVEL "GREEN" MANHOLE LINING SHALL BE APPLIED TO EXISTING MANHOLE, PLUS TWO IMMEDIATE DOWNSTREAM MANHOLES.
2. LEVEL "BLUE" MANHOLE LINING SHALL BE APPLIED TO NEW MANHOLE, PLUS TWO IMMEDIATE DOWNSTREAM MANHOLES.
3. INTERIOR PIPING TO BE SAME SIZE AS FORCE MAIN PIPING, AND SHALL BE SCHEDULE 40 w/ GLUED JOINTS.

DATE: 07/2022

NOT TO SCALE

**INTERIOR DROP MANHOLE CONNECTION
(FORCE MAIN CONNECTION ONLY)**

STANDARD DETAIL

TOWN OF CHAPEL HILL
CHAPEL HILL, TENNESSEE

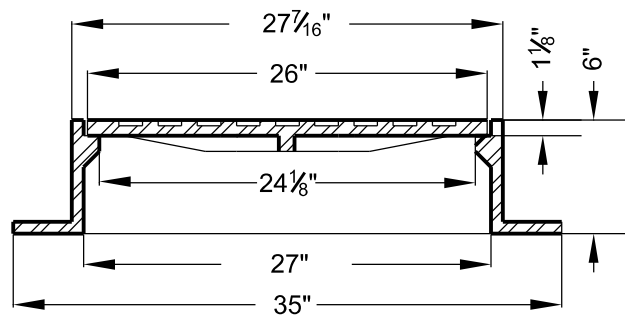
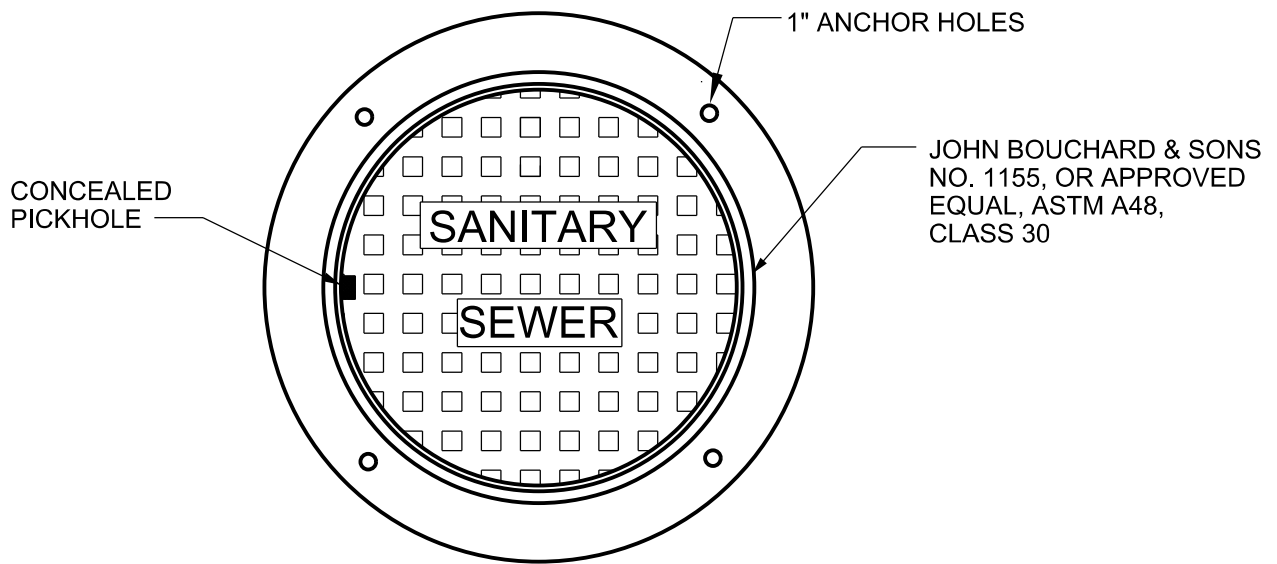

DATE: 07/2022

NOT TO SCALE

NON-TRAFFIC TYPE MANHOLE FRAME AND COVER

STANDARD DETAIL

TOWN OF CHAPEL HILL
CHAPEL HILL, TENNESSEE

9.10 S

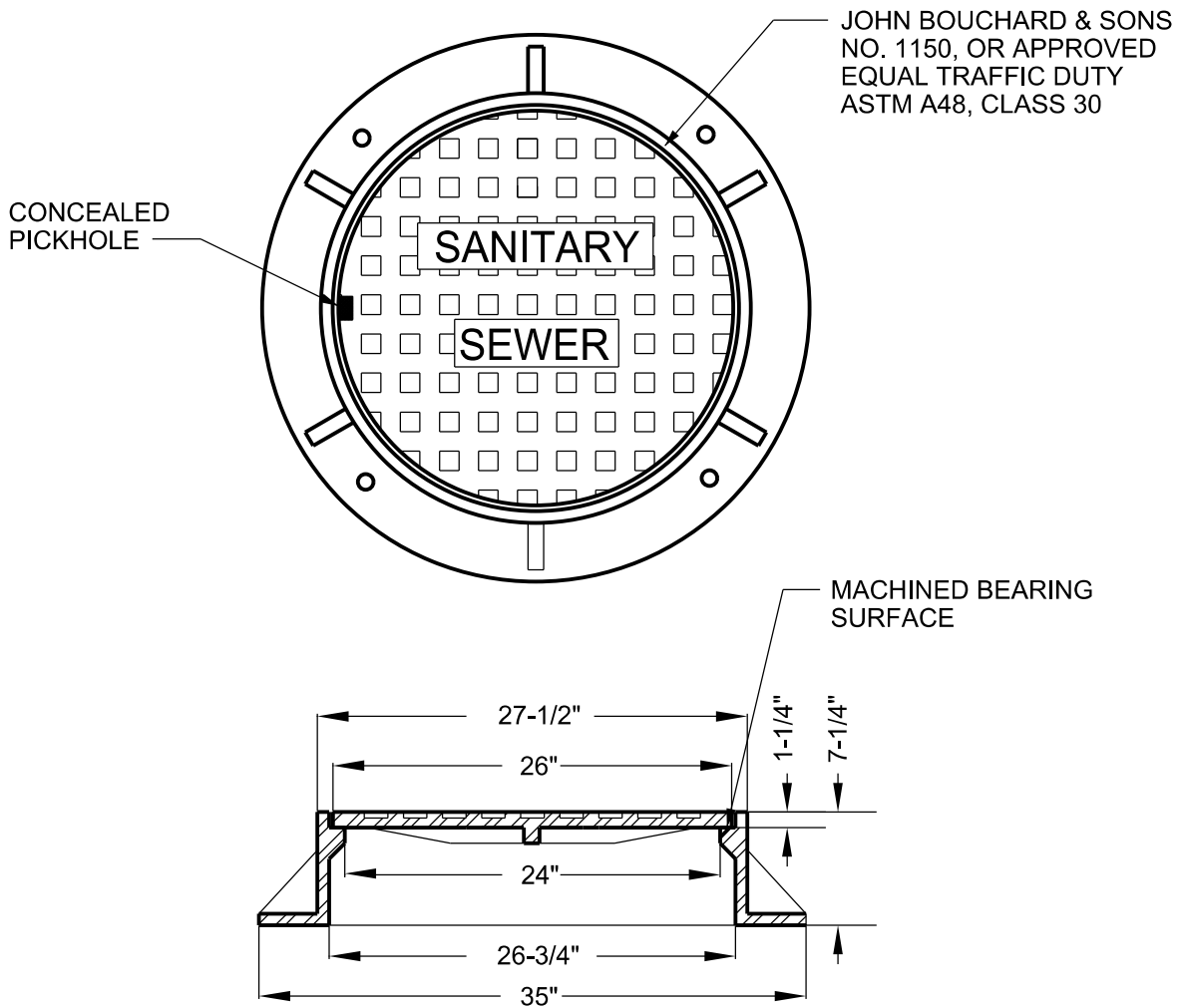

DATE: 07/2022

NOT TO SCALE

TRAFFIC TYPE MANHOLE FRAME AND COVER

STANDARD DETAIL

TOWN OF CHAPEL HILL
CHAPEL HILL, TENNESSEE



JOHN BOUCHARD & SONS
 NO. 1312, OR APPROVED
 EQUAL ASTM A48, GRADE 30

CONCEALED PICK HOLE

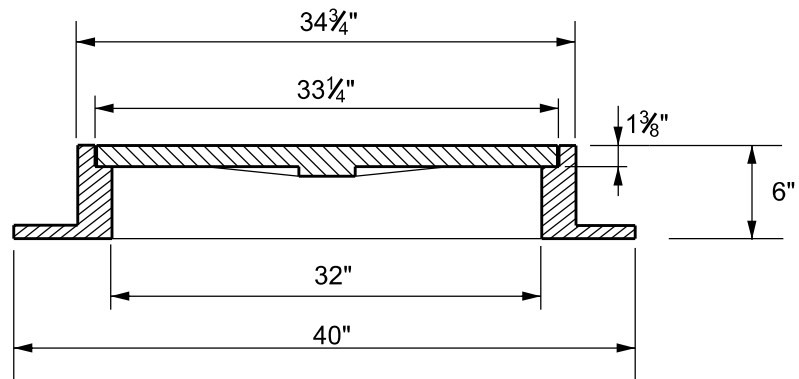

DATE: 07/2022

NOT TO SCALE

SHALLOW TYPE MANHOLE FRAME AND COVER

STANDARD DETAIL

TOWN OF CHAPEL HILL
 CHAPEL HILL, TENNESSEE

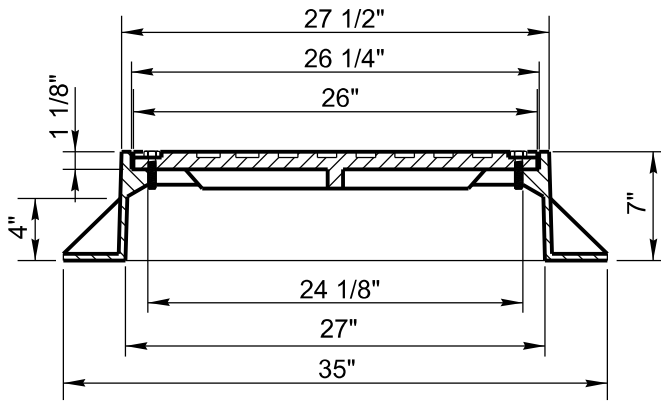
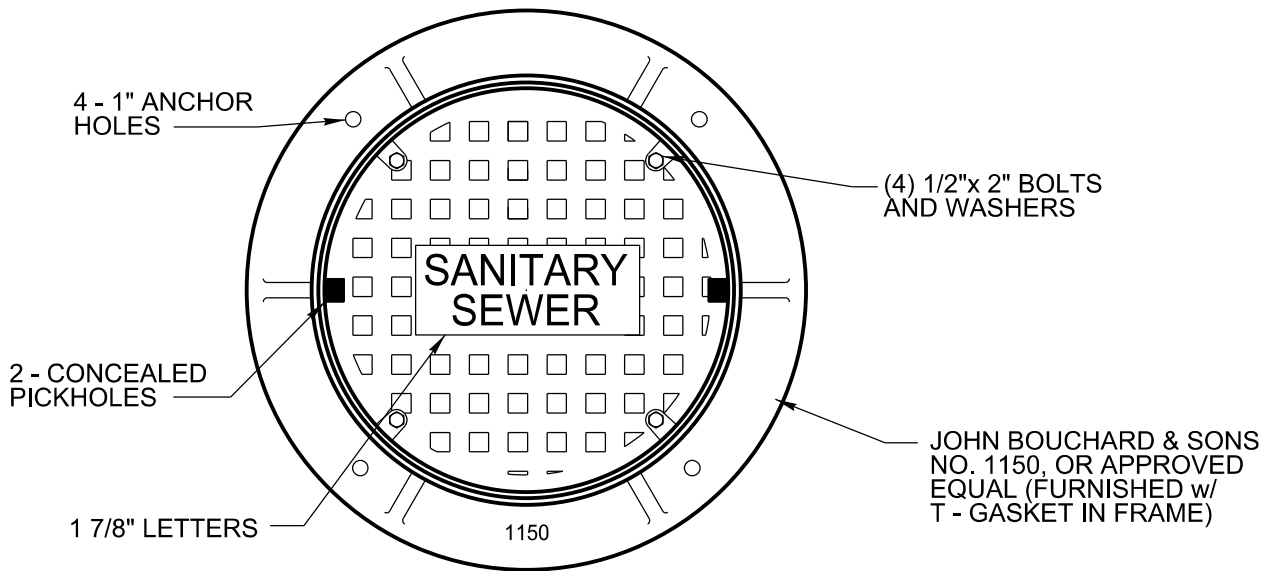

- NOTES:
 1. MACHINED BEARING SURFACES
 2. HEAVY DUTY, H20 LOAD RATED

DATE: 07/2022

NOT TO SCALE

WATERTIGHT MANHOLE FRAME AND COVER

STANDARD DETAIL

TOWN OF CHAPEL HILL
 CHAPEL HILL, TENNESSEE

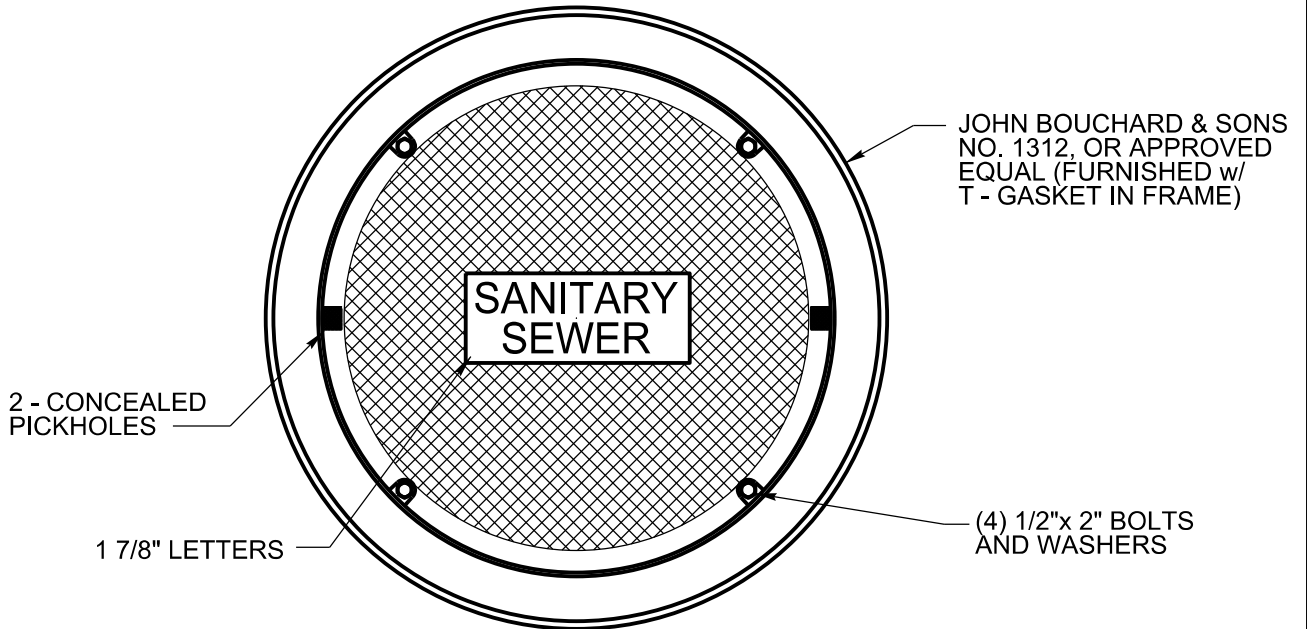

- NOTES:
 1. MACHINED BEARING SURFACES
 2. TRAFFIC DUTY

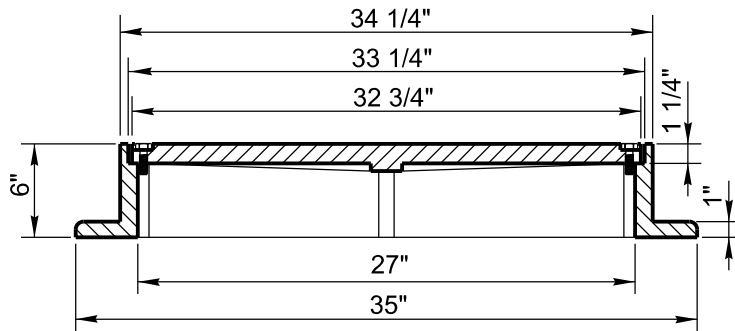

DATE: 07/2022

NOT TO SCALE

SHALLOW TYPE MANHOLE WATERTIGHT FRAME AND COVER

STANDARD DETAIL

TOWN OF CHAPEL HILL
 CHAPEL HILL, TENNESSEE

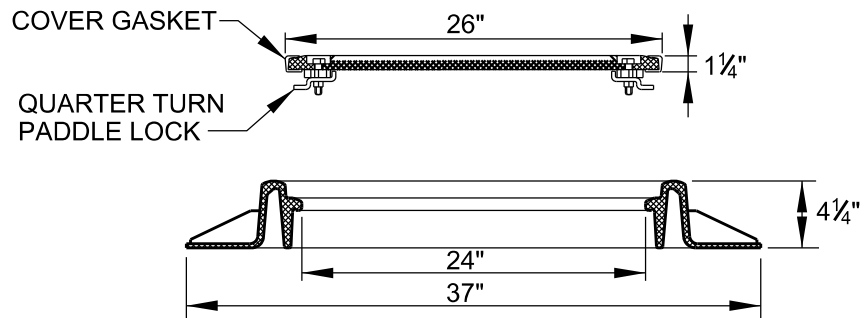
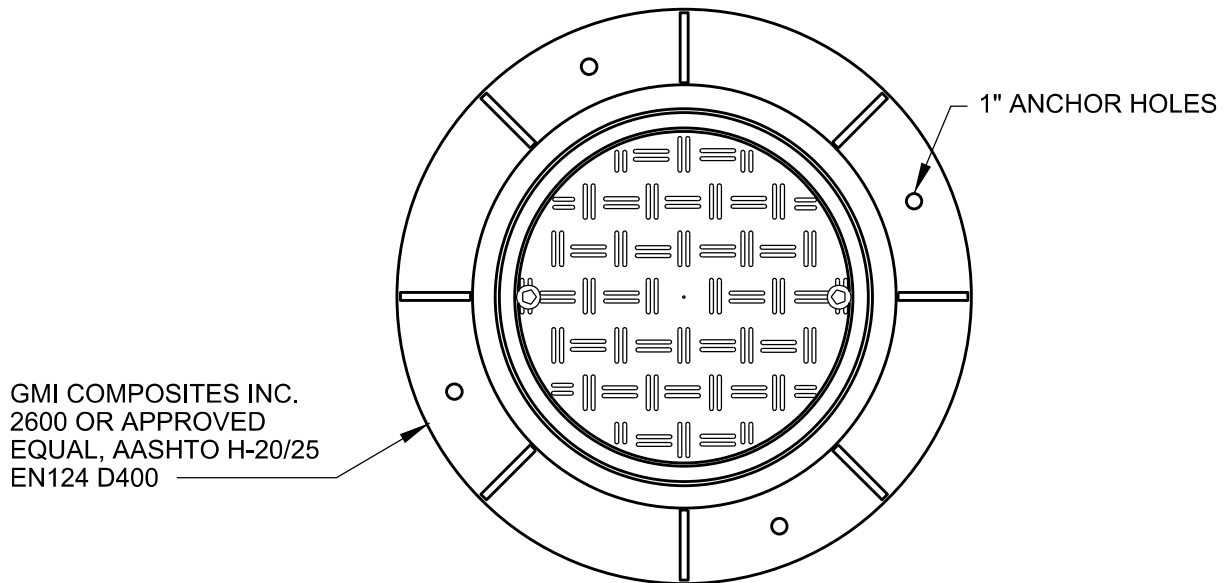

NOTE:
 THIS STYLE MANHOLE FRAME AND COVER TO
 BE USED ON MANHOLES WHERE FORCE MAINS
 CONNECT OR AS DIRECTED BY THE TOWN
 OF CHAPEL HILL.

DATE: 07/2022

NOT TO SCALE

COMPOSITE MANHOLE FRAME AND COVER

STANDARD DETAIL

TOWN OF CHAPEL HILL
 CHAPEL HILL, TENNESSEE

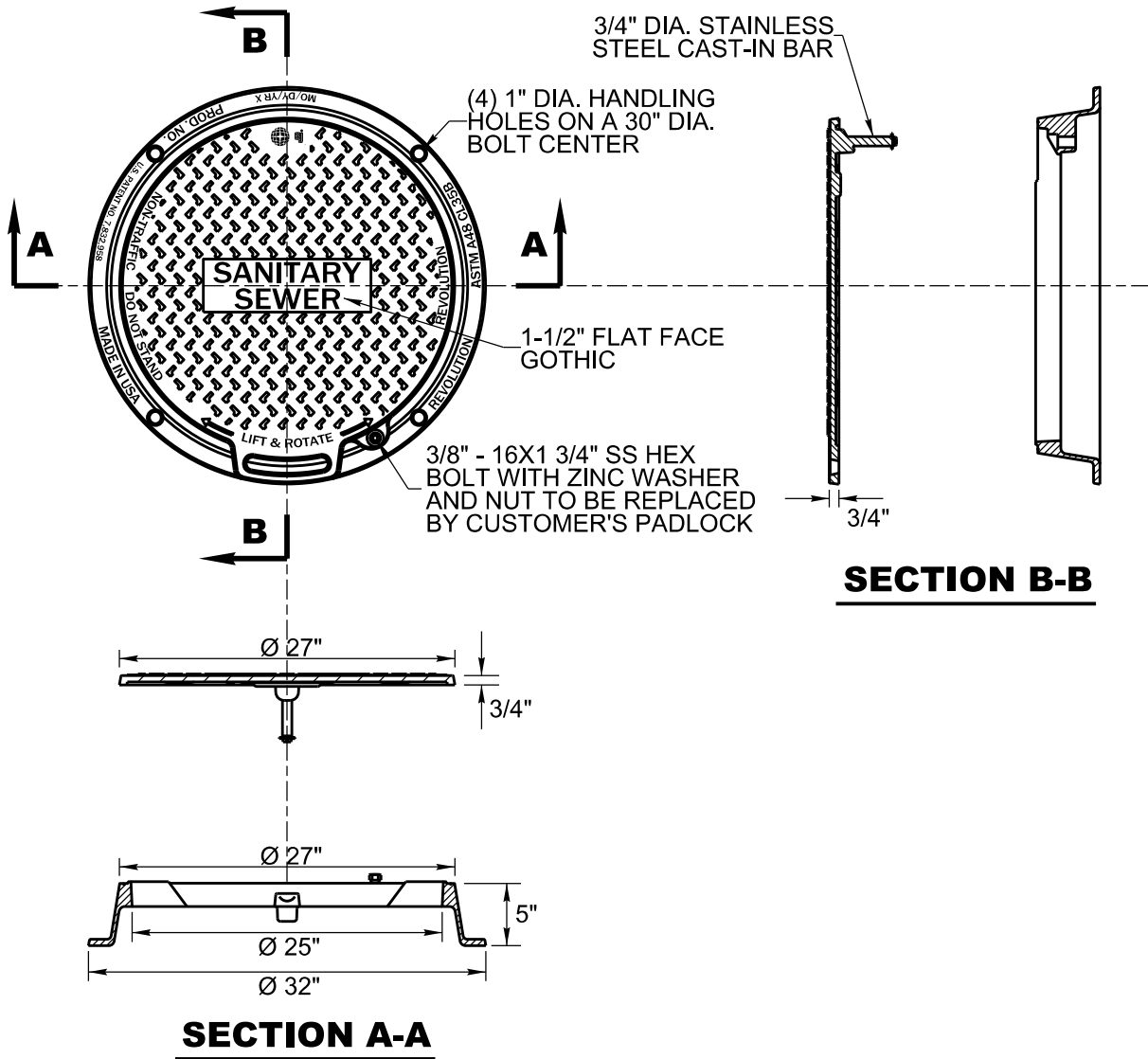

DATE: 07/2022

NOT TO SCALE

MANHOLE FRAME AND COVER

STANDARD DETAIL

TOWN OF CHAPEL HILL
CHAPEL HILL, TENNESSEE

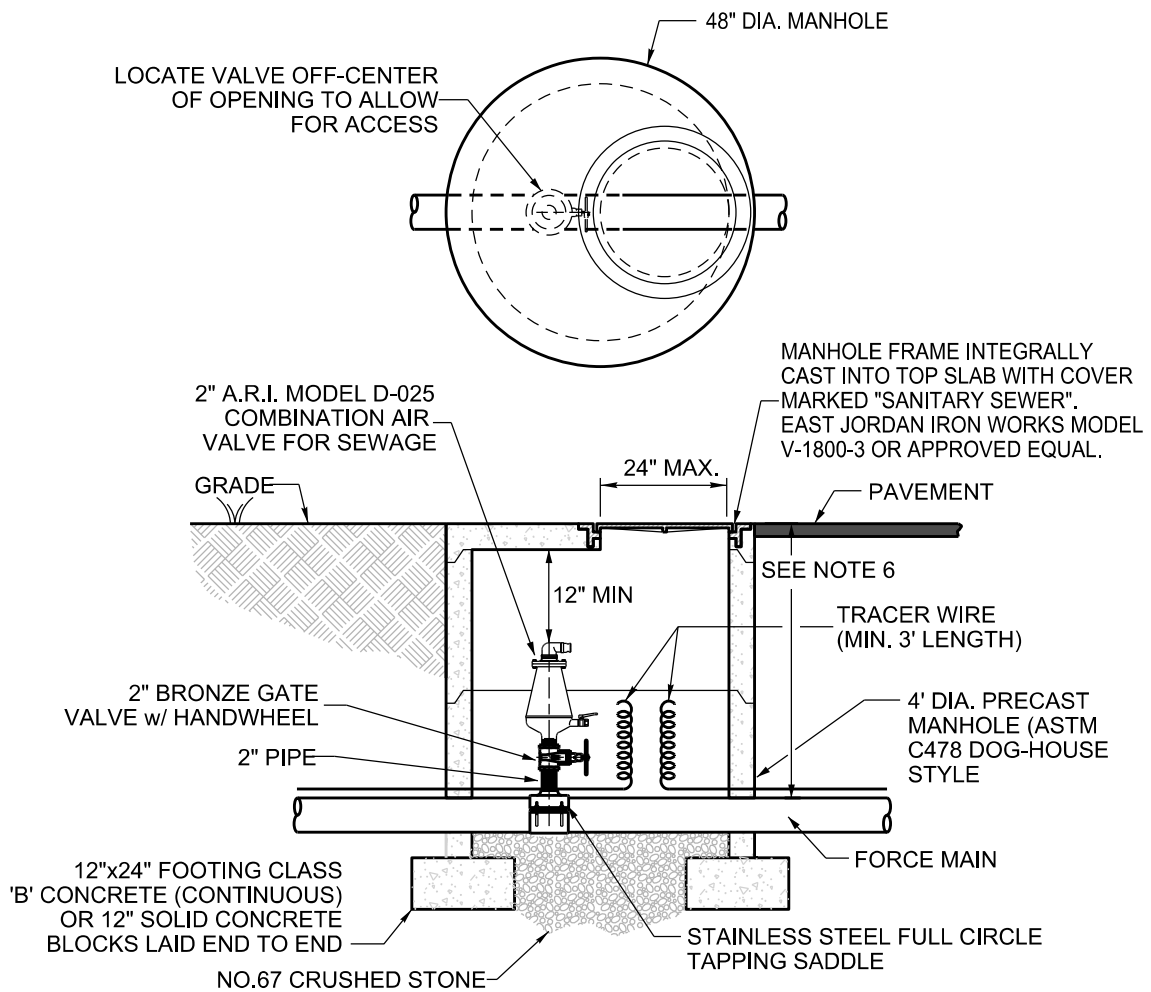

NOTES:

1. COMBINATION AIR VALVE TO BE INSTALLED AT ACTUAL HIGH POINT OF LINE. CONTRACTOR SHALL COORDINATE LOCATION WITH INSPECTOR
2. ALL PIPING FOR COMBINATION AIR VALVE SHALL BE STAINLESS STEEL.
3. CONTRACTOR SHALL ADJUST THE DEPTH OF THE FORCE MAIN AT ALL HIGH POINTS TO ACCOMMODATE THE INSTALLATION OF THE COMBINATION AIR VALVE.
4. TERMINATE TRACER WIRE INSIDE VALVE VAULT.
5. APPLY NON-SHRINK GROUT AS NEEDED AT PIPE-TO-MANHOLE CONNECTION TO PREVENT SEDIMENTATION INSIDE MANHOLE.
6. DEPTH OF ARV MANHOLE SHALL BE OF SUFFICIENT DEPTH SO THAT FLAT-TOP SECTION AND CASTING ARE FLUSH WITH GRADE. CONTRACTOR SHALL MODIFY PIPE DEPTH AS NEEDED DURING INSTALLATION TO ACCOMMODATE DEPTH OF STRUCTURE.

DATE: 07/2022

NOT TO SCALE

TYPICAL SEWAGE COMBINATION AIR VALVE ASSEMBLY

STANDARD DETAIL

TOWN OF CHAPEL HILL
CHAPEL HILL, TENNESSEE

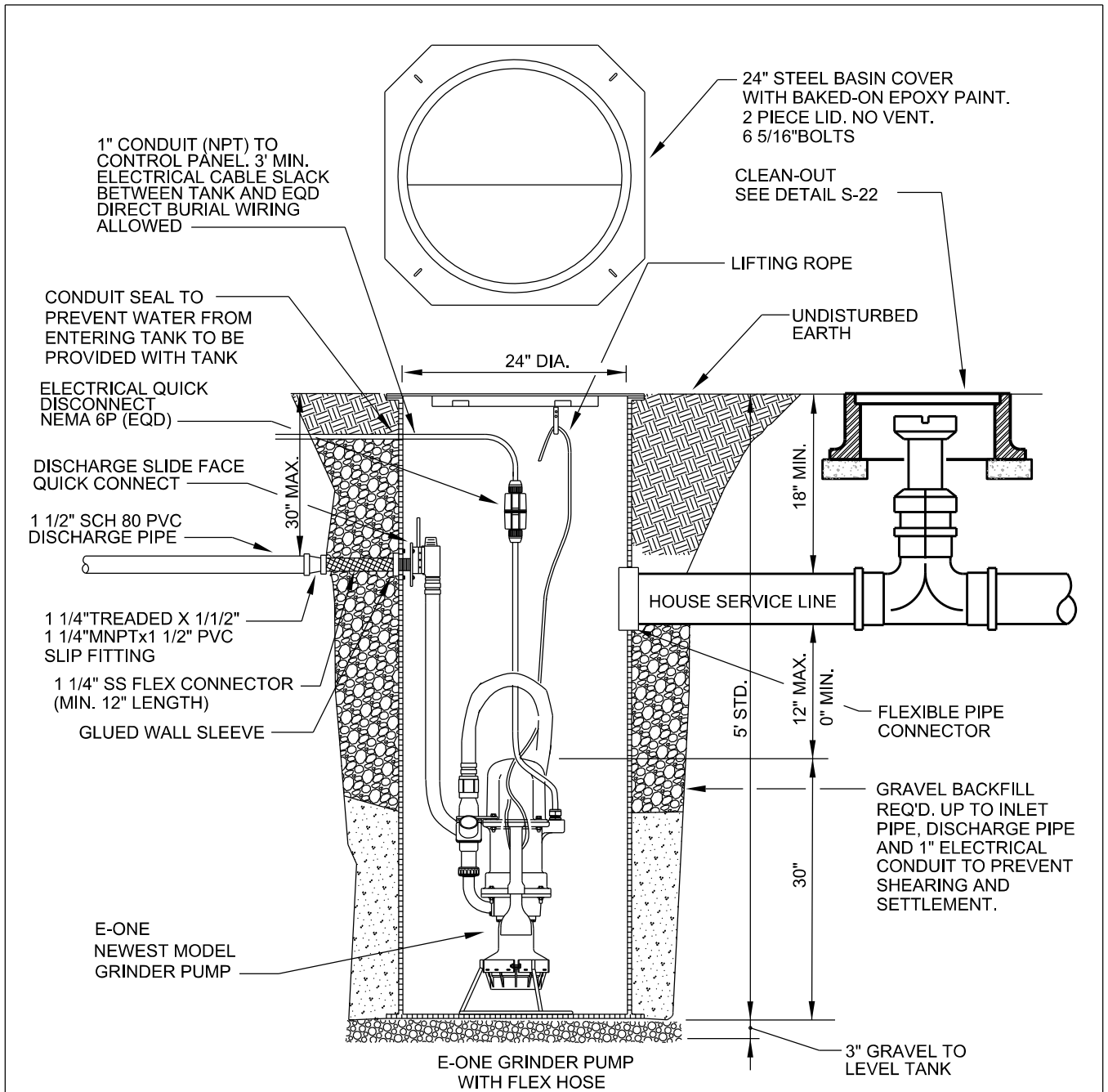

CONCRETE POURED AROUND BASIN TO PREVENT FLOTATION SHALL BE AS RECOMMENDED BY THE GRINDER PUMP MANUFACTURER. 2 CUBIC FEET OF CONCRETE REQUIRED PER FOOT OF BASIN DEPTH MINIMUM.

DATE: 07/2022

NOT TO SCALE

TYPICAL GRINDER PUMP

STANDARD DETAIL

TOWN OF CHAPEL HILL
CHAPEL HILL, TENNESSEE

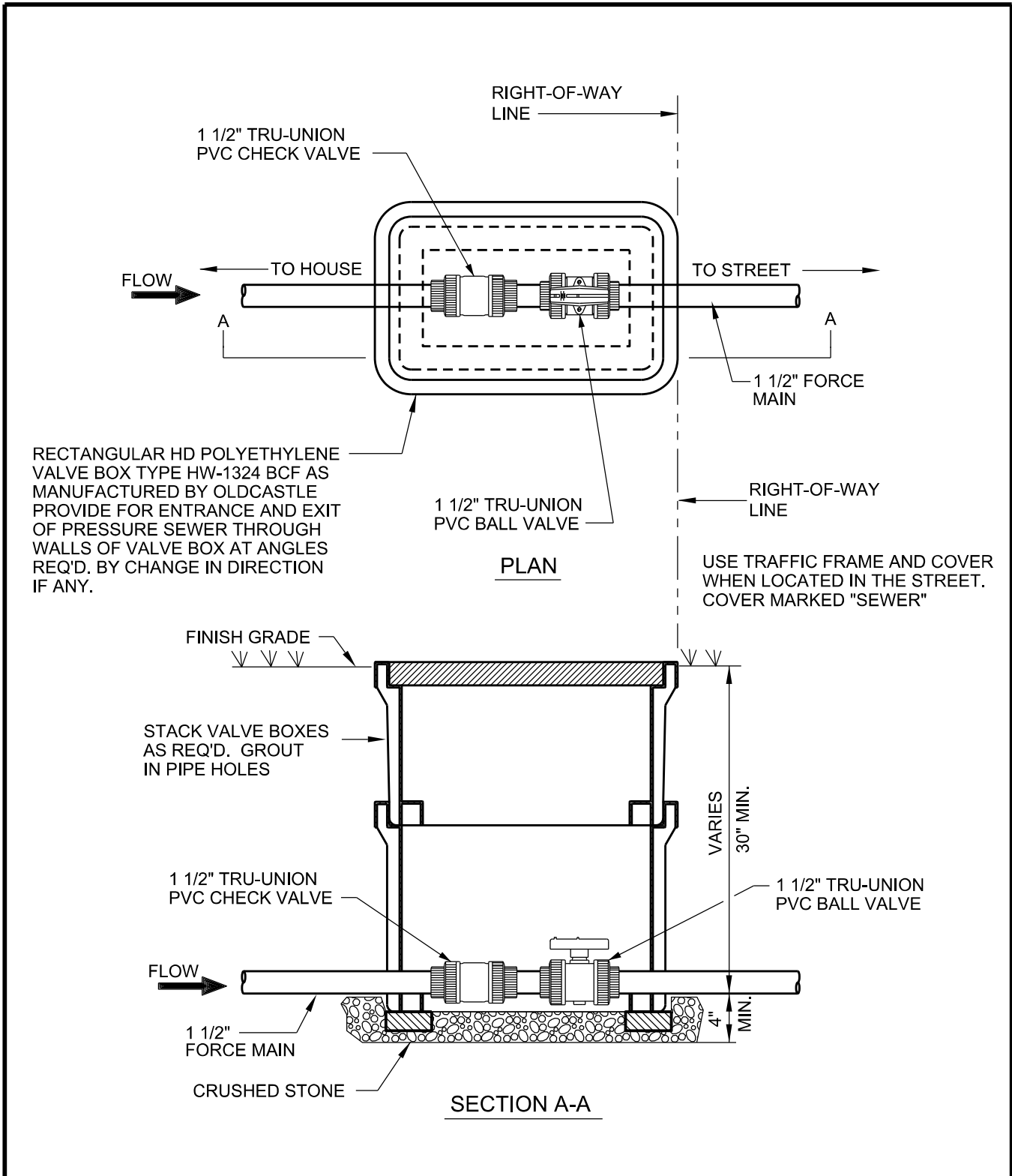

DATE: 07/2022

NOT TO SCALE

GRINDER PUMP SERVICE VALVE ASSEMBLY

STANDARD DETAIL

TOWN OF CHAPEL HILL
CHAPEL HILL, TENNESSEE

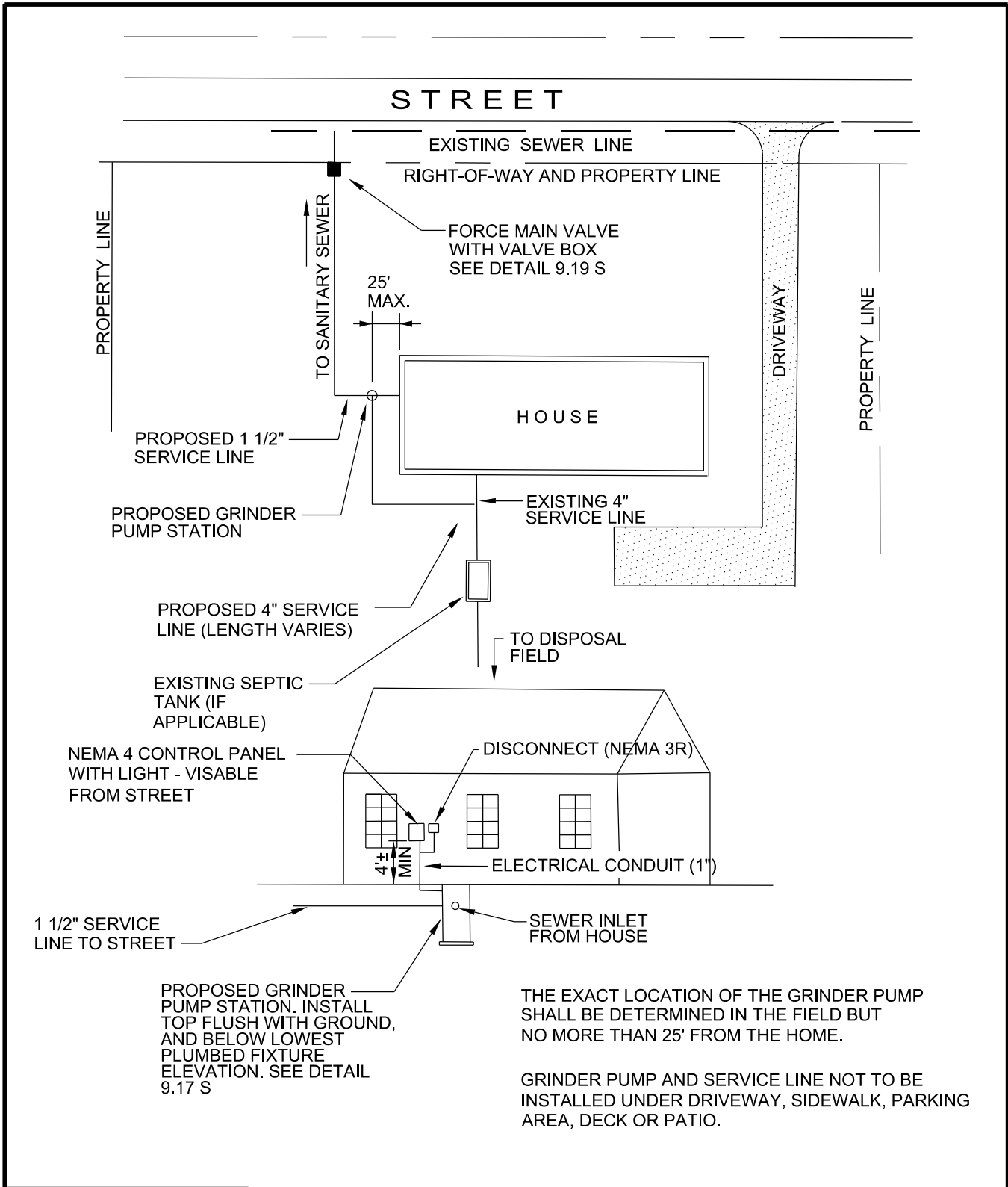

DATE: 07/2022

NOT TO SCALE

TYPICAL GRINDER PUMP LAYOUT

STANDARD DETAIL

TOWN OF CHAPEL HILL
CHAPEL HILL, TENNESSEE

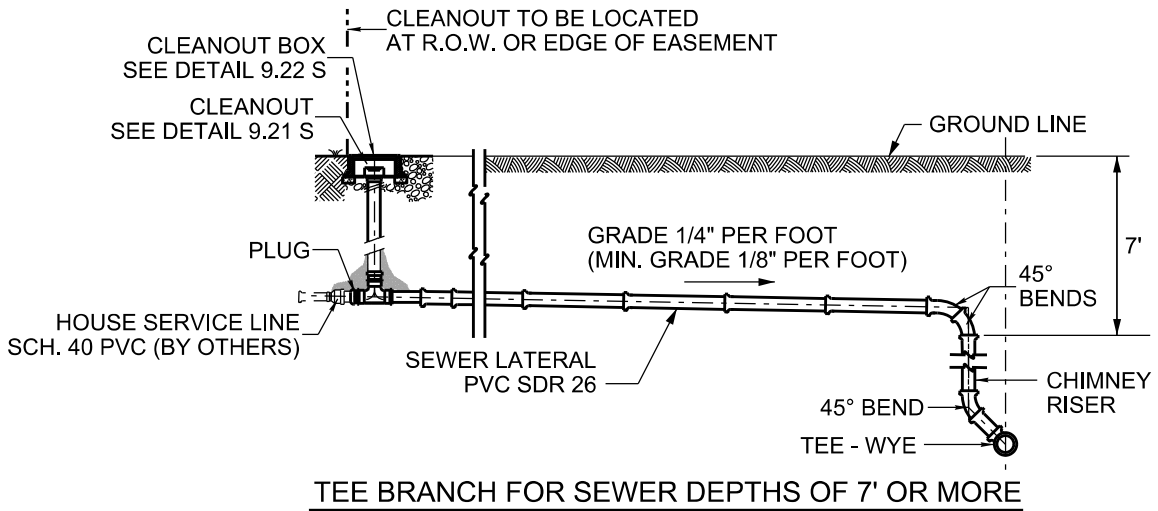
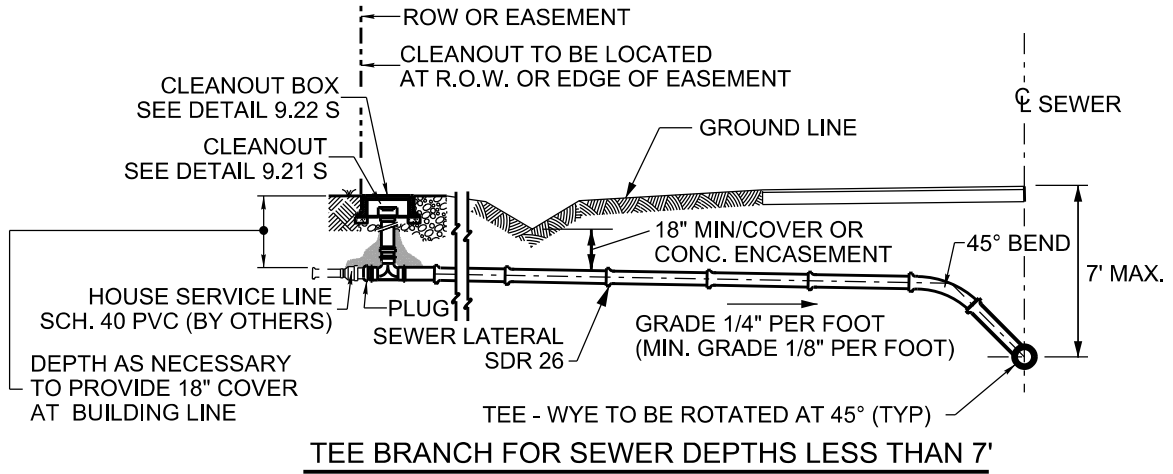

NOTES:

1. LATERAL SIZE TO BE 6" PVC SDR 26 SERVICES >6" MUST CONNECT AT A MANHOLE.
2. TEES SHALL BE SDR 26 WITH GASKETED BRANCHES OR MJ C153 DI TEE.
3. TEES SHALL NOT BE ORIENTED IN THE 12 O'CLOCK (STRAIGHT UP) POSITION.
4. TEES SHALL NOT BE PLACED BACK-TO-BACK. CONSECUTIVE TEES MUST BE SEPARATED BY AT LEAST 6 FT OF MAIN LINE PIPE.
5. PLACE TREATED 4"x 4" TIMBER, 42" LONG OR 2" SCH. 40 PVC PIPE FOR END OF SERVICE LOCATION. PAINT LOCATION MARKER GREEN.

DATE: 07/2022

NOT TO SCALE

SANITARY SEWER LATERALS

STANDARD DETAIL

TOWN OF CHAPEL HILL
CHAPEL HILL, TENNESSEE

9.21 S

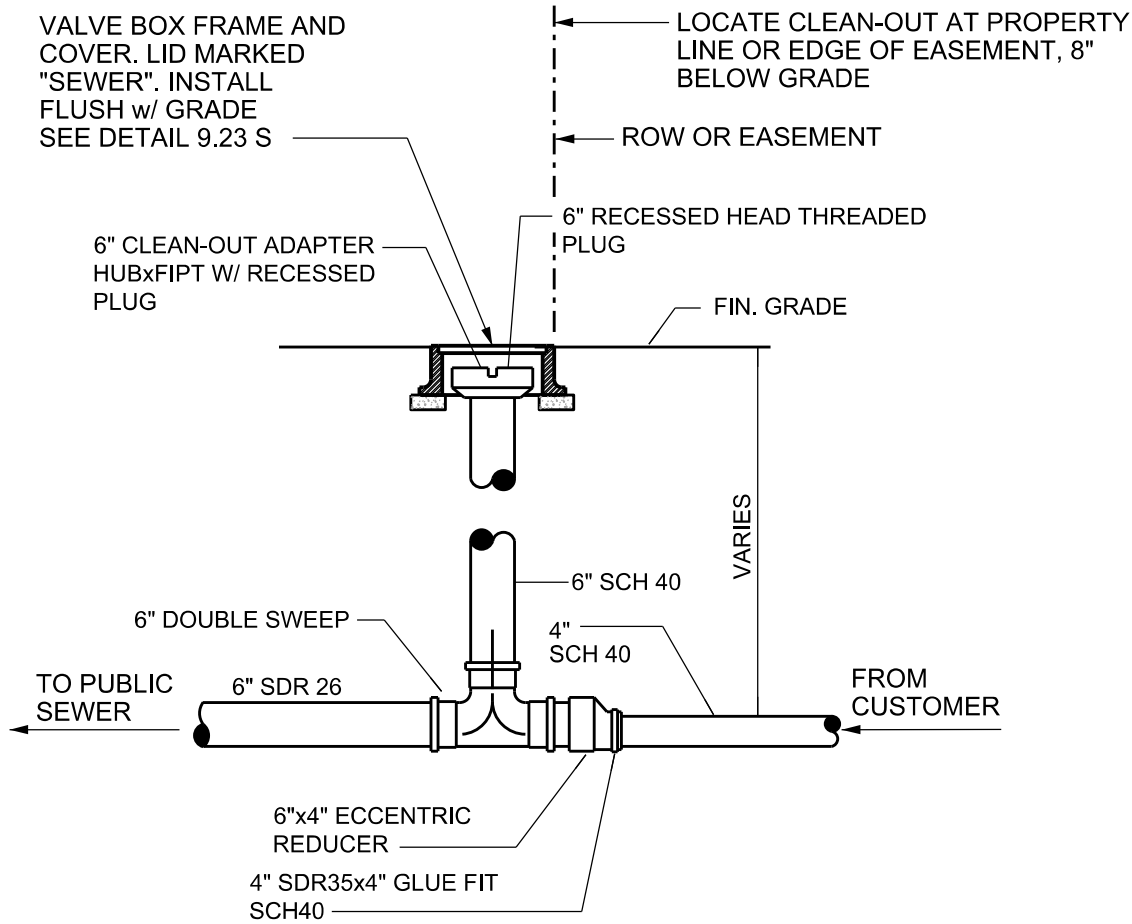

CLEAN-OUT

FITTING	PART No. *
6" DOUBLE SWEEP	G1006
6"x4" CONCENTRIC REDUCER	G1216
6" CLEAN-OUT ADAPTER HUB W/ COUNTERSUNK PLUG	P8406
6"x4" ECCENTRIC REDUCER	G1306
4" SDR35xSCH40 ADAPTER	P1213

* AS MANUFACTURED BY PLASTIC TRENDS, INC.
OR EQUIVALENT

DATE: 07/2022

NOT TO SCALE

LOT LINE SEWER SERVICE CONNECTION

STANDARD DETAIL

TOWN OF CHAPEL HILL
CHAPEL HILL, TENNESSEE

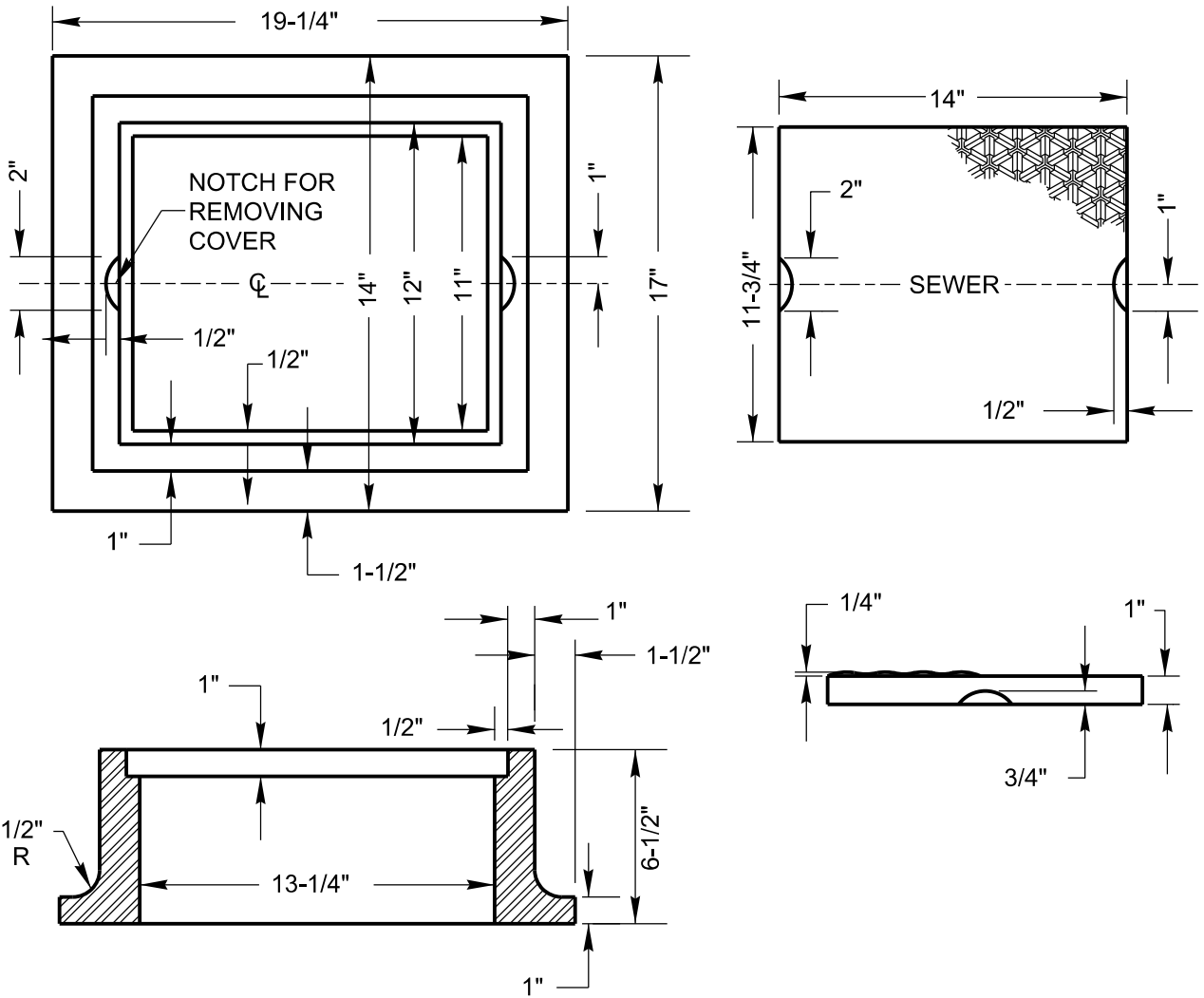

NOTES:

1. NO OPEN SAND CASTINGS, CASTINGS ARE TO BE MADE OF CAST IRON IN ACCORDANCE WITH CURRENT SPECIFICATIONS. COVER MUST FIT EVENLY ON RABBIT OF FRAME IN ORDER TO EQUALLY DISTRIBUTE WEIGHT OF COVER OVER FRAME MINIMUM WEIGHT OF FRAME 150 LBS. MINIMUM WEIGHT OF COVER 45 LBS.

DATE: 07/2022

NOT TO SCALE

**SANITARY SEWER CLEANOUT BOX
FRAME AND COVER**

STANDARD DETAIL

TOWN OF CHAPEL HILL
CHAPEL HILL, TENNESSEE

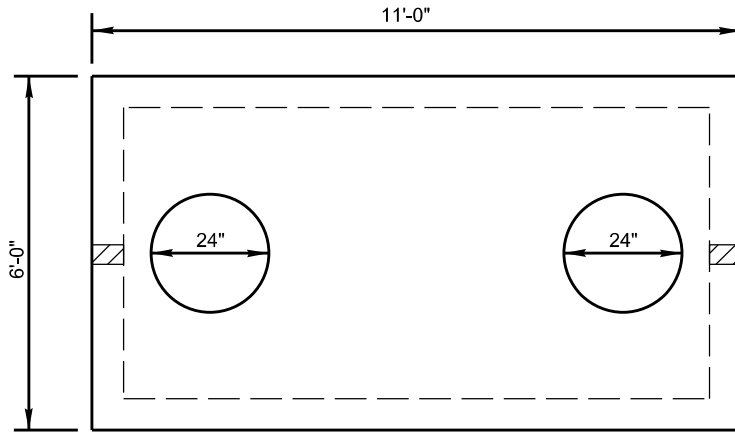

- GENERAL NOTES:**
1. CONCRETE: 28 DAY COMPRESSIVE STRENGTH $f_c = 4,500$ PSI
 2. STEEL REINFORCEMENT: ASTM A-615, GRADE 60
 3. COVER TO STEEL - 1" MINIMUM
 4. VAULTS ARE DESIGNED TO MEET ASTM C858 AND ACI 318 WITH AASHTO HS-20 LOADING
 5. EARTH COVER - 0 TO 2 FEET
 6. IF JOINT IS REQUIRED - JOINT TO BE DOUBLE SEALED WITH $1\frac{1}{4}$ " DIA. CONSEAL OR APPROVED EQUAL.
 7. TEST FOR WATER TIGHTNESS PER ASTM C1227

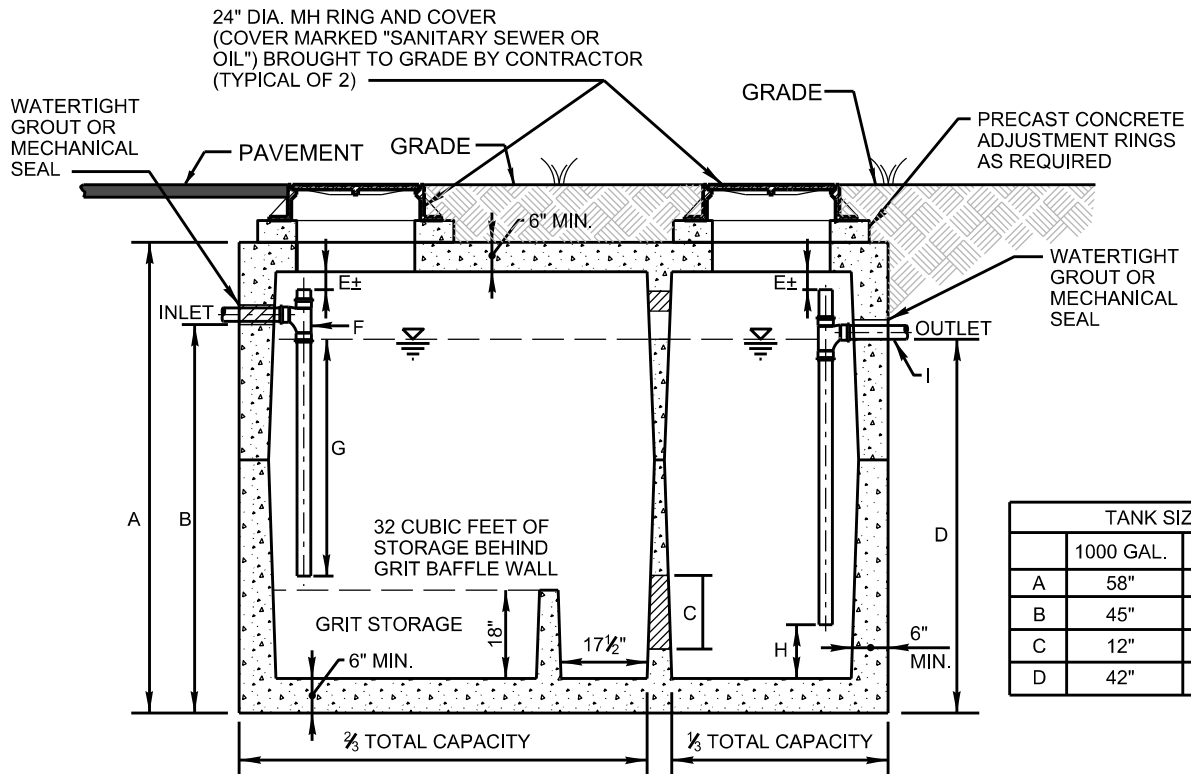

TANK SIZE		
	1000 GAL.	2000 GAL.
A	58"	95.75"
B	45"	79"
C	12"	15"
D	42"	76"

- E. MINIMUM 6", BUT NOT LESS THAN PIPE DIAMETER.
- F. INLET PIPE INVERT TO BE $2\frac{1}{2}$ " ABOVE LIQUID SURFACE.
- G. INLET PIPE TO TERMINATE $\frac{2}{3}$ DEPTH OF WATER LEVEL.
- H. 12" FROM FLOOR TO END OF OUTLET PIPE.
- I. OUTLET PIPE NO SMALLER THAN INLET PIPE, MINIMUM - 4"
- J. OLDCASTLE PRECAST OR C. R. BARGER & SONS ARE APPROVED MANUFACTURERS

DATE: 07/2022

NOT TO SCALE

TYPICAL OIL-WATER / GRIT INTERCEPTOR (1,000 OR 2,000 GAL.)

STANDARD DETAIL

TOWN OF CHAPEL HILL
CHAPEL HILL, TENNESSEE

NOTE:
 REFER TO TOWN OF CHAPEL HILL
 FATS, OILS & GREASE (FOG)
 MANAGEMENT POLICY FOR
 SPECIFICATIONS AND
 ADDITIONAL REQUIREMENTS.

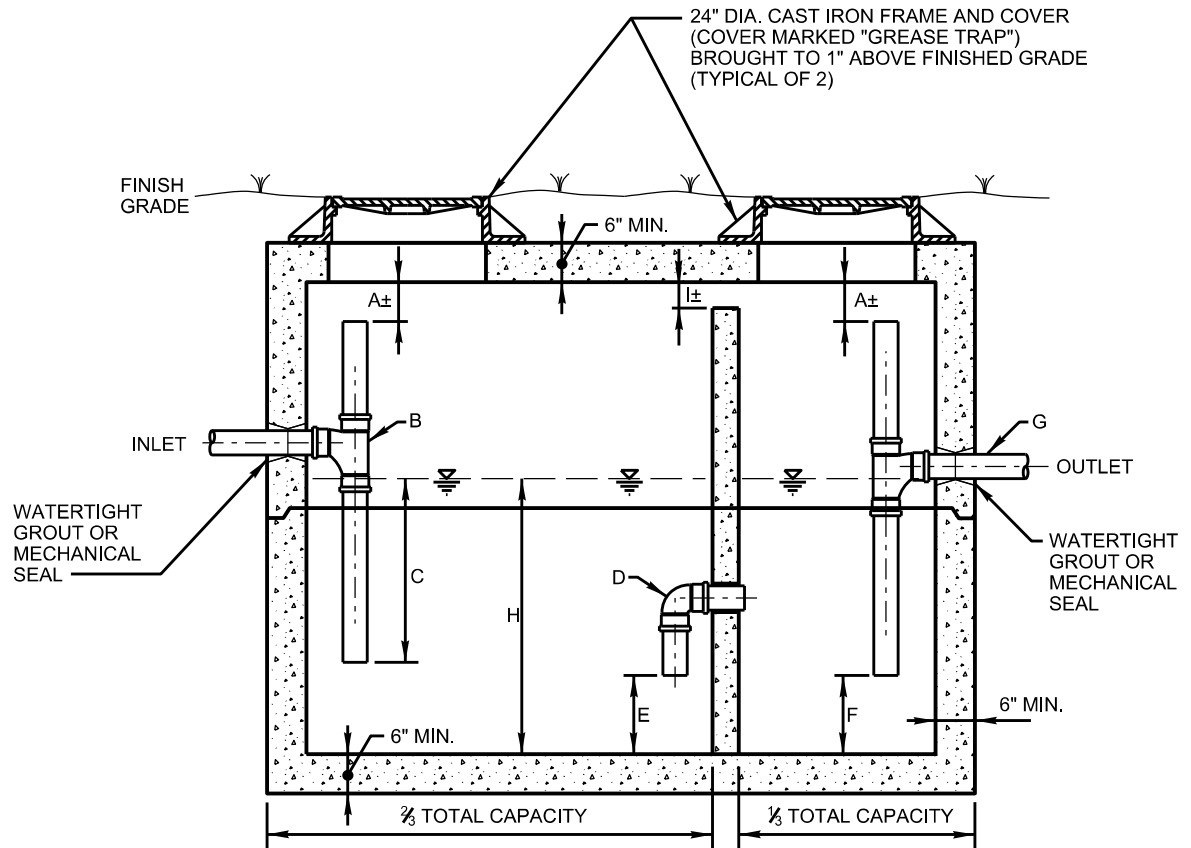

- A. MINIMUM 6", BUT NOT LESS THAN PIPE DIAMETER.
- B. INLET PIPE INVERT TO BE $2\frac{1}{2}$ " ABOVE LIQUID SURFACE.
- C. INLET PIPE TO TERMINATE $\frac{2}{3}$ DEPTH OF WATER LEVEL.
- D. 90 DEGREE SWEEP, MINIMUM SIZE - 6"
- E. 12" FROM FLOOR TO END OF SWEEP.
- F. 12" FROM FLOOR TO END OF OUTLET PIPE.
- G. OUTLET PIPE NO SMALLER THAN INLET PIPE, MINIMUM - 4"
- H. MINIMUM DEPTH OF LIQUID CAPACITY - 42"
- I. MAXIMUM DISTANCE FROM CEILING - 6"
- J. OLDCASTLE PRECAST OR C. R. BARGER & SONS ARE APPROVED MANUFACTURERS

DATE: 07/2022

NOT TO SCALE

TYPICAL GREASE INTERCEPTOR (1,000 OR 2,000 GAL.)

STANDARD DETAIL

TOWN OF CHAPEL HILL
 CHAPEL HILL, TENNESSEE

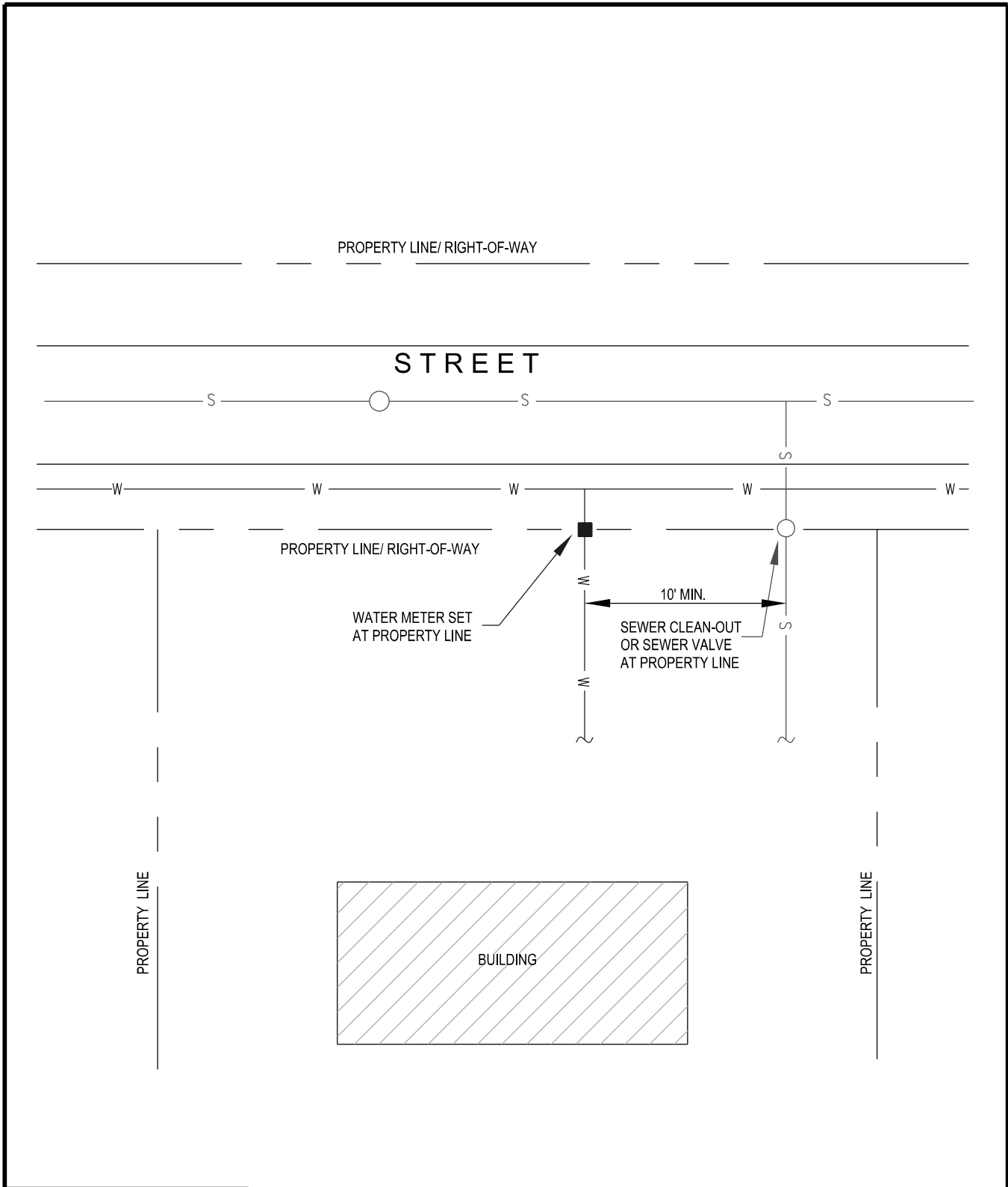

DATE: 07/2022

NOT TO SCALE

TYPICAL WATER & SEWER SERVICE SEPERATION

STANDARD DETAIL
 TOWN OF CHAPEL HILL
 CHAPEL HILL, TENNESSEE

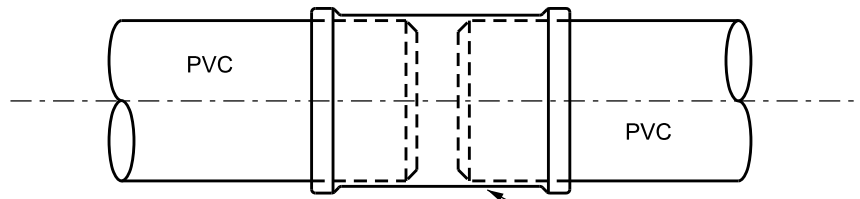

PVC KNOCK - ON (COMPRESSION) FITTING

NOTES:

1. CUT AND BEVEL NEW PIPE TO FIT THE GAP OF THE REPAIR SECTION.
2. INSTALL REPAIR COUPLING ON PIPE SECTION.
3. BEVEL ENDS OF EXISTING PIPE.
4. MARK EXISTING PIPE AS A GUIDE TO CENTER COUPLING OVER JOINT.
5. ALIGN AND SLIDE REPAIR COUPLINGS OVER THE ORIGINAL PIPE TO MARKS CENTERING COUPLINGS OVER THE CUT.

METHOD 1

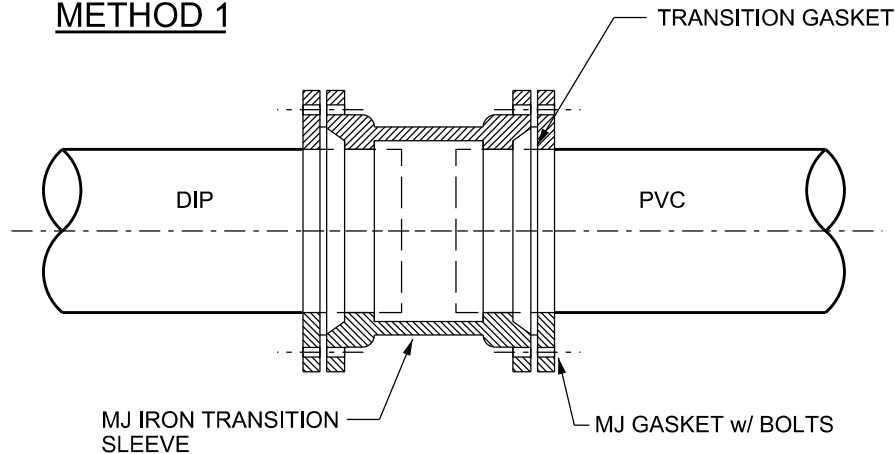

NOTES:

1. TRANSITION SLEEVES SHALL BE SOLID, MECHANICAL JOINT, LONG PATTERN FITTINGS. AWWA C153, OR PVC GASKETED, COMPRESSION COUPLING.
2. FLEXIBLE COUPLINGS (FERNCOS) ARE NOT PERMITTED.
3. TOWN OF CHAPEL HILL SHALL APPROVE ALTERNATE TRANSITION METHODS.

METHOD 2

DATE: 07/2022

NOT TO SCALE

**TYPICAL SEWER LINE
REPAIR TRANSITION**

STANDARD DETAIL

TOWN OF CHAPEL HILL
CHAPEL HILL, TENNESSEE

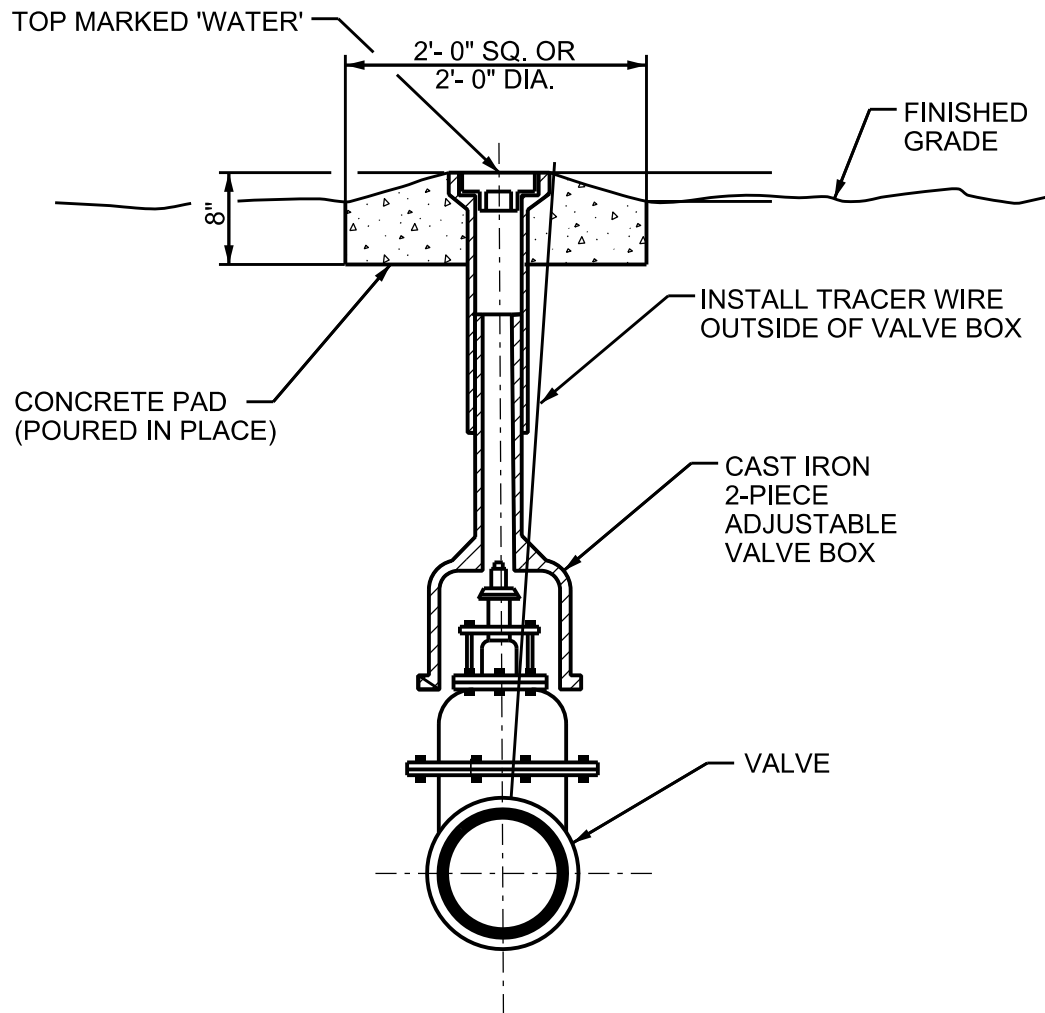

NOTES:

1. ALL PIPE LOCATED BETWEEN VALVES AND FITTINGS WHICH HAS A LENGTH OF 5' OR LESS SHALL BE DIP, OR A FOSTER ADAPTOR SHALL BE USED.
2. CAST AROUND THE TOP OF EACH BOX A CONCRETE COLLAR 2'-0" IN DIAMETER OR 2'-0" SQUARE AND 8" THICK WHEN VALVES ARE LOCATED IN UNPAVED AREAS. NOT REQUIRED IN PAVED AREAS.

DATE: 07/2022

NOT TO SCALE

TYPICAL VALVE BOX SETTING

STANDARD DETAIL

TOWN OF CHAPEL HILL
CHAPEL HILL, TENNESSEE

NOTES:

1. INSTALL NEW 6" GATE VALVE
2. ALL PIPE LOCATED BETWEEN VALVES AND FITTINGS WHICH HAS A LENGTH 5 FEET OR LESS SHALL BE DIP, OR USE A FOSTER ADAPTOR.
3. HYDRANT SHALL BE 5 1/4 M&H FIRE HYDRANT

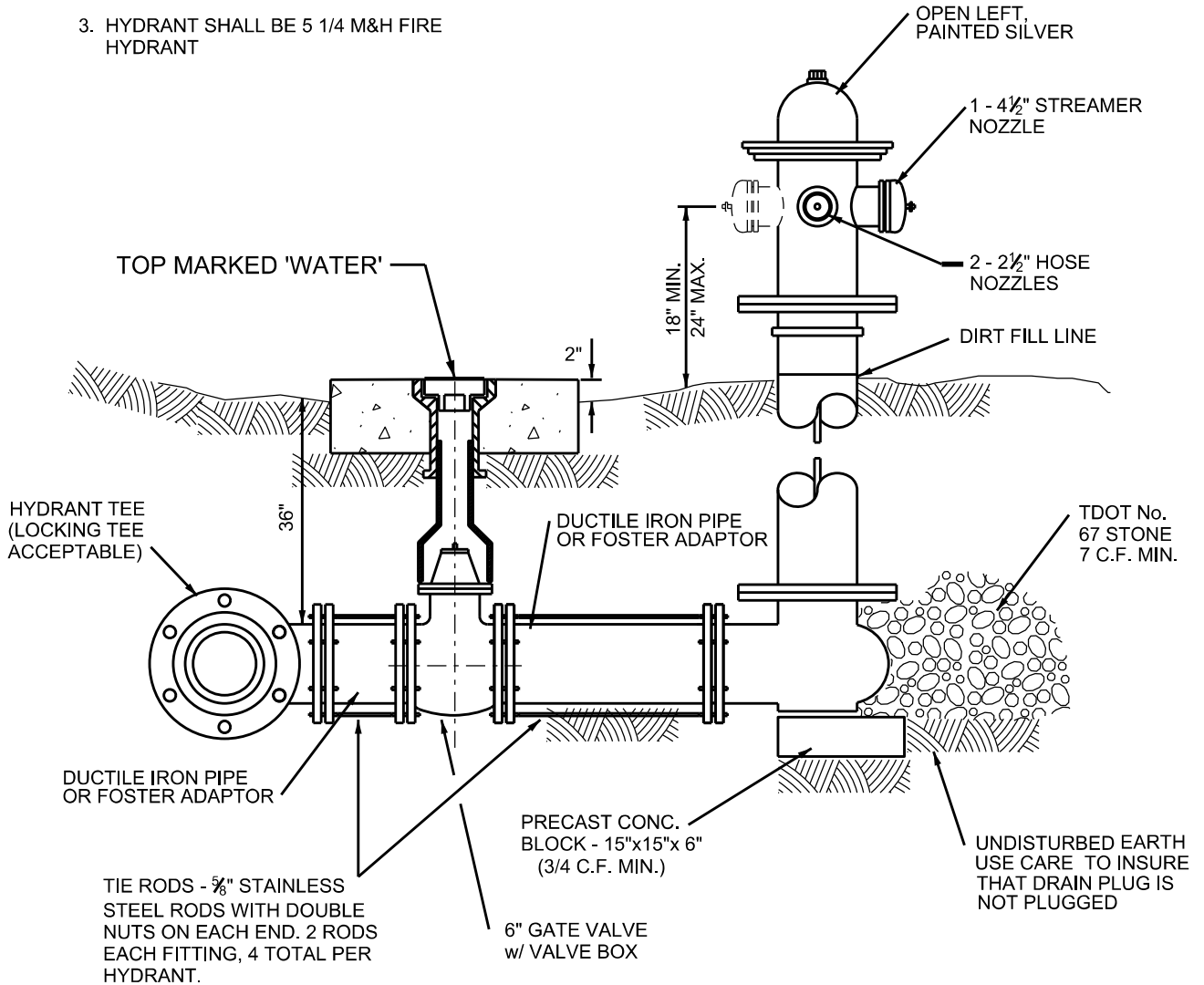

DATE: 07/2022

NOT TO SCALE

TYPICAL FIRE HYDRANT SETTING

STANDARD DETAIL

TOWN OF CHAPEL HILL
CHAPEL HILL, TENNESSEE

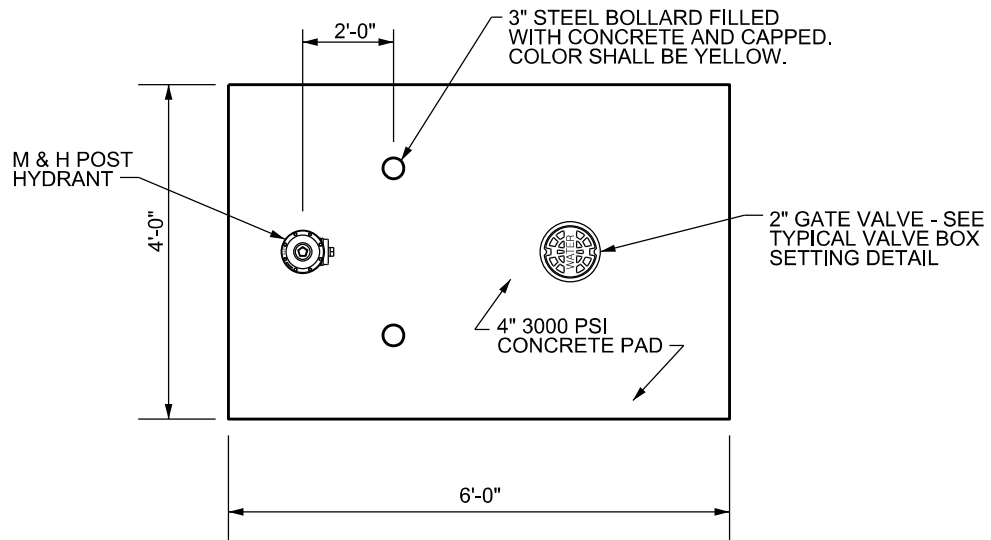

NOTE:

1. INSTALL TWO (2) 3" DIAMETER STAINLESS STEEL BOLLARD POSTS ON EACH SIDE OF THE HYDRANT IN A PARALLEL FASHION WITH RESPECT TO ROADWAY. BOLLARDS TO BE FILLED WITH CONCRETE AND SHALL BE YELLOW IN COLOR.

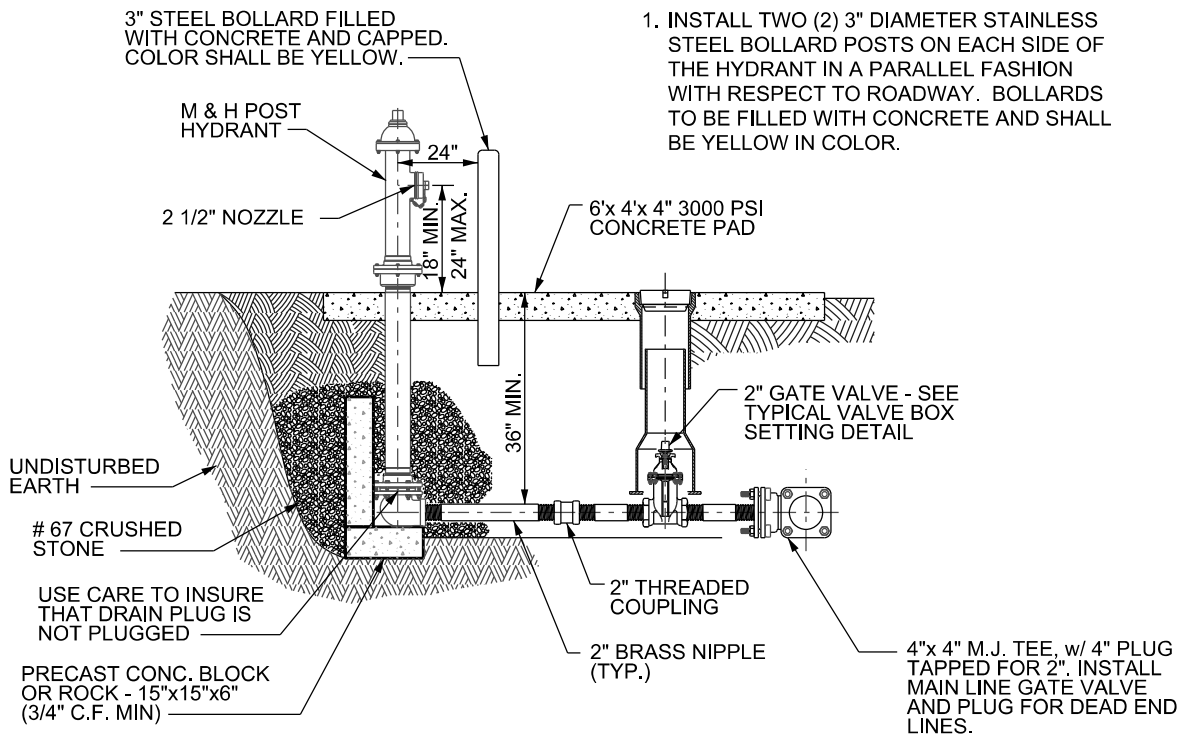

DATE: 07/2022

NOT TO SCALE

POST HYDRANT DETAIL

STANDARD DETAIL

TOWN OF CHAPEL HILL
CHAPEL HILL, TENNESSEE

9.03 W

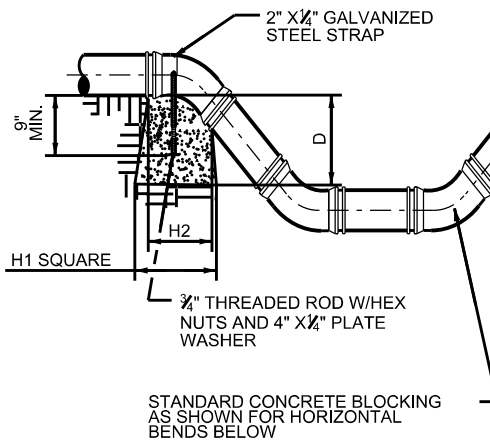

VERTICAL BENDS

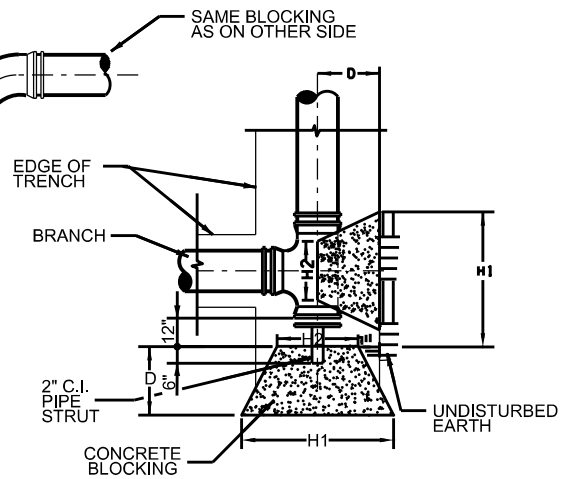

TEES, CROSSES AND PLUGS

NOTE: DIMENSIONS ARE CONTROLLED BY DIAMETER OF BRANCH MAIN.

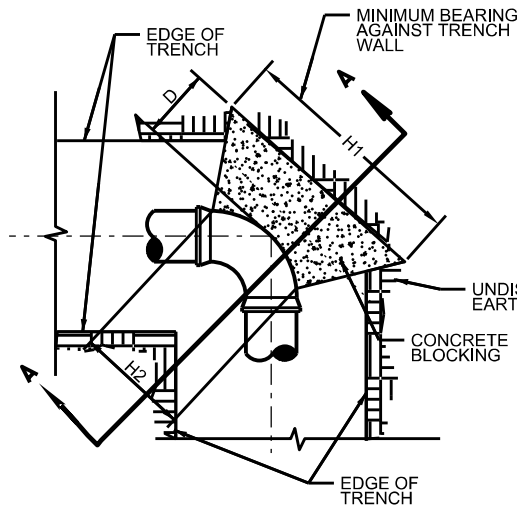

HORIZONTAL BENDS

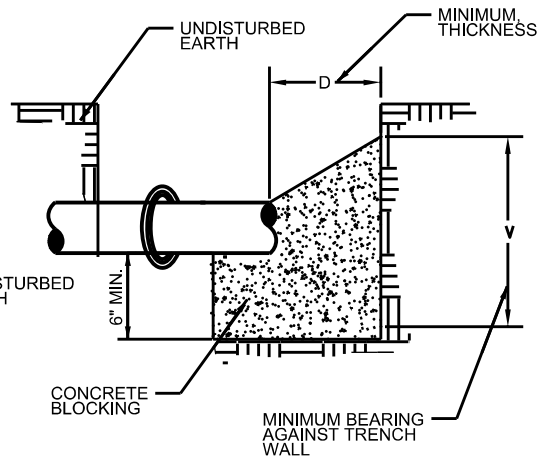

SECTION A-A

NOTES:
 FITTING RESTRAINT DEVICES MAY BE INSTALLED IF DIRECTED BY THE OWNER.
 IF RESTRAINING DEVICES ARE INSTALLED, CONCRETE THRUST BLOCKS ARE NOT REQUIRED.
 CONCRETE USED FOR BLOCKING SHALL BE 3,500 PSI. EARTH PRESSURES ARE CALCULATED FOR 4,000 PSF SOIL. BEARING AREAS OF THRUST BLOCKS SHALL BE INCREASED WHEN POURED IN SAND, LOOSE FILL OR WET EARTH. TABLE IS BASED ON 225 PSI OR 150 PSI WORKING PRESSURE PLUS 50% WATER HAMMER

TEES, CROSSES & PLUGS					90° BENDS					45° BENDS					22½° BENDS					11¼° BENDS					PIPE SIZE					
H1	H2	V	D	C.F.	H1	H2	V	D	C.F.	H1	H2	V	D	C.F.	H1	H2	V	D	C.F.	H1	H2	V	D	C.F.						
24"	12"	12"	18"	2.25	24"	12"	12"	18"	2.25	18"	8"	12"	18"	1.60	18"	8"	12"	18"	1.60	18"	8"	12"	18"	1.60	18"	8"	12"	18"	1.60	3" & 4"
24"	16"	18"	18"	3.50	30"	16"	18"	18"	4.05	24"	10"	16"	18"	3.20	24"	10"	16"	18"	3.20	24"	10"	16"	18"	3.20	24"	10"	16"	18"	3.20	6"
36"	18"	18"	18"	5.05	39"	18"	24"	18"	7.30	30"	11"	18"	18"	3.95	30"	11"	18"	18"	3.95	24"	11"	16"	18"	3.40	24"	11"	16"	18"	3.40	8"
48"	24"	18"	24"	7.15	54"	32"	24"	18"	10.25	24"	18"	21"	18"	4.60	24"	18"	21"	18"	4.60	24"	18"	21"	18"	4.60	24"	18"	21"	18"	4.60	10"
54"	30"	24"	24"	13.4	54"	32"	36"	24"	18.15	42"	18"	24"	24"	9.60	24"	18"	24"	24"	6.60	24"	18"	21"	24"	6.10	24"	18"	21"	24"	6.10	12"

DATE: 07/2022

NOT TO SCALE

TYPICAL CONCRETE THRUST BLOCKING

STANDARD DETAIL

TOWN OF CHAPEL HILL
 CHAPEL HILL, TENNESSEE

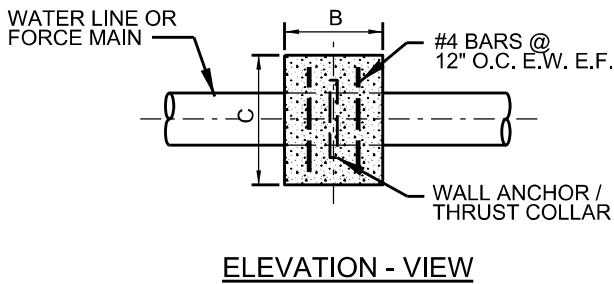
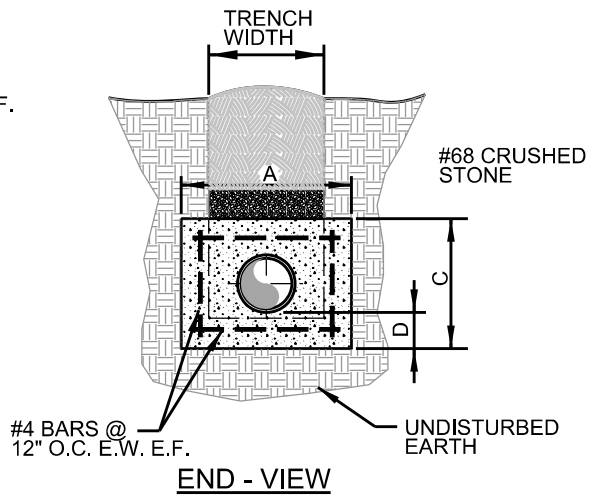
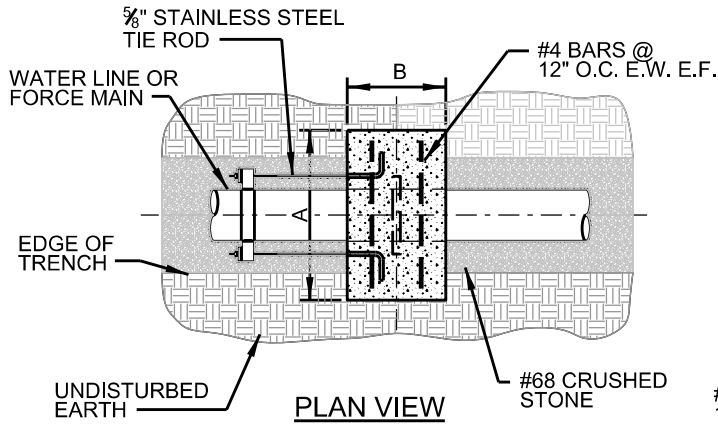

MINIMUM DIMENSIONS FOR CONCRETE COLLAR						
PIPE SIZE	A	B	C	D	VOLUME CU. YDS	THRUST
3"	3'-0"	3'-0"	1'-7"	0'-8"	0.35	1,770
4"	3'-6"	3'-0"	2'-0"	0'-9"	0.77	3,140
6"	4'-0"	3'-0"	2'-7"	1'-0"	1.15	7,070
8"	4'-6"	3'-0"	3'-0"	1'-3"	1.5	12,570
10"	5'-2"	3'-0"	3'-2"	1'-3"	1.18	19,635
12"	5'-9"	3'-0"	3'-8"	1'-8"	2.34	28,775
14"	6'-6"	3'-0"	4'-0"	1'-9"	2.89	38,490
16"	6'-9"	3'-0"	4'-9"	2'-3"	3.56	50,270
24"	8'-9"	3'-0"	8'-9"	3'-3"	8.16	113,100

NOTES:

1. THIS STANDARD DETAIL IS FOR DEADMAN BLOCKING ONLY.
2. SOIL CONDITIONS MUST BE VERIFIED BY THE INSPECTOR BEFORE THRUST COLLAR IS POURED.
3. FORMWORK ALLOWED WITHIN TRENCH SECTION ONLY. CONCRETE MUST BE POURED AGAINST UNDISTURBED SOIL OUTSIDE OF STANDARD TRENCH SECTION.
4. BOTTOM OF BLOCK IS TO BE ON UNDISTURBED SOIL.
5. TRENCH TO BE BACKFILLED WITH CRUSHED ROCK COMPACTED TO 95% DENSITY ON ALL SIDES OF BLOCK AND A DISTANCE OF 4" MINIMUM IN FRONT OF BLOCK TO FULL DEPTH OF BLOCK.
6. MAINTAIN 18" MINIMUM COVER OVER THE TOP OF THE BLOCK.
7. CONCRETE SHALL BE 3000 PSI.
8. UNDER ADVERSE CONDITIONS, CONCRETE SHALL BE HIGH EARLY.
9. CONCRETE TO BE POURED 16 HOURS, BEFORE BACKFILL IS PLACED AND IN SUCH A MANNER SO AS TO PREVENT FLOATING.
10. DESIGN BASED ON 2000 PSF SOIL BEARING PRESSURE AND 250 PSI TEST PRESSURE.

DATE: 07/2022

NOT TO SCALE

DEADMAN THRUST RESTRAINT

STANDARD DETAIL

TOWN OF CHAPEL HILL
CHAPEL HILL, TENNESSEE

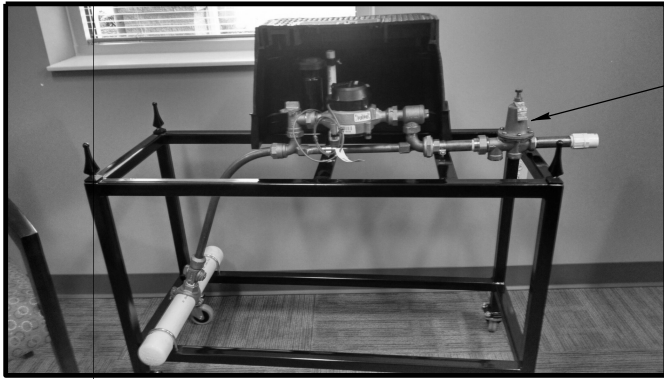

PRESSURE REDUCING VALVE
(CUSTOMERS RESPONSIBILITY)

CARSON MODEL 1015
HDPE METER BOX, LID
MODEL 10154075 WITH
TOUCH READ HOLE

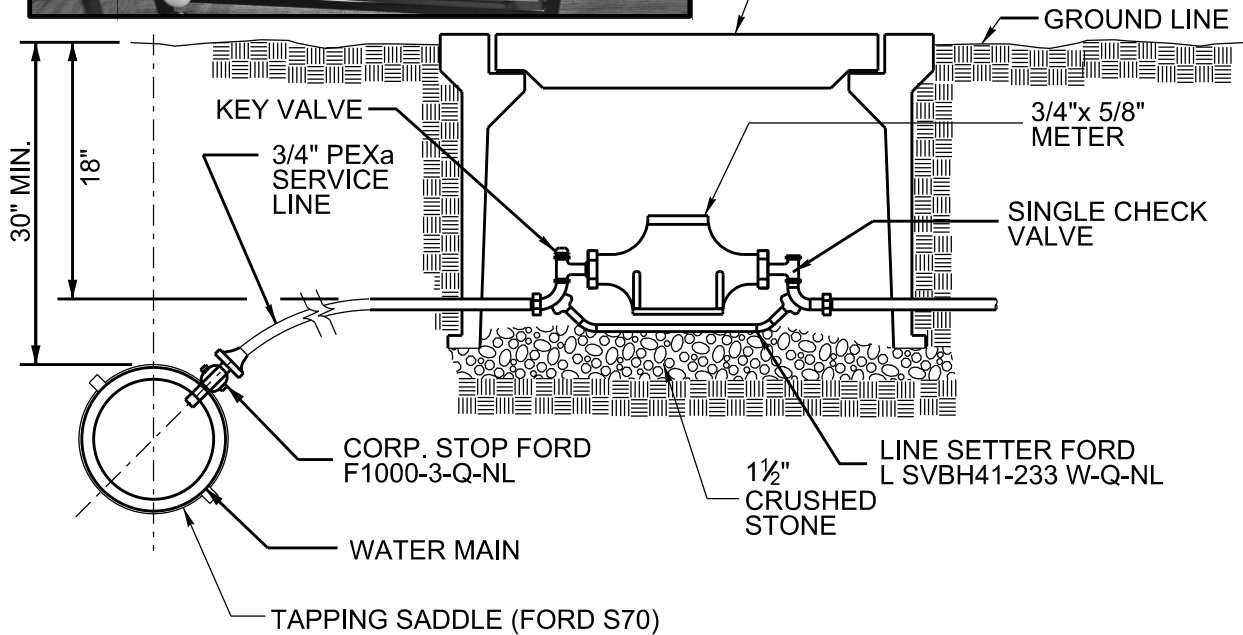

NOTES:

1. FOR TAPS IN PVC OR DIP PIPE USE TAPPING SADDLE.
2. SERVICES UNDER EXISTING ROADWAY ARE TO BE BORED AND JACKED. SERVICE LINE UNDER PAVEMENT TO BE INSTALLED INSIDE 2" HDPE (CONTINUOUS) CARRIER PIPE ON 3/4" SERVICE.
3. REFER TO STANDARD SPECIFICATIONS FOR TECHNICAL REQUIREMENTS OF EACH ITEM.
4. WATER TAPS ON NEW WATER MAINS TO BE MADE BY CONTRACTOR. WATER TAPS ON EXISTING WATER MAINS WILL BE MADE BY TOWN OF CHAPEL HILL.

DATE: 07/2022

NOT TO SCALE

3/4" SERVICE ASSEMBLY

STANDARD DETAIL

TOWN OF CHAPEL HILL
CHAPEL HILL, TENNESSEE

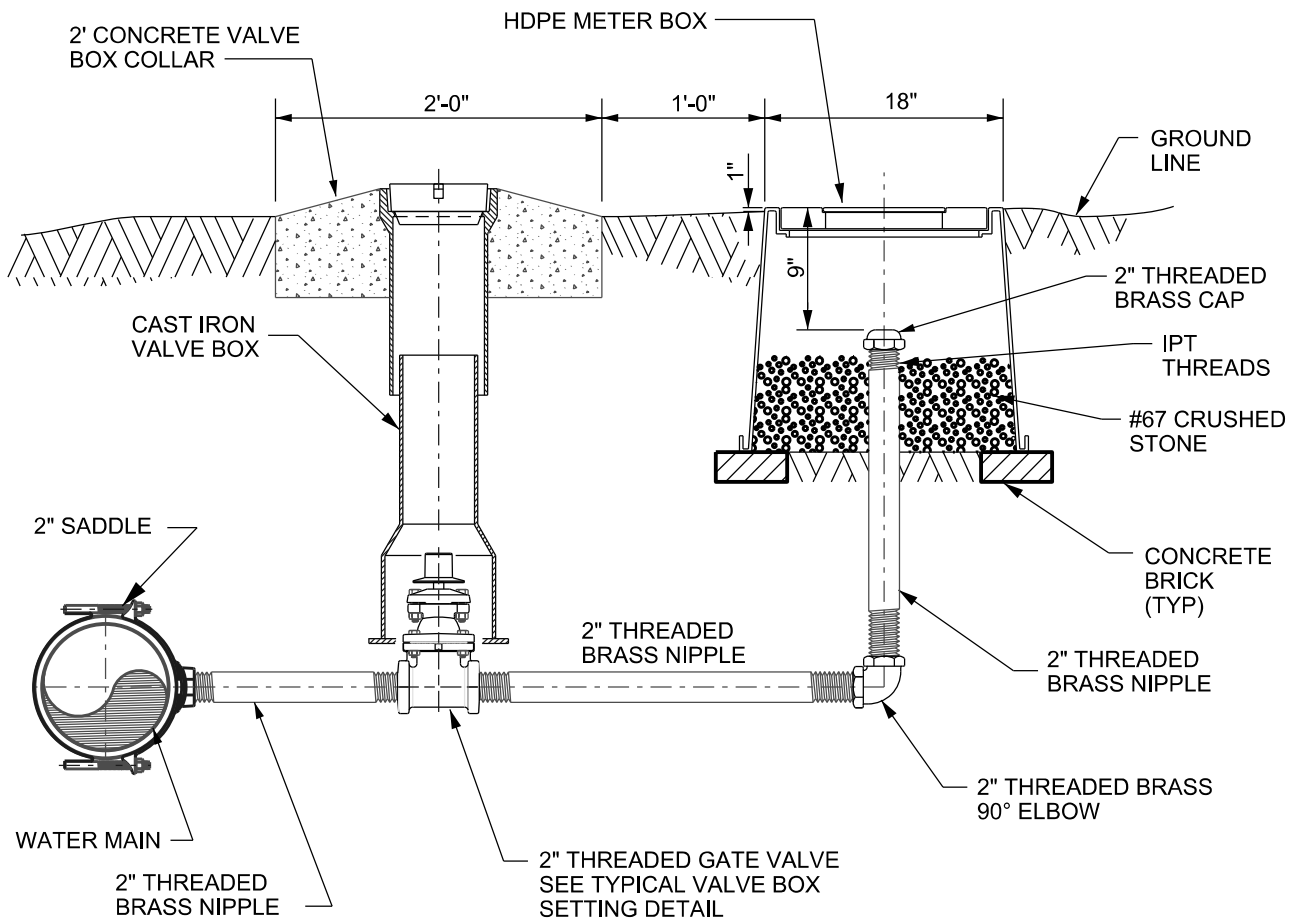

DATE: 07/2022

NOT TO SCALE

2" BLOWOFF DETAIL

STANDARD DETAIL

TOWN OF CHAPEL HILL
CHAPEL HILL, TENNESSEE

9.07 W

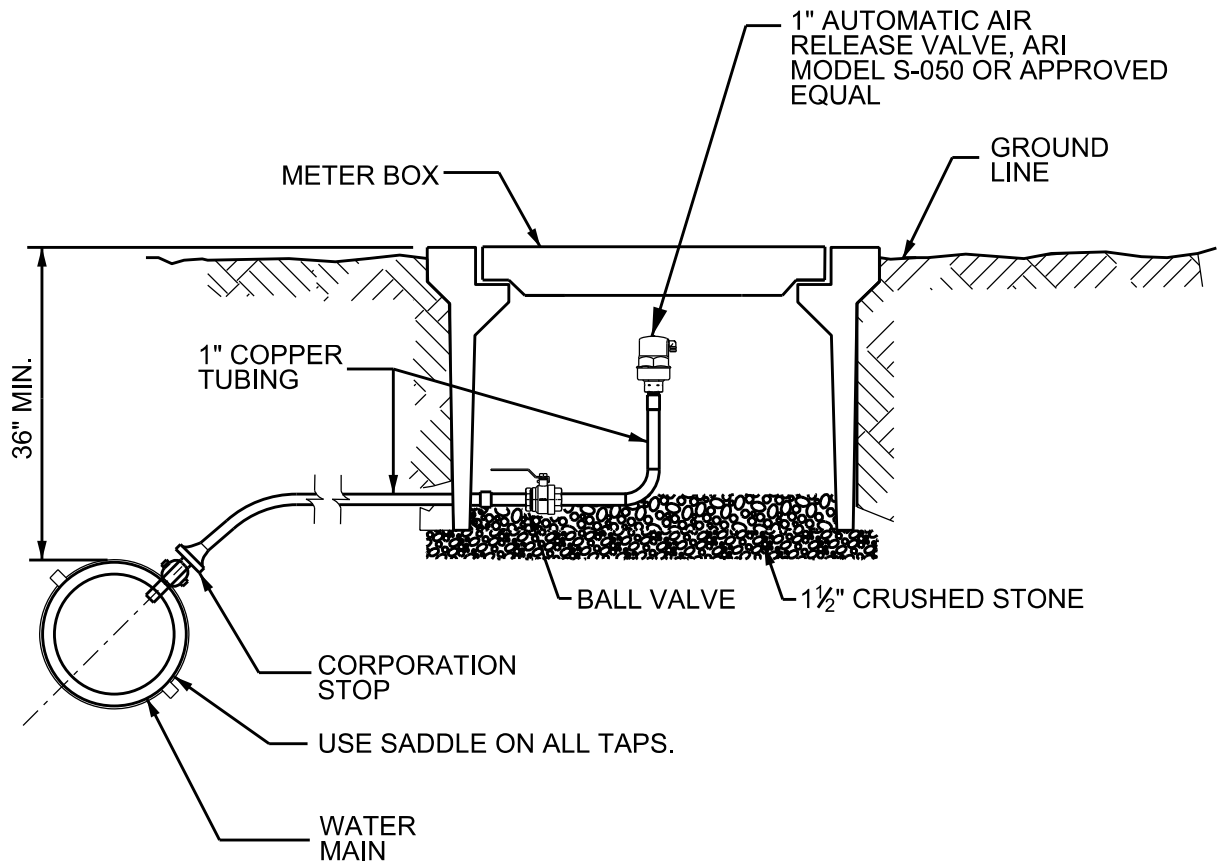

NOTES:

1. IF PIPE IS IN ROADWAY, AIR RELEASE ASSEMBLY SHALL BE LOCATED OUTSIDE ROADWAY.
2. ASSEMBLY SHALL BE LOCATED AT HIGH POINT OF WATER MAIN AS DIRECTED BY TOWN OF CHAPEL HILL.
3. AIR RELEASE ASSEMBLIES SHALL ONLY BE USED WHERE FIRE HYDRANT SPACING DOES NOT PROVIDE DOE AIR RELEASE AT HIGH POINT.

DATE: 07/2022

NOT TO SCALE

1" AUTOMATIC AIR RELEASE ASSEMBLY

STANDARD DETAIL

TOWN OF CHAPEL HILL
CHAPEL HILL, TENNESSEE

NOTE:
30" MIN. COVER FOR ALL
WATER LINES UNLESS
OTHERWISE SHOWN.

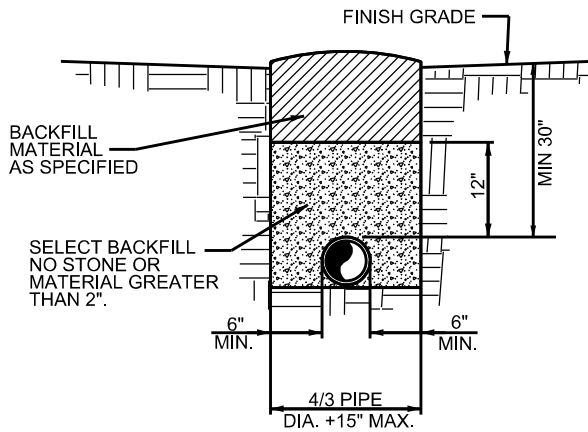

**DUCTILE IRON PIPE
IN EARTH**

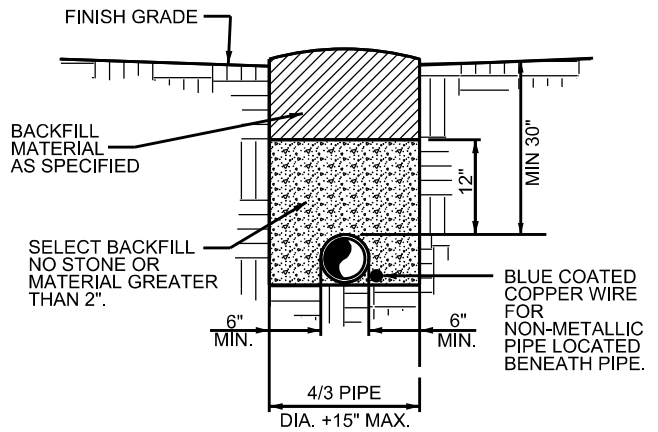

**PVC PIPE
IN EARTH**

- NOTE:
1. UNTIL FINAL SURFACE PAVEMENT RESTORATION, INSTALL AND MAINTAIN CRUSHER RUN FLUSH WITH EXISTING PAVEMENT.
 2. ALL PAVEMENT REPAIR MUST MEET THE REQUIREMENTS OF THE GOVERNING HIGHWAY DEPARTMENT (LOCAL COUNTY OR STATE).

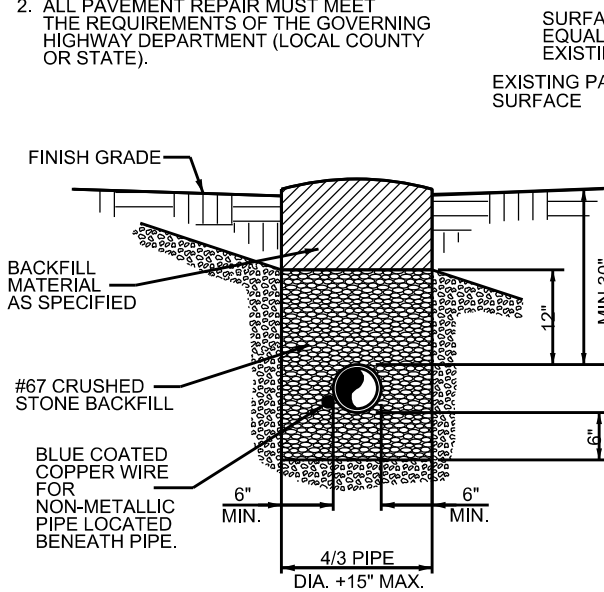

**ALL PIPE
(DUCTILE IRON OR PVC)
IN ROCK**

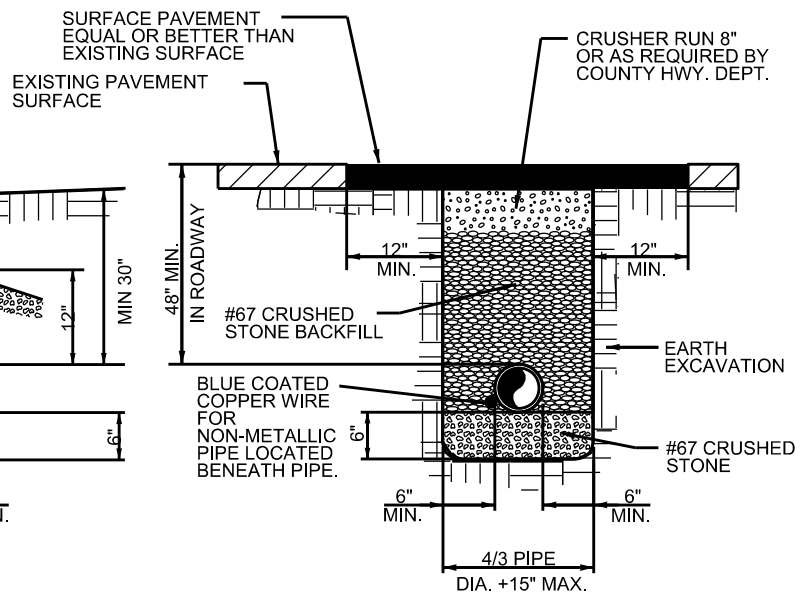

**ALL PIPE
IN TRAFFIC AREAS**

DATE: 07/2022

NOT TO SCALE

STANDARD WATER MAIN BEDDING AND BACKFILLING

STANDARD DETAIL

TOWN OF CHAPEL HILL
CHAPEL HILL, TENNESSEE

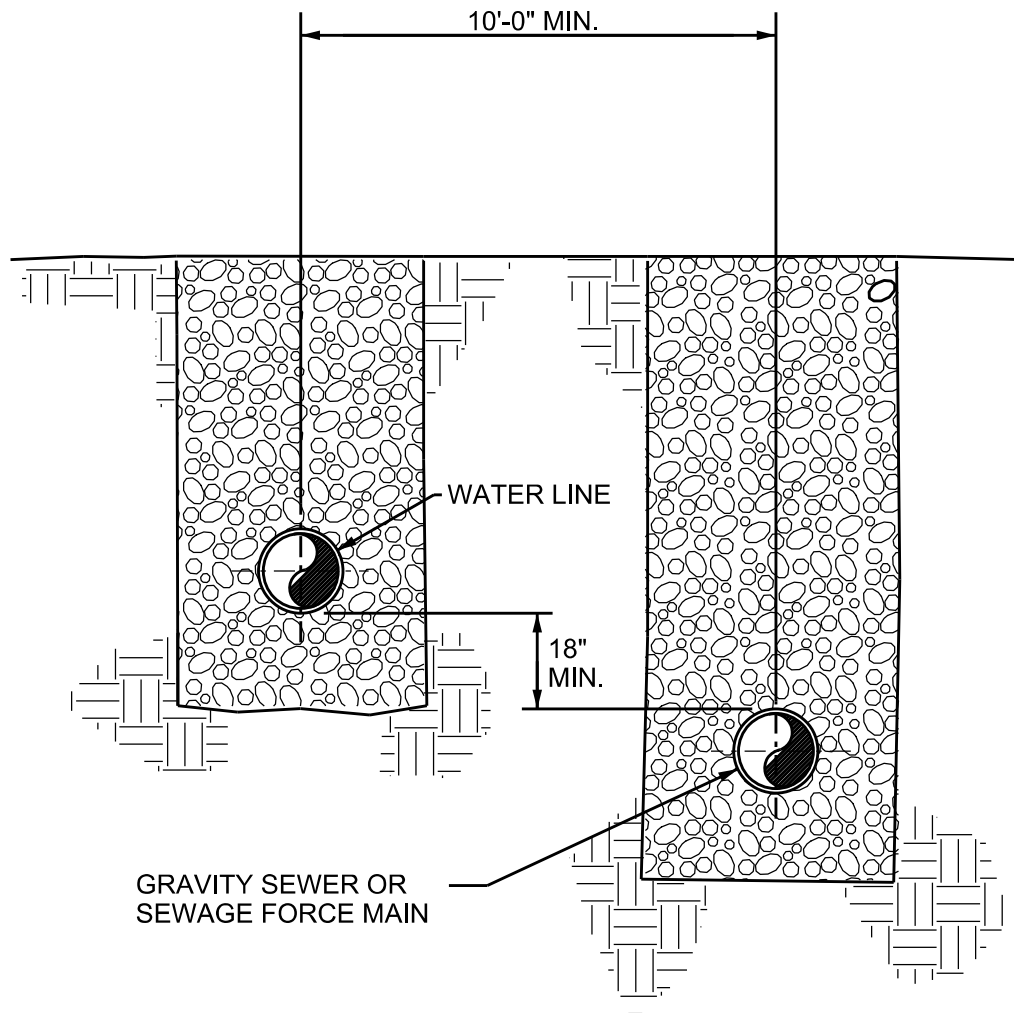

DATE: 07/2022

NOT TO SCALE

UTILITY SEPERATION DETAIL

STANDARD DETAIL

TOWN OF CHAPEL HILL
CHAPEL HILL, TENNESSEE

9.10 W

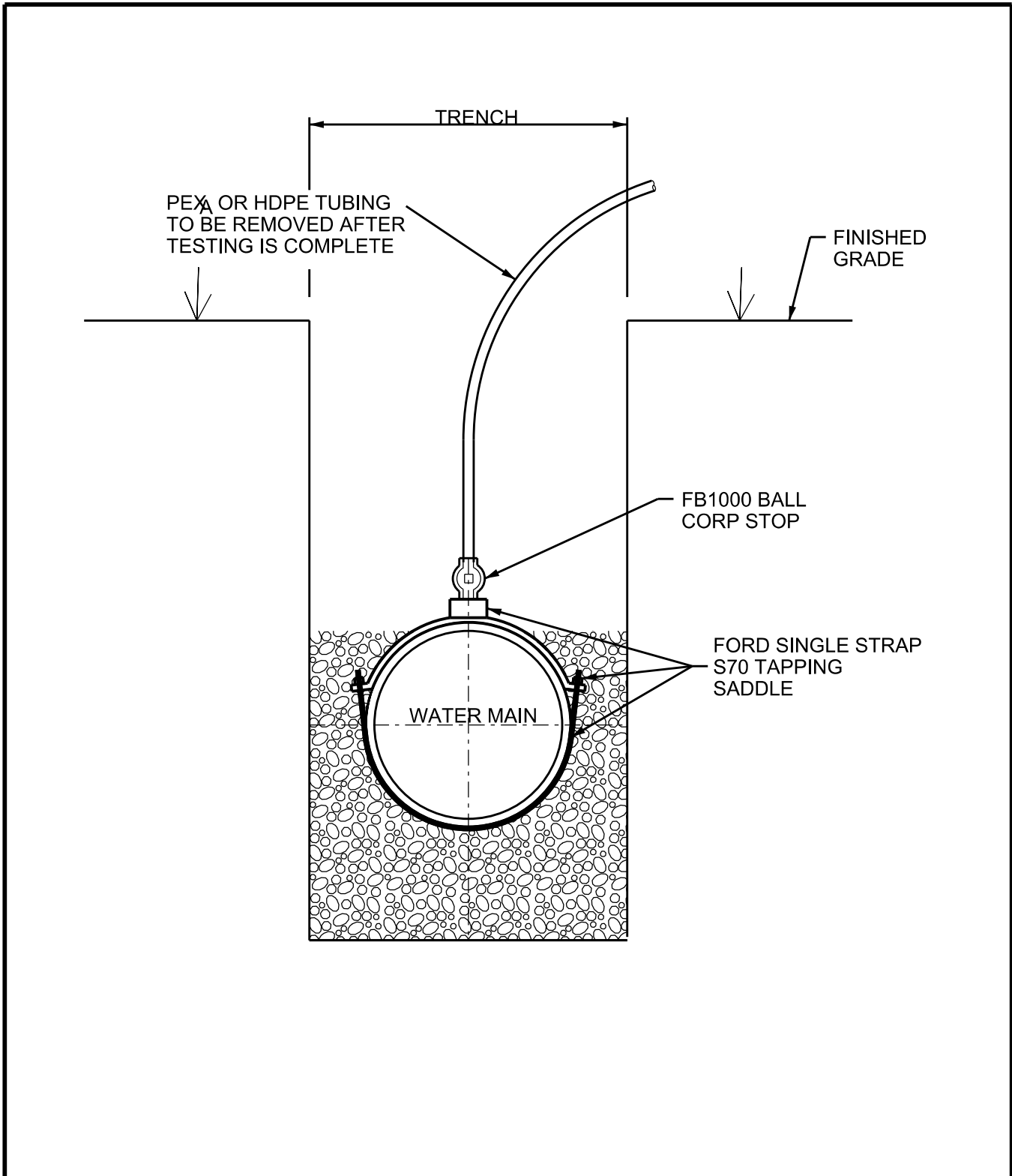

DATE: 07/2022

NOT TO SCALE

UTILITY SEPERATION DETAIL

STANDARD DETAIL
 TOWN OF CHAPEL HILL
 CHAPEL HILL, TENNESSEE

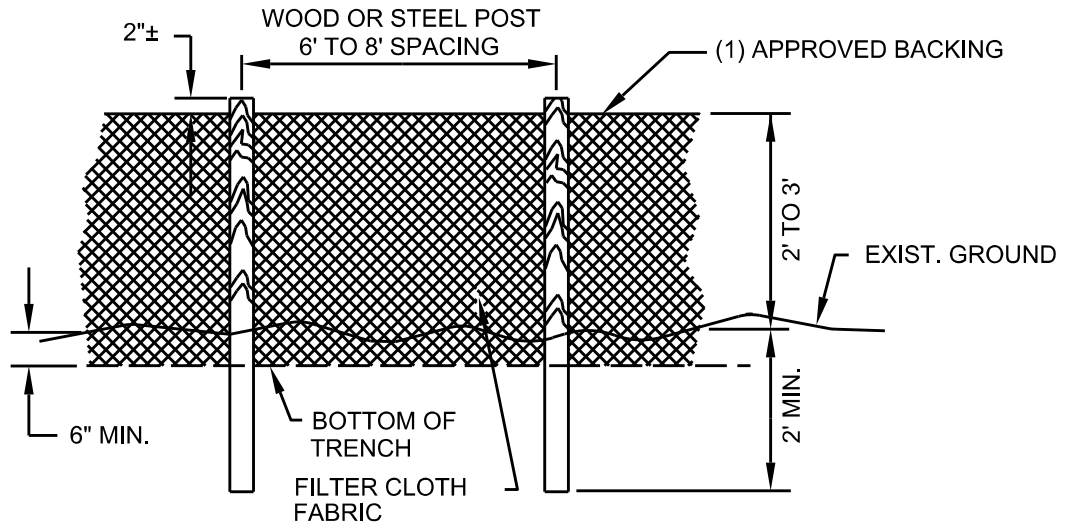

ELEVATION

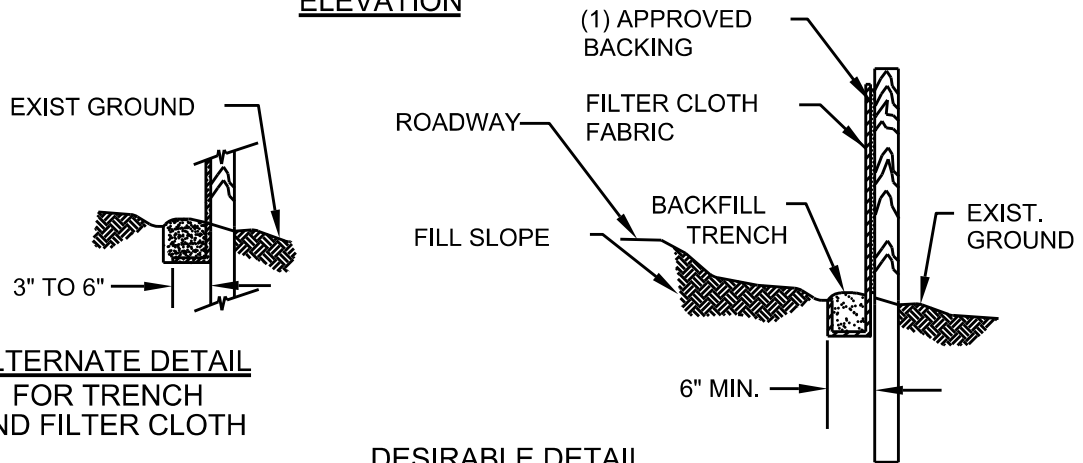

ALTERNATE DETAIL FOR TRENCH AND FILTER CLOTH

DESIRABLE DETAIL FOR TRENCH AND SECTION VIEW

FILTER CLOTH

NOTES:

- 1) BUILT-IN REINFORCED STRUCTURE, AS RECOMMENDED BY THE MANUFACTURER TO SUPPORT THE FILTER CLOTH.
- 2) FILTER CLOTH SHALL MEET THE REQUIREMENTS OF SECTION 209 OF STANDARD SPECIFICATIONS. (TDOT)
- 3) A PRE ASSEMBLED SILT FENCE MEETING THE REQUIREMENT OF THIS DRAWING IS ACCEPTABLE IN LIEU OF A FIELD CONSTRUCTED SILT FENCE.

DATE: 07/2022

NOT TO SCALE

TEMPORARY SILT FENCE

STANDARD DETAIL

TOWN OF CHAPEL HILL
CHAPEL HILL, TENNESSEE

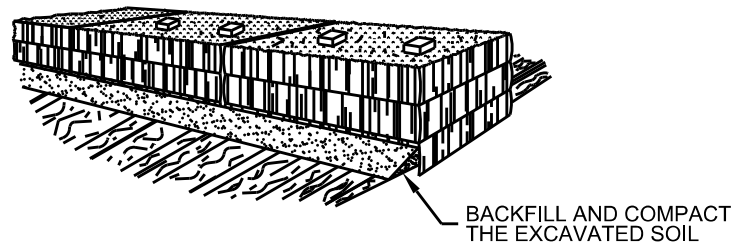
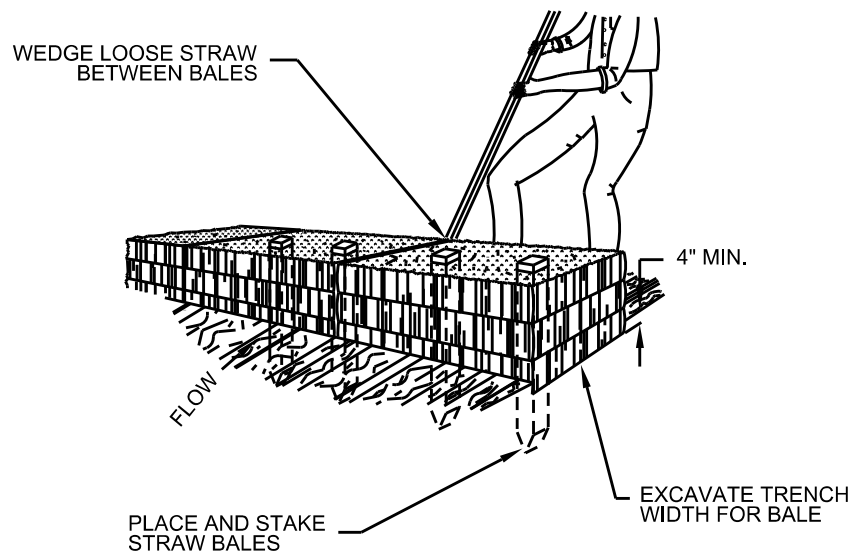

STRAW BALE BARRIER

DATE: 07/2022

NOT TO SCALE

STRAW BALE BARRIER

STANDARD DETAIL

TOWN OF CHAPEL HILL
CHAPEL HILL, TENNESSEE

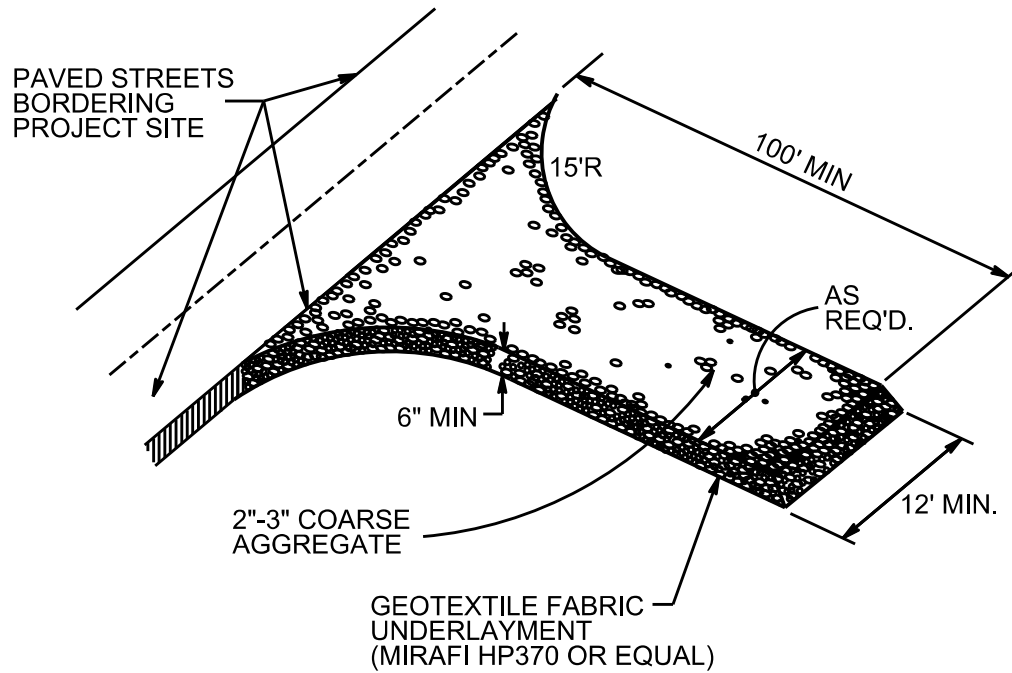

NOTE:
 GRAVEL PAD IS REQUIRED TO PROVIDE BUFFER AREA WHERE VEHICLES CAN DROP THEIR MUD AND SEDIMENT TO AVOID TRANSPORTING IT ONTO PAVED STREETS, TO CONTROL EROSION FROM SURFACE RUNOFF, AND TO HELP CONTROL DUST.

DATE: 07/2022

NOT TO SCALE

TEMPORARY CONSTRUCTION ENTRANCE

STANDARD DETAIL

TOWN OF CHAPEL HILL
 CHAPEL HILL, TENNESSEE

9.03 M

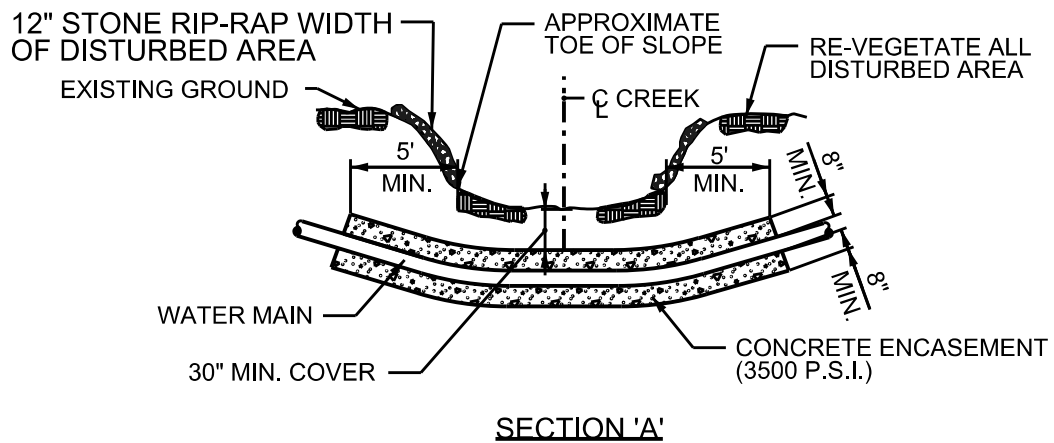
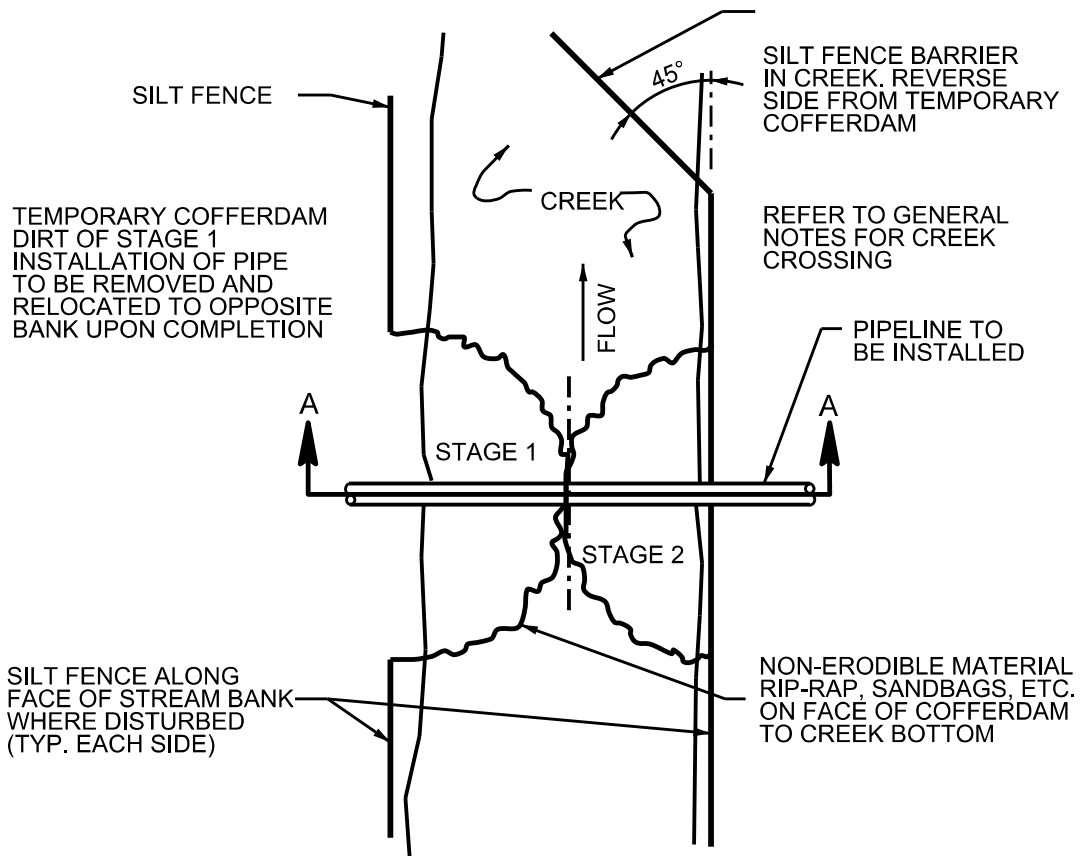

DATE: 07/2022

NOT TO SCALE

CREEK CROSSING

STANDARD DETAIL

TOWN OF CHAPEL HILL
 CHAPEL HILL, TENNESSEE

NOTES:

1. ALL SURFACE WATER FLOWING TOWARD THE EXCAVATION OR FILL WORK SHALL BE DIVERTED, PIPED OR FLUMED TO THE DOWNSTREAM SIDE OF THE WORK. THIS CAN BE ACCOMPLISHED THROUGH UTILIZATION OF COFFERDAMS OR CONSTRUCTED BERMS IN CONJUNCTION WITH A PIPE OR FLUME. COFFERDAMS MUST BE CONSTRUCTED OF SANDBAGS, CLEAN ROCK, STEEL SHEETING OR OTHER NON-ERODABLE MATERIAL.
2. TEMPORARY EROSION CONTROL MEASURES MUST BE IN PLACE BEFORE EARTHMOVING OPERATIONS BEGIN, MAINTAINING THROUGHOUT THE CONSTRUCTION PERIOD AND REPAIRED, IF NECESSARY AFTER RAINFALL. STRAW OR HAY BALES AND/OR SILT FENCE MUST BE INSTALLED ALONG THE BASE OF ALL FILLS AND CUTS, ON THE DOWNHILL SIDE OF STOCKPILED SOIL, AND ALONG STREAM BANKS IN CLEARED AREAS TO PREVENT EROSION INTO STREAMS. THEY MUST BE INSTALLED PARALLEL TO THE STREAM CHANNEL, ENTRENCHED AND STAKED, AND EXTEND THE WIDTH OF THE AREA TO BE CLEARED. THE BALES AND/OR SILT FENCE MAY BE REMOVED AT THE BEGINNING OF THE WORKDAY, BUT MUST BE REPLACED AT THE END OF THE WORKDAY.
3. BACKFILL ACTIVITIES MUST BE ACCOMPLISHED IN A MANNER WHICH STABILIZES THE STREAM BED AND BANKS TO PREVENT EROSION. BACKFILL MATERIALS SHALL CONSIST OF SUITABLE MATERIALS FREE OF CONTAMINANTS. ALL CONTOURS MUST BE RETURNED TO PRE-POST CONDITIONS. THE COMPLETED WORK MAY NOT DISRUPT OR IMPOUND STREAM FLOW.
4. SLURRY WATER PUMPED FROM WORK AREAS AND EXCAVATIONS MUST BE HELD IN SETTLING BASINS OR TREATED BY FILTRATION PRIOR TO INITIAL DISCHARGE INTO SURFACE WATERS. WATER MUST BE HELD IN SEDIMENT BASINS UNTIL AT LEAST AS CLEAR AS THE RECEIVING WATERS. SEDIMENTATION BASINS SHALL NOT BE LOCATED CLOSER THAN 20 FEET FROM THE TOP BANK OF A STREAM. SEDIMENT BASINS AND TRAPS SHALL BE PROPERLY DESIGNED ACCORDING TO THE SIZE OF THE DRAINAGE AREAS OR VOLUME OF WATER TO BE TREATED.
5. CHECKDAMS SHALL BE UTILIZED WHERE RUNOFF IS CONCENTRATED. CLEAN ROCK, LOG, SANDBAG OR STRAW BALE CHECKDAMS SHALL BE PROPERLY CONSTRUCTED TO DETAIN RUNOFF AND TRAP SEDIMENT.
6. CLEARING, GRUBBING AND OTHER DISTURBANCE TO RIPARIAN VEGETATION SHALL BE LIMITED TO THE MINIMUM NECESSARY FOR SLOPE CONSTRUCTION AND EQUIPMENT OPERATIONS. UNNECESSARY VEGETATION REMOVAL IS PROHIBITED. ALL DISTURBED AREAS SHALL BE PROPERLY STABILIZED AS SOON AS PRACTICABLE.
7. STREAMS SHALL NOT BE USED AS TRANSPORTATION ROUTES FOR HEAVY EQUIPMENT. CROSSINGS MUST BE LIMITED TO ONE POINT AND EROSION CONTROL MEASURES MUST BE UTILIZED WHERE THE STREAM BANKS ARE DISTURBED. WHERE THE STREAMBED IS NOT COMPOSED OF ROCK, A PAD OF CLEAN ROCK MUST BE USED AT THE CROSSING POINT. ALL TEMPORARY FILL MUST BE COMPLETELY REMOVED AFTER THE WORK IS COMPLETED.
8. CONSTRUCTION DEBRIS MUST BE KEPT FROM ENTERING THE STREAM CHANNEL.
9. ALL SPILLS OF PETROLEUM PRODUCTS OR OTHER POLLUTANTS MUST BE REPORTED TO THE APPROPRIATE EMERGENCY MANAGEMENT AGENCY AND MEASURES SHALL BE TAKEN IMMEDIATELY TO PREVENT THE POLLUTION OF WATERS OF THE STATE, INCLUDING GROUNDWATER.
10. UPON ACHIEVEMENT OF FINAL GRADE, THE DISTURBED STREAMBANK SHALL BE STABILIZED WITH RIPRAP (MIN. SIZE = 12"). ALL OTHER DISTURBED SOILS MUST BE STABILIZED AND RE-VEGETATED WITHIN 30 DAYS BY SODDING OR SEEDING AND MULCHING. SEED TO BE UTILIZED SHALL INCLUDE COMBINATION OF ANNUAL GRAINS AND GRASSES, LEGUMES, AND PERENNIAL GRASSES. LIME AND FERTILIZER SHALL BE APPLIED AS NEEDED TO ACHIEVE A VEGETATIVE COLOR.
11. UPON COMPLETION OF CONSTRUCTION, THE STREAM SHALL BE RETURNED AS NEARLY AS POSSIBLE TO ITS ORIGINAL, NATURAL CONDITION.

DATE: 07/2022

NOT TO SCALE

GENERAL NOTES FOR CREEK CROSSING

STANDARD DETAIL

TOWN OF CHAPEL HILL
CHAPEL HILL, TENNESSEE

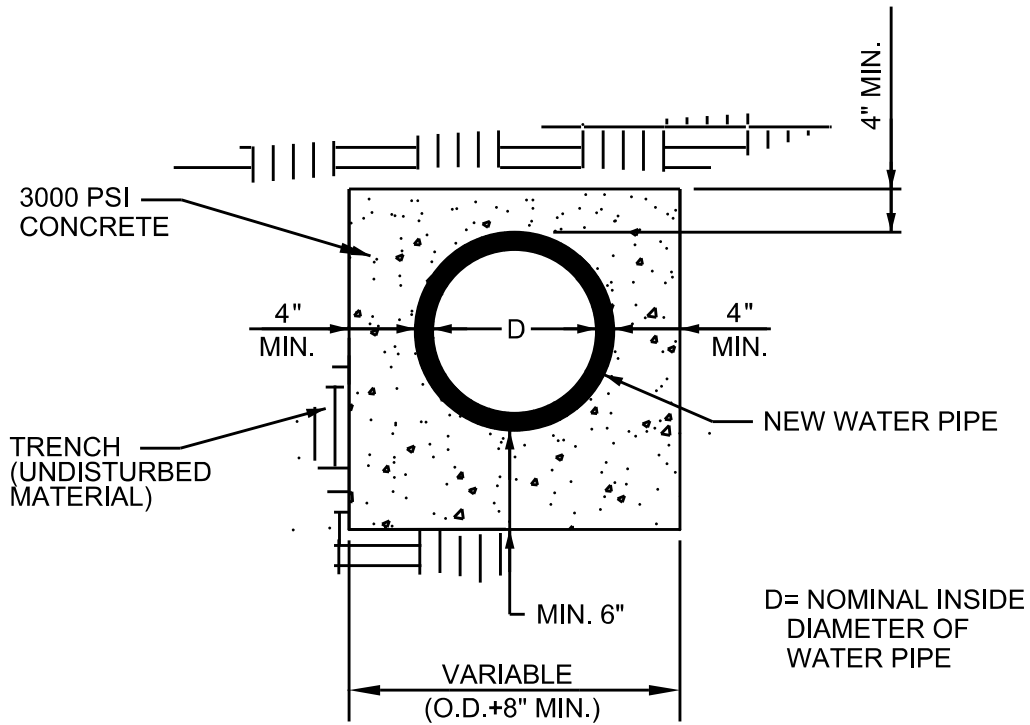

3000 PSI CONCRETE TO BE
POURED 16 HOURS BEFORE
BACKFILL IS PLACED AND IN
SUCH A MANNER AS TO
PREVENT PIPE FROM FLOATING.

DATE: 07/2022

NOT TO SCALE

CONCRETE PROTECTION FOR UTILITY LINES

STANDARD DETAIL

TOWN OF CHAPEL HILL
CHAPEL HILL, TENNESSEE

9.06 M

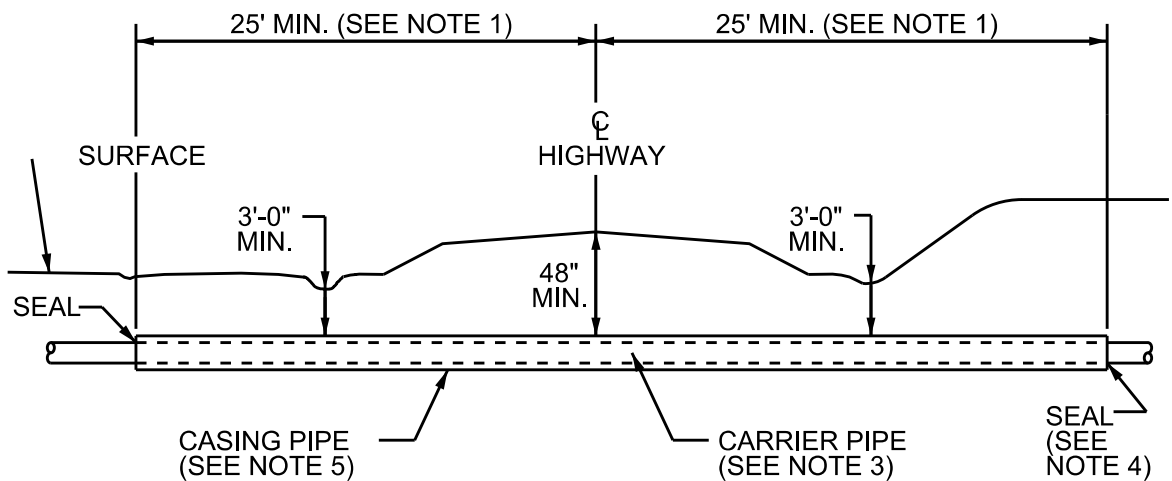

NOTES:

1. CASING SHALL EXTEND TO THE GREATER OF THE FOLLOWING DISTANCES:
 - A. 2' BEYOND TOE OF SLOPE
 - B. 5' BEYOND CENTERLINE OF DITCH
 - C. MIN. OF 25' WHEN CASING IS SEALED AT BOTH ENDS
2. BORED CROSSINGS SHALL BE PERMITTED AND INSTALLED TO MEET THE REQUIREMENTS OF TENNESSEE DEPARTMENT OF TRANSPORTATION AND/OR FAYETTE COUNTY HIGHWAY DEPARTMENT.
3. CARRIER PIPE SHALL BE DUCTILE IRON PIPE AS REQUIRED BY THE TOWN. CARRIER PIPE SHALL BE CENTERED IN THE CASING PIPE. CARRIER PIPE SHALL BE INSTALLED USING CASING SPACERS. SPACERS SHALL BE PLACED AT PIPE JOINT MIDPOINT AND 1' FROM EACH END OF PIPE JOINT.
4. ENDS OF CASING PIPE SHALL BE SEALED UTILIZING SYNTHETIC RUBBER SEALS WITH STAINLESS STEEL BINDING STRAPS.
5. REFER TO SPECIFICATION FOR CASING PIPE THICKNESS AND DIAMETER.

DATE: 07/2022

NOT TO SCALE

BORE AND JACK HIGHWAYS

STANDARD DETAIL

TOWN OF CHAPEL HILL
CHAPEL HILL, TENNESSEE

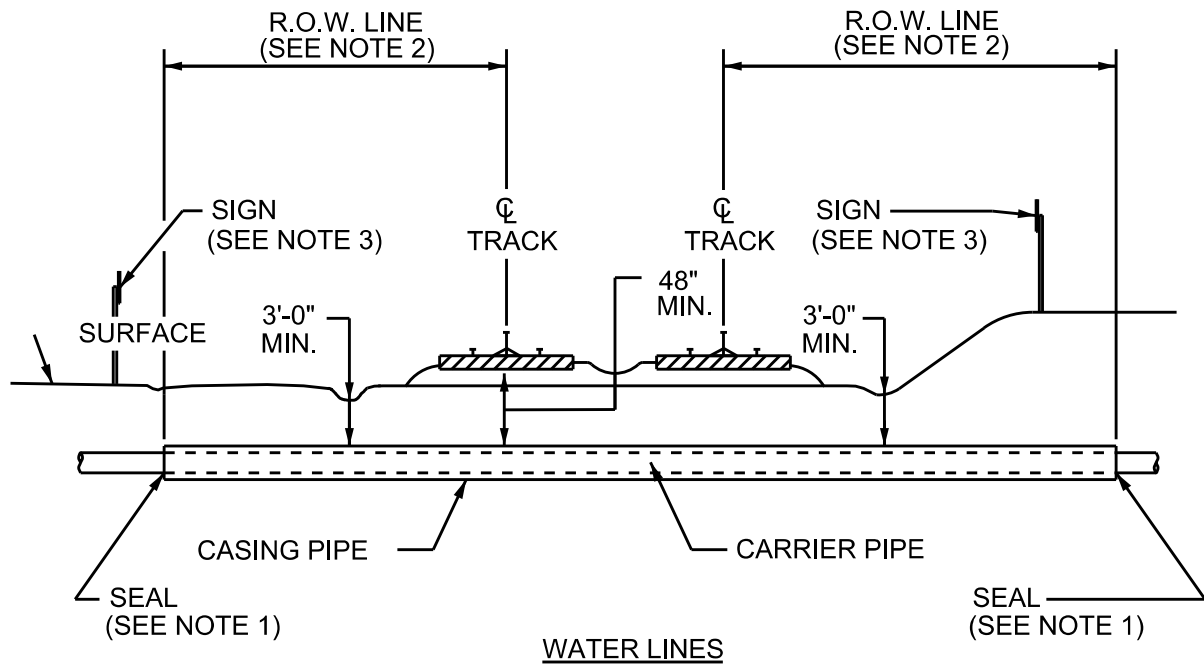

NOTES:

1. ENDS OF CASING PIPE SHALL BE SEALED UTILIZING SYNTHETIC RUBBER SEALS WITH STAINLESS STEEL BINDING STRAPS.
2. CASING SHALL EXTEND TO THE R.O.W. LINE UNLESS R.O.W. LINE FALLS WITHIN SLOPE OR DITCH. THEN CASING SHALL EXTEND 2' BEYOND TOE OF SLOPE OR 3' BEYOND DITCH LINE.
3. SIGN TO INDICATE LOCATION OF PIPE LINE AT R.O.W. LINE, KIND OWNERSHIP.
4. REFER TO SPECIFICATION FOR CASING PIPE THICKNESS AND DIAMETER.

DATE: 07/2022

NOT TO SCALE

BORE AND JACK FOR RAILROADS

STANDARD DETAIL

TOWN OF CHAPEL HILL
CHAPEL HILL, TENNESSEE

9.08 M

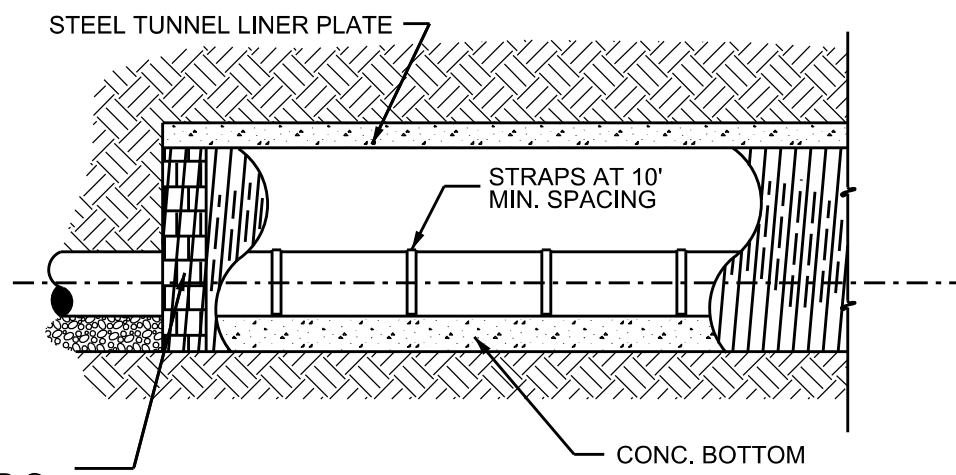
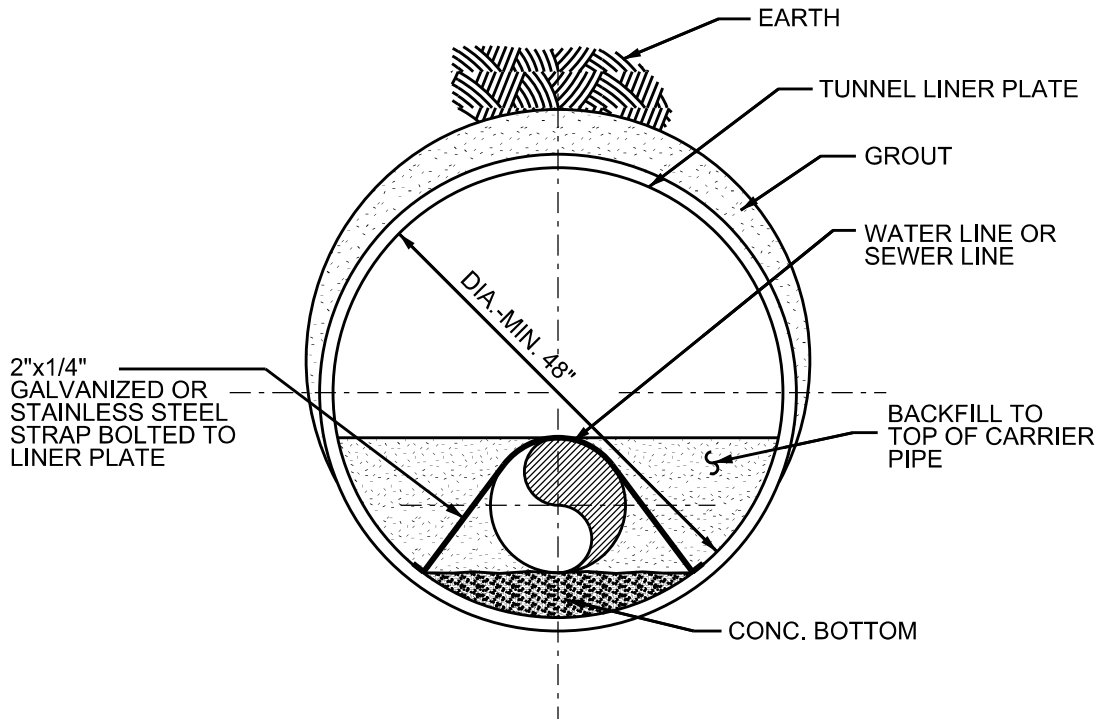

DATE: 07/2022

NOT TO SCALE

TYPICAL TUNNEL LINER INSTALLATION

STANDARD DETAIL

TOWN OF CHAPEL HILL
CHAPEL HILL, TENNESSEE

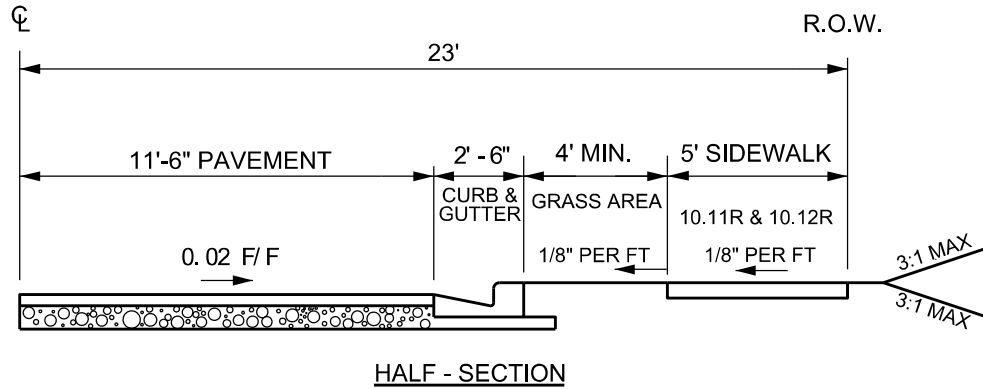

GENERAL NOTES

CONSTRUCTION SHALL CONFORM TO THE
TOWN OF CHAPEL HILL TECHNICAL
SPECIFICATIONS, LATEST REVISION

PAVEMENT SCHEDULE

- ① 1-1/2" ASPHALTIC CONCRETE SURFACE (411D)
- ② TACK COAT (SS-1)
- ③ 2" BITUMINOUS BINDER (B-M2)
- ④ PRIME COAT (RS-2)
- ⑤ 8" STONE (GRADING D PUG MILL MIX)

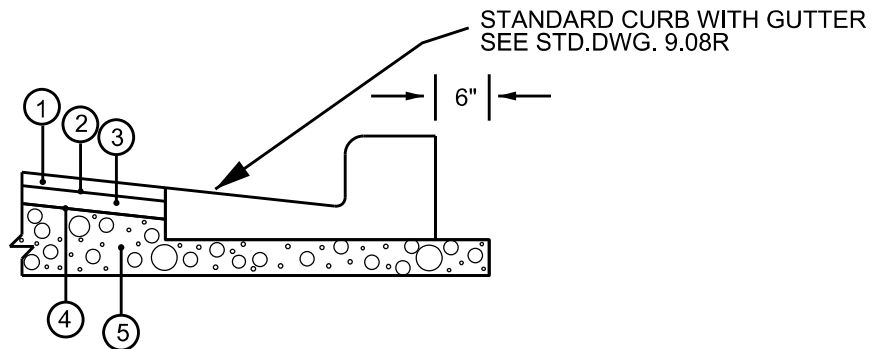

DATE: 07/2022

NOT TO SCALE

**RESIDENTIAL - LOW DENSITY
MINOR LOCAL STREET (46' R.O.W.)**

STANDARD DETAIL

TOWN OF CHAPEL HILL
CHAPEL HILL, TENNESSEE

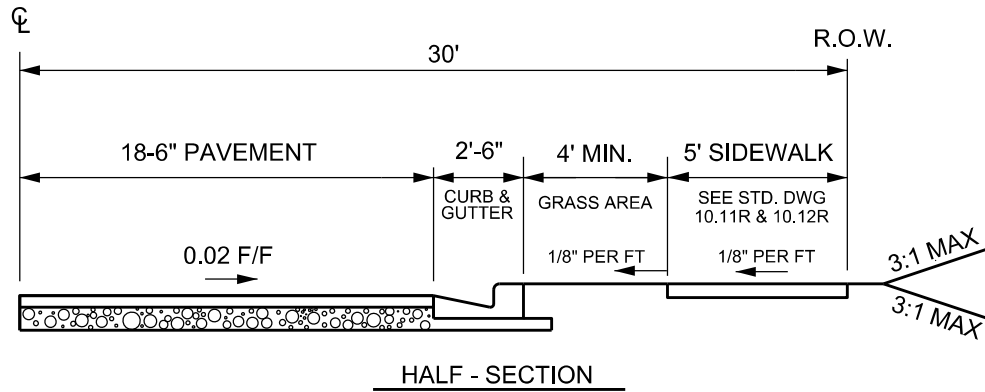

GENERAL NOTES

CONSTRUCTION SHALL CONFORM TO THE TOWN OF CHAPEL HILL TECHNICAL SPECIFICATIONS, LATEST REVISION

PAVEMENT SCHEDULE

- ① 1-1/2" ASPHALTIC CONCRETE SURFACE (411D)
- ② TACK COAT (SS-1)
- ③ 2" BITUMINOUS BINDER (B-MS)
- ④ TACK COAT (SS-1)
- ⑤ 4" BITUMINOUS BASE (307A)
- ⑥ PRIME COAT (RS-2)
- ⑦ 10" STONE (GRADING D PUG MILL MIX)

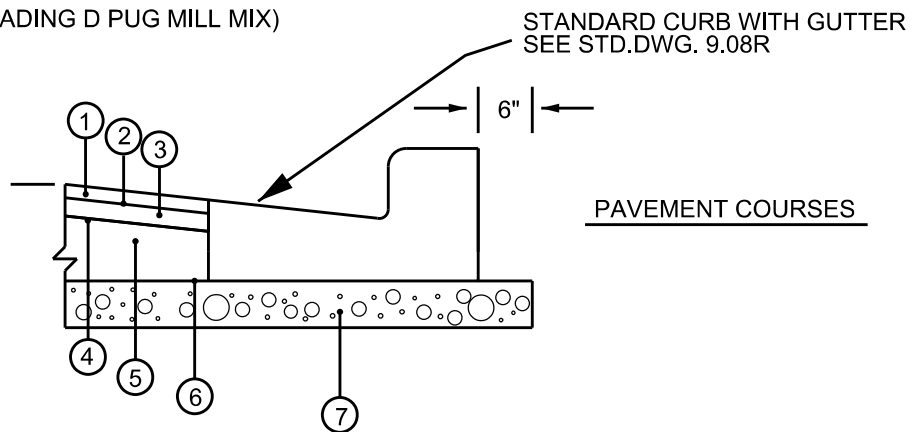

DATE: 07/2022

NOT TO SCALE

**RESIDENTIAL - MEDIUM DENSITY COLLECTOR
OR HIGH DENSITY LOCAL STREET (60' R.O.W.)**

STANDARD DETAIL

TOWN OF CHAPEL HILL
CHAPEL HILL, TENNESSEE

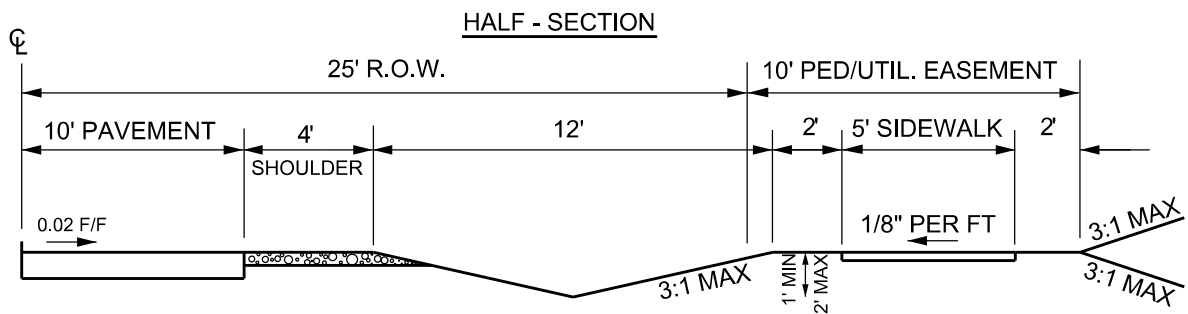

GENERAL NOTES

- ① CONSTRUCTION SHALL CONFORM TO THE TOWN OF CHAPEL HILL TECHNICAL SPECIFICATIONS, LATEST REVISION.
- ② SIDEWALK GRADE SHALL MATCH ROAD GRADE AT CENTERLINE.
- ③ IN THE EVENT OF ANY CONFLICT, DISCREPANCY, OR INCONSISTENCY AMONG THE PLANS AND THESE STANDARD DETAILS, THE REQUIREMENTS OF THE STANDARD DETAILS SHALL GOVERN.

PAVEMENT SCHEDULE

- ① 1-1/2" ASPHALTIC CONCRETE SURFACE (411D)
- ② TACK COAT (SS-1)
- ③ 2" BITUMINOUS BINDER (B-M2)
- ④ PRIME COAT (RS-2)
- ⑤ 8" STONE (GRADING D PUG MILL MIX)
- ⑥ DOUBLE BITUMINOUS SURFACE TREATMENT
- ⑦ 7" STONE (GRADING D PUG MILL MIX)

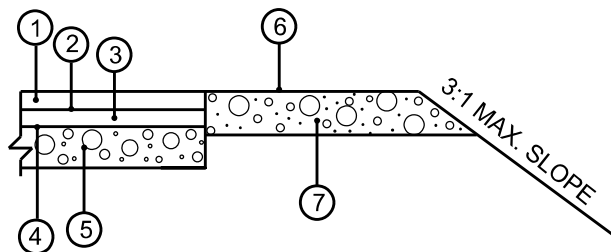

PAVEMENT & SHOULDER COURSES

DATE: 07/2022

NOT TO SCALE

**NON-CURB AND GUTTER
ROAD SECTION**

STANDARD DETAIL

TOWN OF CHAPEL HILL
CHAPEL HILL, TENNESSEE

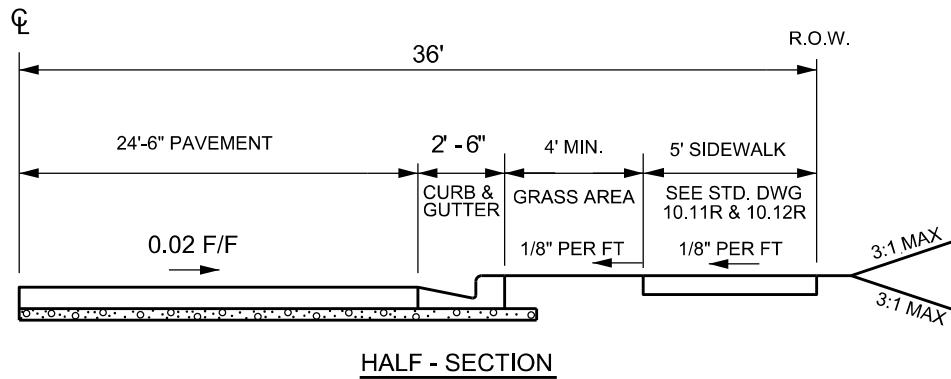

GENERAL NOTES

CONSTRUCTION SHALL CONFORM TO THE TOWN OF CHAPEL HILL TECHNICAL SPECIFICATIONS, LATEST REVISION

PAVEMENT SCHEDULE

- ① 1-1/2" ASPHALTIC CONCRETE SURFACE (411D)
- ② TACK COAT (SS-1)
- ③ 2" BITUMINOUS BINDER (B-M2)
- ④ TACK COAT (SS-1)
- ⑤ 4" BITUMINOUS BASE (307A)
- ⑥ PRIME COAT (RS-2)
- ⑦ 10" STONE (GRADING D PUG MILL MIX)

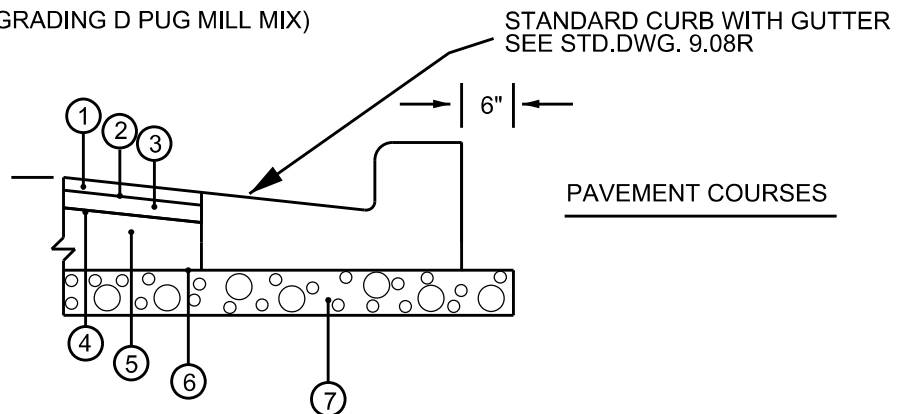

DATE: 07/2022

NOT TO SCALE

**NON-RESIDENTIAL COLLECTOR STREET
(72' R.O.W.)**

STANDARD DETAIL

TOWN OF CHAPEL HILL
CHAPEL HILL, TENNESSEE

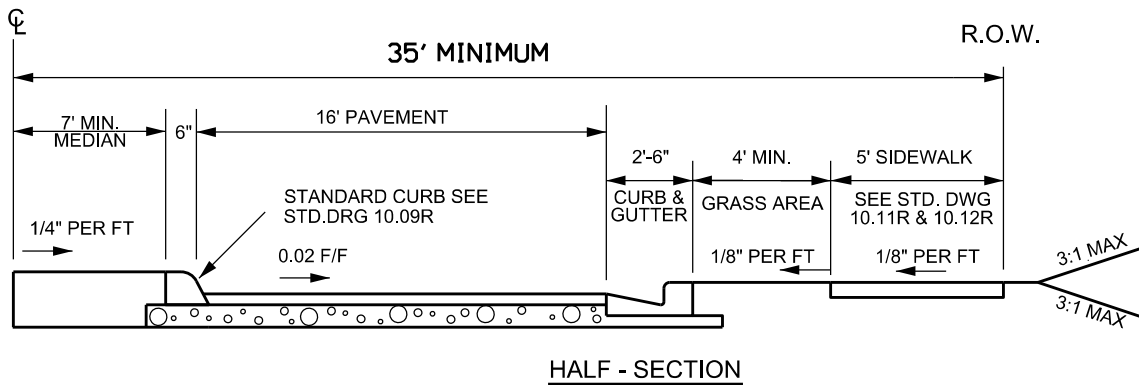

GENERAL NOTES

CONSTRUCTION SHALL CONFORM TO THE
TOWN OF CHAPEL HILL TECHNICAL
SPECIFICATIONS, LATEST REVISION

PAVEMENT SCHEDULE

- ① 1-1/2" ASPHALTIC CONCRETE SURFACE (411D)
- ② TACK COAT (SS-1)
- ③ 2" BITUMINOUS BINDER (B-M2)
- ④ PRIME COAT (RS-2)
- ⑤ 8" STONE (GRADING D PUG MILL MIX)

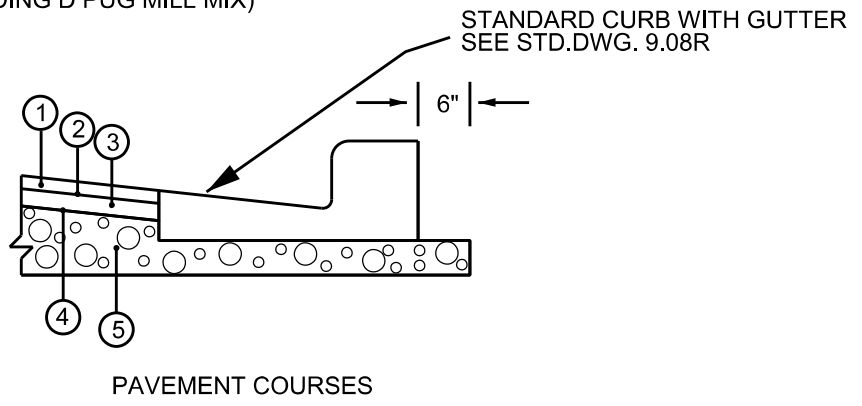

DATE: 07/2022

NOT TO SCALE

**RESIDENTIAL DIVIDED STREET
(70' MINIMUM R.O.W.)**

STANDARD DETAIL

TOWN OF CHAPEL HILL
CHAPEL HILL, TENNESSEE

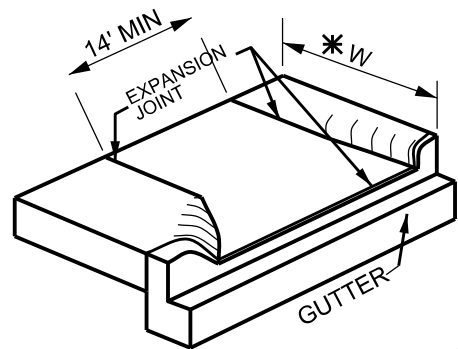

* VARIES WITH WIDTH OF SIDEWALK

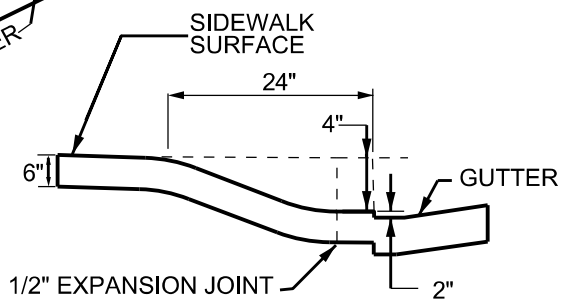

CONCRETE DRIVEWAY - RESIDENTIAL ENTRANCE

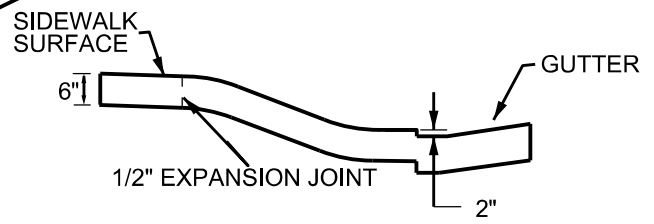
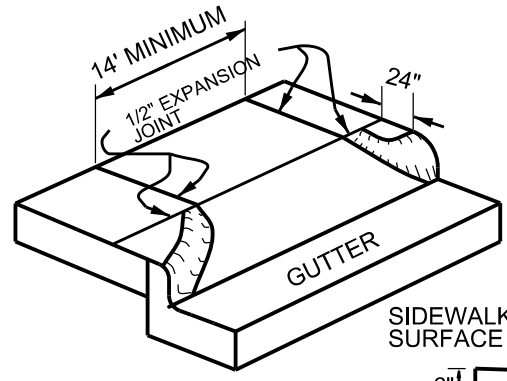

CONCRETE DRIVEWAY - RESIDENTIAL ENTRANCE ACROSS SIDEWALK WITH GRASS PLOT

DATE: 07/2022

NOT TO SCALE

CONCRETE DRIVE RAMP (RESIDENTIAL)

STANDARD DETAIL

TOWN OF CHAPEL HILL
CHAPEL HILL, TENNESSEE

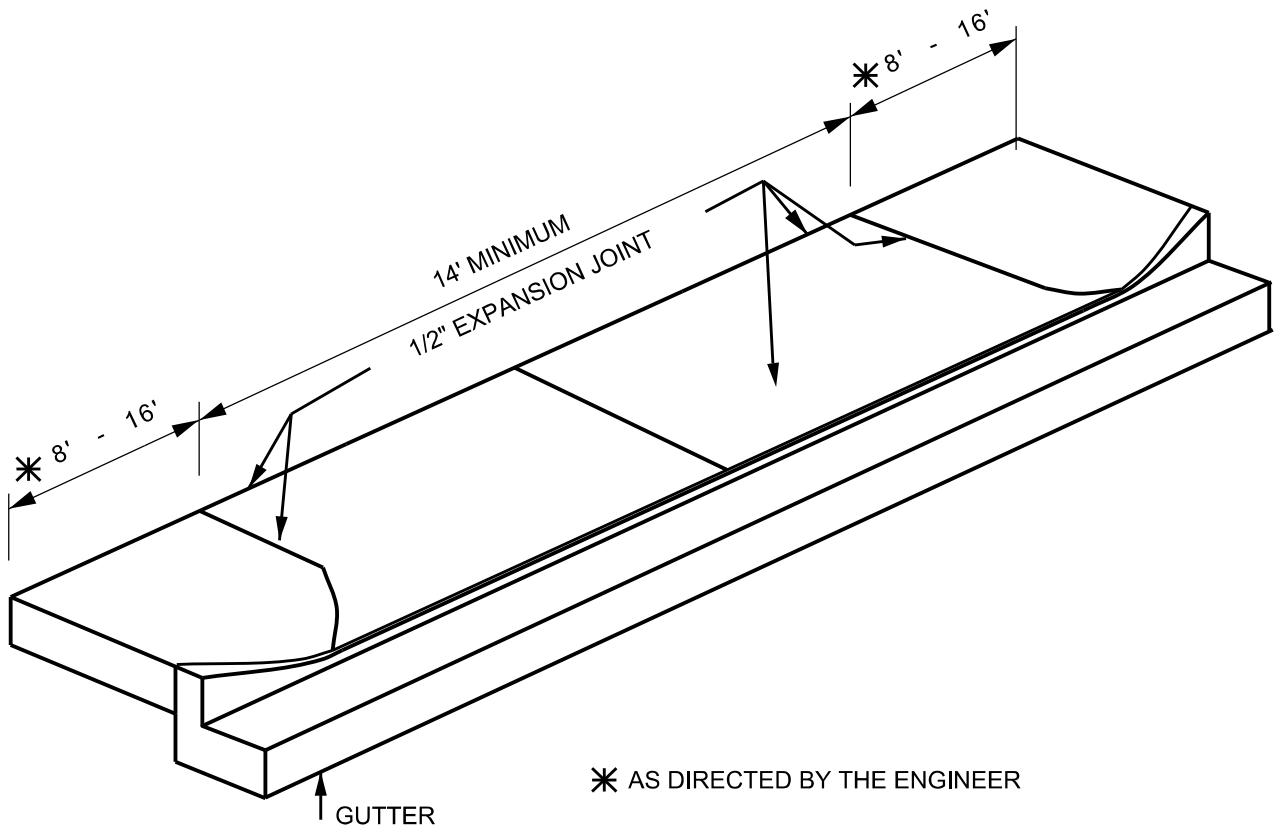

* AS DIRECTED BY THE ENGINEER

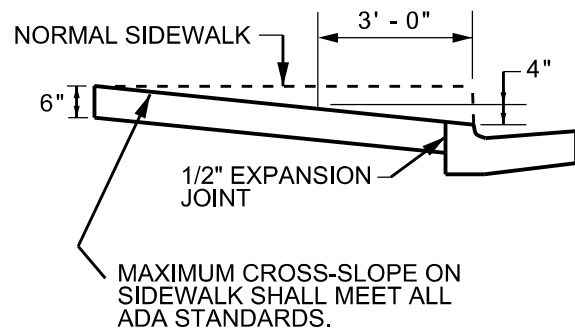

CONCRETE DRIVEWAY -
BUSINESS ENTRANCE

DATE: 07/2022

NOT TO SCALE

CONCRETE DRIVE RAMP (COMMERCIAL)

STANDARD DETAIL

TOWN OF CHAPEL HILL
CHAPEL HILL, TENNESSEE

9.07 R

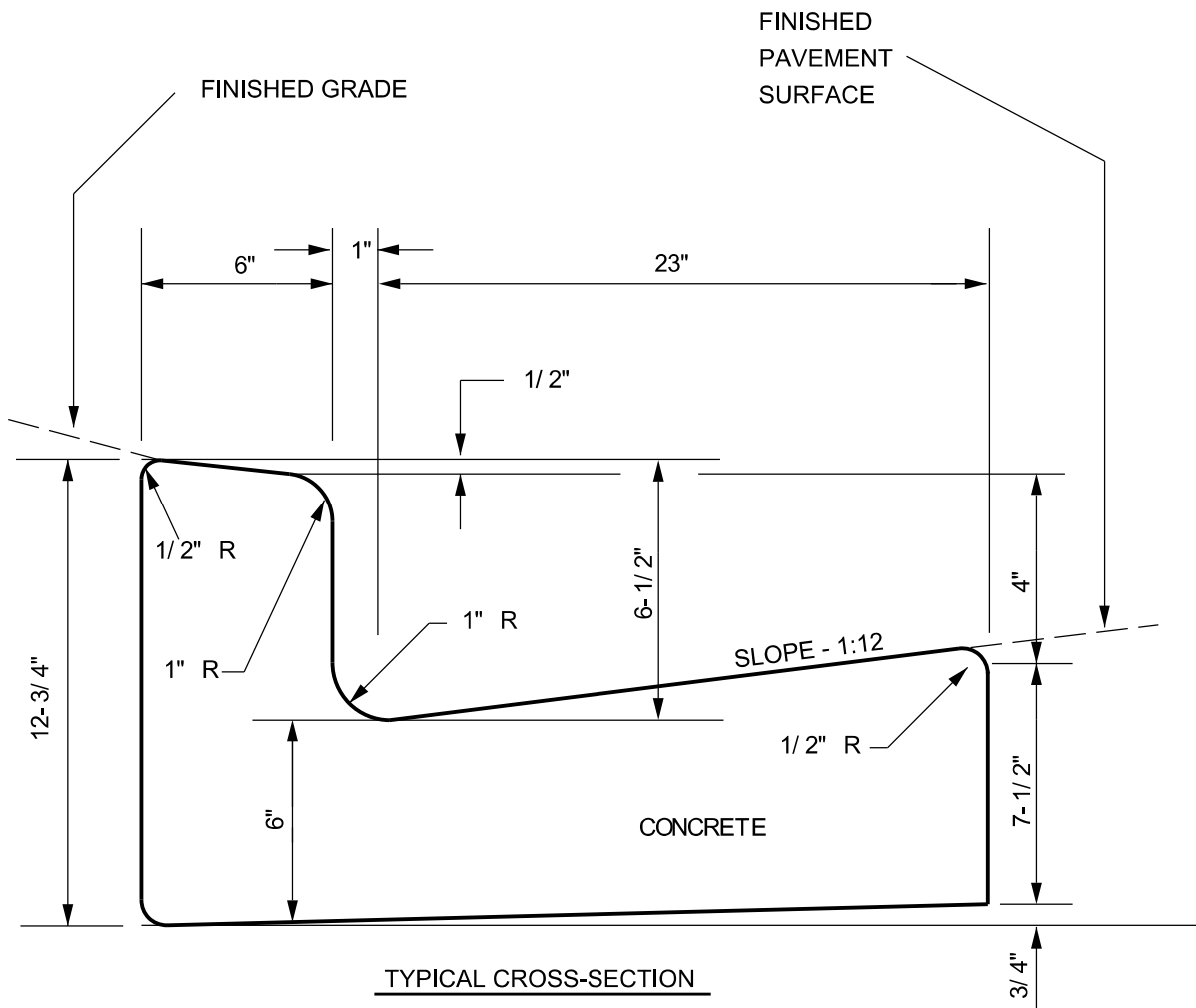

GENERAL NOTES

- ① EXPANSION JOINTS TO BE SPACED A MAXIMUM OF 100 FEET APART OR AS DIRECTED BY THE ENGINEER.
- ② EXPANSION JOINTS WILL ALSO BE REQUIRED AT TANGENT POINTS, RAMPS, AND INLETS.
- ③ CONTRACTION JOINTS ARE TO BE CUT INTO CURB AND GUTTER EVERY 10 FEET TO A DEPTH OF D/4, WHERE D EQUALS THE THICKNESS OF THE SECTION.

DATE: 07/2022

NOT TO SCALE

STANDARD CURB WITH GUTTER

STANDARD DETAIL

TOWN OF CHAPEL HILL
CHAPEL HILL, TENNESSEE

9.08 R

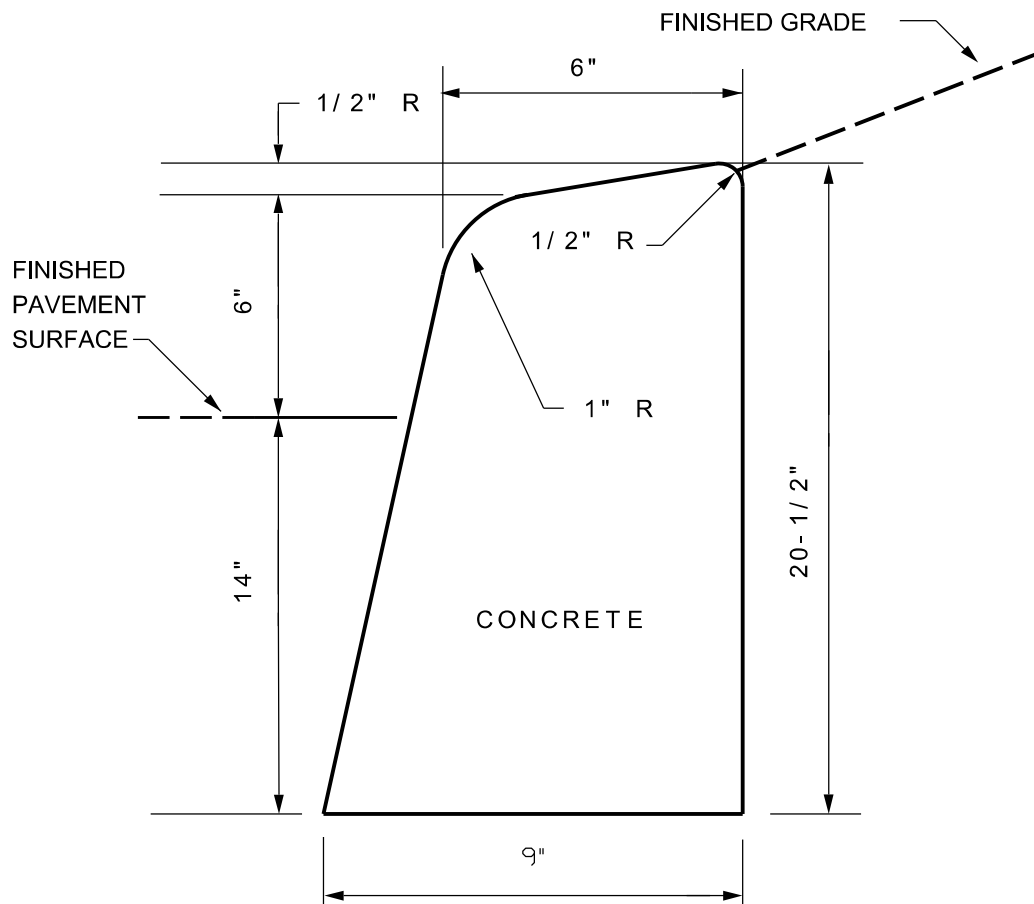

TYPICAL CROSS-SECTION

GENERAL NOTES

- ① EXPANSION JOINTS TO BE SPACED A MAXIMUM OF 100 FEET APART OR AS DIRECTED BY THE ENGINEER.
- ② EXPANSION JOINTS WILL ALSO BE REQUIRED AT TANGENT POINTS, RAMPS, AND INLETS.
- ③ CONTRACTION JOINTS ARE TO BE CUT INTO CURB EVERY 10 FEET TO A DEPTH OF D/4, WHERE D EQUALS THE THICKNESS OF THE SECTION.

DATE: 07/2022

NOT TO SCALE

CONCRETE POST CURB

STANDARD DETAIL

TOWN OF CHAPEL HILL
CHAPEL HILL, TENNESSEE

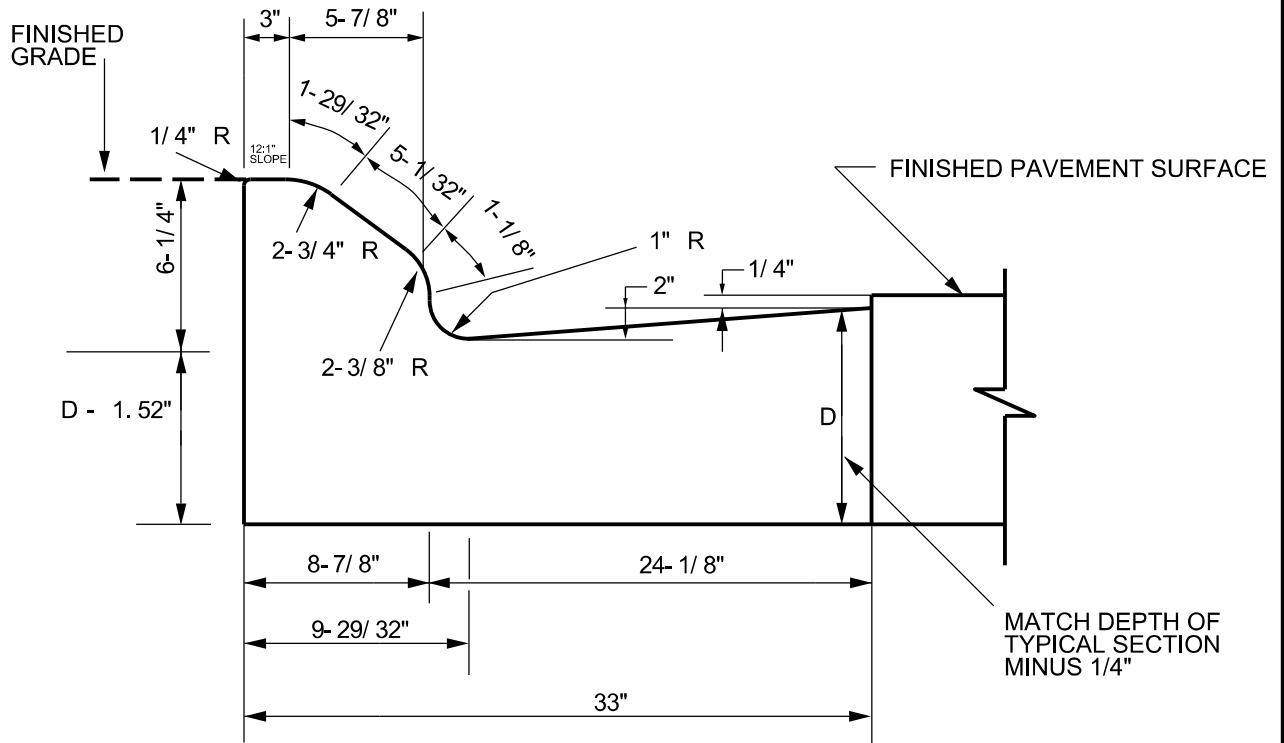

GENERAL NOTES

- ① EXPANSION JOINTS TO BE SPACED A MAXIMUM OF 100 FEET APART OR AS DIRECTED BY THE ENGINEER.
- ② EXPANSION JOINTS WILL ALSO BE REQUIRED AT TANGENT POINTS, RAMPS, AND INLETS.
- ③ CONTRACTION JOINTS ARE TO BE CUT INTO CURB AND GUTTER EVERY 10 FEET TO A DEPTH OF D/4, WHERE D EQUALS THE THICKNESS OF THE SECTION.

DATE: 07/2022

NOT TO SCALE

MOUNTABLE CURB WITH GUTTER

STANDARD DETAIL

TOWN OF CHAPEL HILL
CHAPEL HILL, TENNESSEE

9.10 R

SEE STANDARD DRAWING
9.14R FOR EXPANSION
JOINT LOCATIONS

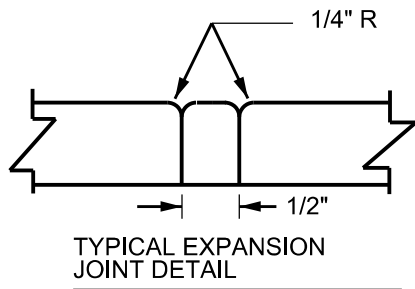
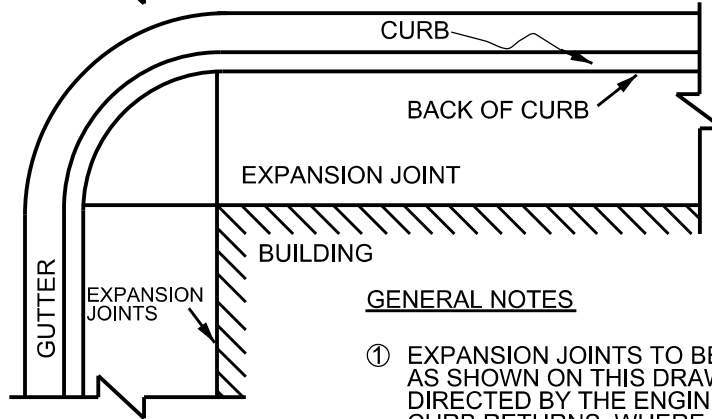
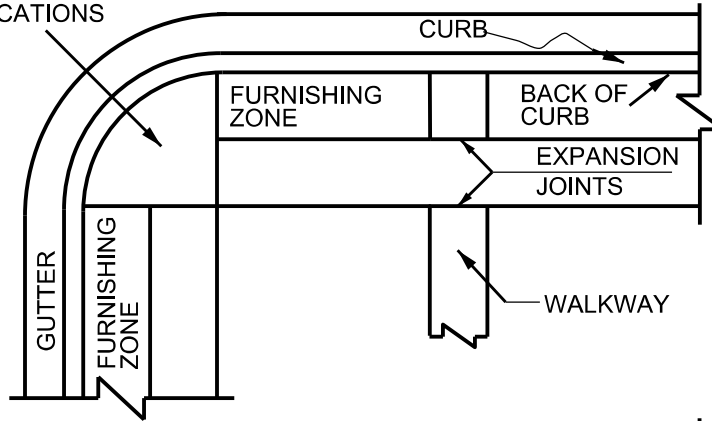

GENERAL NOTES

- ① EXPANSION JOINTS TO BE PLACED AS SHOWN ON THIS DRAWING OR AS DIRECTED BY THE ENGINEER, AT CURB RETURNS, WHERE BUILDINGS ARE ADJACENT TO SIDEWALKS, AND AT WALKWAYS
- ② ONE INCH EXPANSION JOINTS SHALL BE PLACED WHERE THE SIDEWALK IS IN CONTACT WITH BUILDINGS AND RETAINING WALLS. ALL OTHER LOCATIONS SHALL UTILIZE 1/2" JOINTS.

DATE: 07/2022

NOT TO SCALE

TYPICAL SIDEWALK DETAILS

STANDARD DETAIL

TOWN OF CHAPEL HILL
CHAPEL HILL, TENNESSEE

NOTE: EXPANSION JOINT TO BE SPACED 25' OR 30' APART DEPENDING ON TRANSVERSE JOINT MARKINGS OR AS DIRECTED BY THE ENGINEER TO MATCH EXISTING LAYOUT.

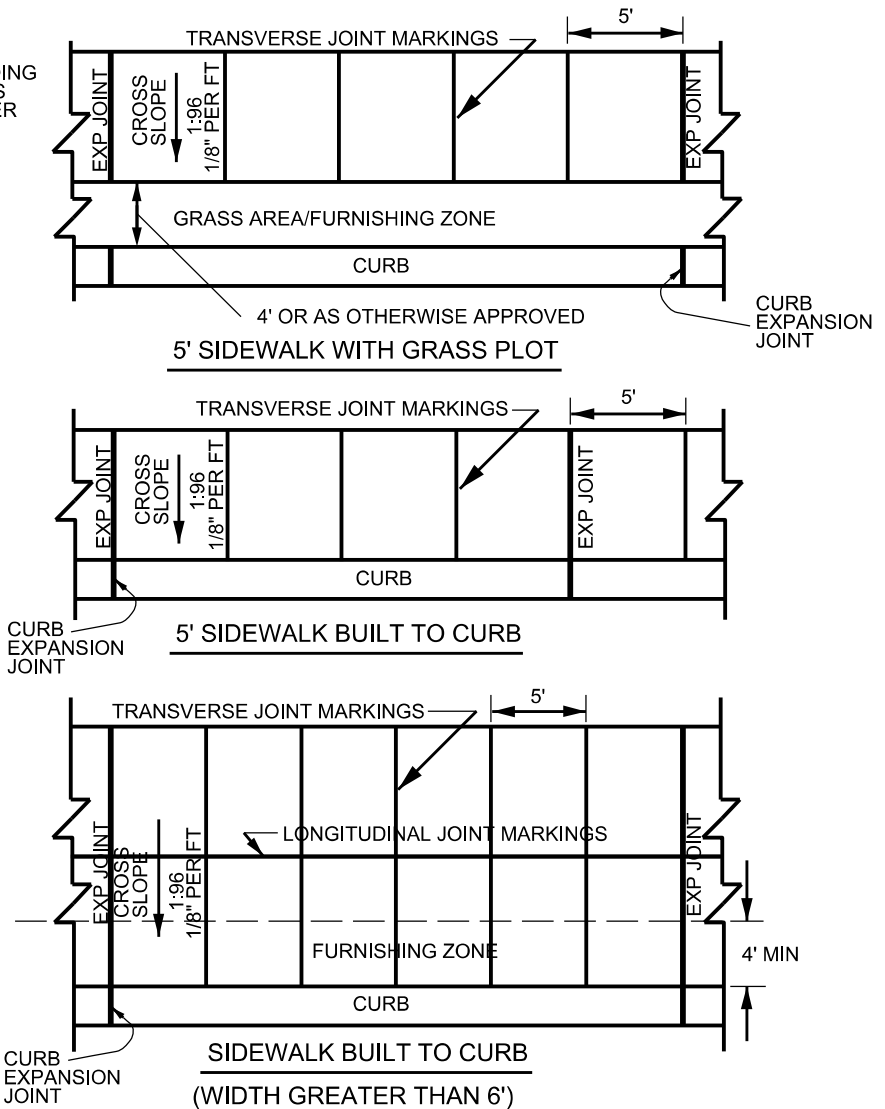

GENERAL NOTES

- ① SIDEWALKS SHALL BE A MINIMUM OF 4 INCHES IN THICKNESS.
- ② MAXIMUM CROSS SLOPE FOR SIDEWALKS SHALL NOT EXCEED 1:48 (VERTICAL:HORIZONTAL).
- ③ SIDEWALK SHALL BE CONSTRUCTED OF WHITE CONCRETE, BRICK, OR EXPOSED AGGREGATE TOWN OF CHAPEL HILL TECHNICAL SPECIFICATIONS.
- ④ COMPACTED STONE BASE, PUG MILL MIX, 4" THICK SHALL BE APPLIED TO SUB GRADE PRIOR TO INSTALLING SIDEWALK.
- ⑤ FURNISHING ZONE IS AN AREA FOR OBSTRUCTIONS IN THE SIDEWALK. EXAMPLES ARE OUTDOOR CAFES, POWER POLES, FIRE HYDRANTS, SIGNS, ETC.
- ⑥ IN THE EVENT OF ANY CONFLICT, DISCREPANCY, OR INCONSISTENCY AMONG THE PLANS AND THESE STANDARD DETAILS, THE REQUIREMENTS OF THE STANDARD DETAILS SHALL GOVERN.

DATE: 07/2022

NOT TO SCALE

TYPICAL SIDEWALK DETAILS

STANDARD DETAIL

TOWN OF CHAPEL HILL
CHAPEL HILL, TENNESSEE

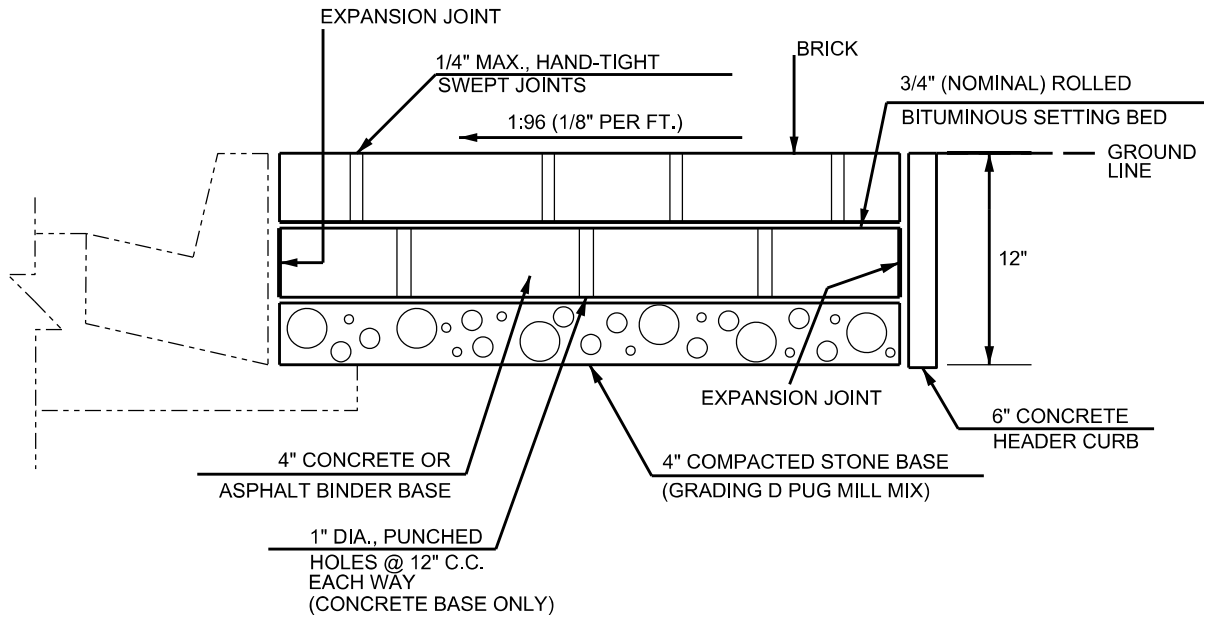

BRICK SIDEWALK COURSES

GENERAL NOTES

- ① THICKNESS OF THE FINISHED SETTING BED SHALL BE NO MORE THAN 1 INCH OR LESS THAN 1/2 INCH. THE SETTING BED SHALL BE ROLLED WITH A POWER ROLLER TO A NOMINAL DEPTH OF 3/4 INCH. THE THICKNESS SHALL BE ADJUSTED SO THAT WHEN THE BRICK IS PLACED THE TOP SURFACE OF THE BRICK SHALL BE AT THE REQUIRED FINISHED GRADE. HOWEVER, UNDER NO CIRCUMSTANCES SHALL THE SETTING BED EXCEED 1 INCH.
- ② HAND-TIGHT JOINTS SHALL BE FILLED BY SWEEPING A DRY MIXTURE OF ONE PART COLORED PORTLAND CEMENT TO MATCH COLOR OF BRICK AND THREE PARTS SAND UNTIL JOINTS ARE FLUSH WITH TOP SURFACE. FOG LIGHTLY WITH WATER. JOINTS MAY RECEDE UP TO 1/8 INCH.
- ③ A COATING OF 2 PERCENT NEOPRENE-MODIFIED ASPHALT SHALL BE APPLIED BY SQUEEGEEING OR TROWELING OVER THE TOP SURFACE OF THE BITUMINOUS SETTING BED SO AS TO PROVIDE A BOND UNDER THE BRICK.
- ④ PRIME CONCRETE BASE OR ASPHALT BINDER BASE WITH EMULSIFIED ASPHALT (RS-1 OR CRS-1) IF THERE IS TO BE VEHICULAR TRAFFIC OVER THE BRICK.
- ⑤ CROSS-SLOPE OF BRICK SIDEWALK SHALL NOT EXCEED 1:48 (VERTICAL:HORIZONTAL).

DATE: 07/2022

NOT TO SCALE

BRICK SIDEWALK WITH CONCRETE BASE

STANDARD DETAIL

TOWN OF CHAPEL HILL
CHAPEL HILL, TENNESSEE

PLAN VIEW

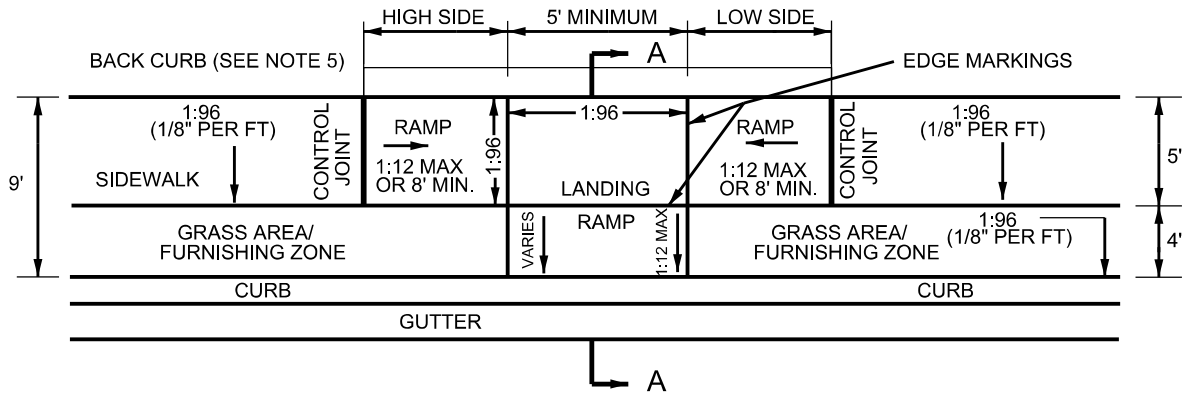

LONGITUDINAL STREET GRADE

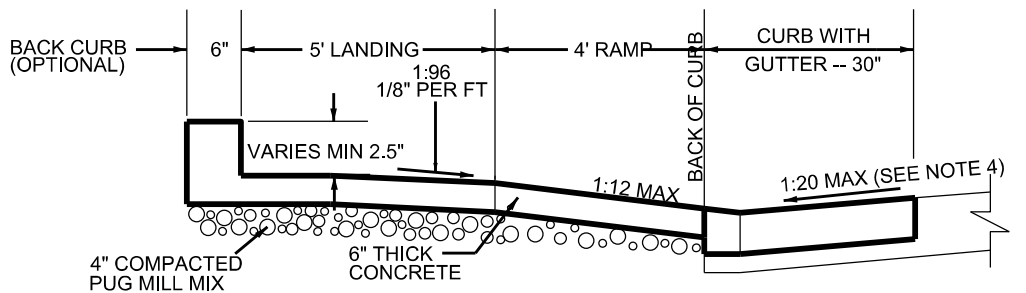

SECTION A - A

GENERAL NOTES

1. RAMP SHALL BE FLUSH WITH THE GUTTER OR EDGE OF PAVEMENT.
2. CROSS-SLOPE OF LANDING AND OF SIDEWALK SHALL NOT EXCEED 1:48 (VERTICAL:HORIZONTAL).
3. SURFACE TEXTURE OF THE CURB RAMP SHALL BE STABLE, FIRM, AND SLIP-RESISTANT. THE SURFACE SHALL BE COARSE BROOMED "WHITE" CONCRETE FINISH TRANSVERSE TO THE SLOPE OF THE RAMP.
4. THE NORMAL GUTTER SLOPE OF 1:12 (VERTICAL:HORIZONTAL) SHALL BE REDUCED TO 1:20 (VERTICAL:HORIZONTAL) AT THE RAMP WHEN THE CURB AND GUTTER IS POURED BEFORE THE RAMP, OR THE GUTTER AT THE RAMP MUST BE CUT OUT, REMOVED, AND REPOURED WHEN THE RAMP IS POURED.
5. IF REQUIRED, BACK CURB HEIGHT ALONG RAMP SHALL TRANSITION FROM 0 INCHES AT EXPANSION JOINTS TO THE PROPOSED HEIGHT OF BACK CURB AT LANDING AND SHALL BE A CONSTANT HEIGHT THROUGH LANDING.
6. HIGH SIDE AND LOW SIDE RAMPS SHALL HAVE A MAXIMUM SLOPE OF 1:12 (VERTICAL:HORIZONTAL) OR SHALL BE 8 FEET (96 INCHES) MINIMUM IN LENGTH.

DATE: 07/2022

NOT TO SCALE

BRICK SIDEWALK WITH CONCRETE BASE

STANDARD DETAIL

TOWN OF CHAPEL HILL
CHAPEL HILL, TENNESSEE

DATE: 07/2022

NOT TO SCALE

STANDARD PRECAST RECTANGULAR CONCRETE CATCH BASIN

STANDARD DETAIL

TOWN OF CHAPEL HILL
CHAPEL HILL, TENNESSEE

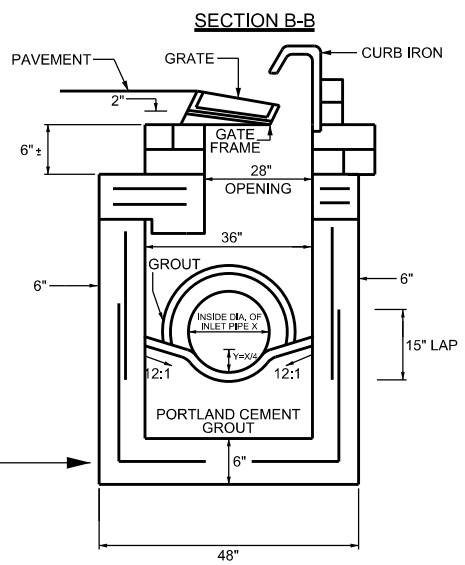
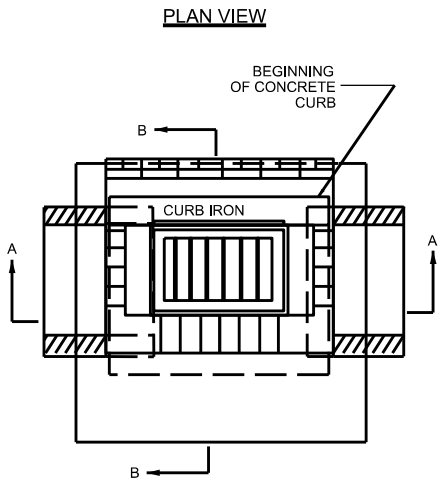
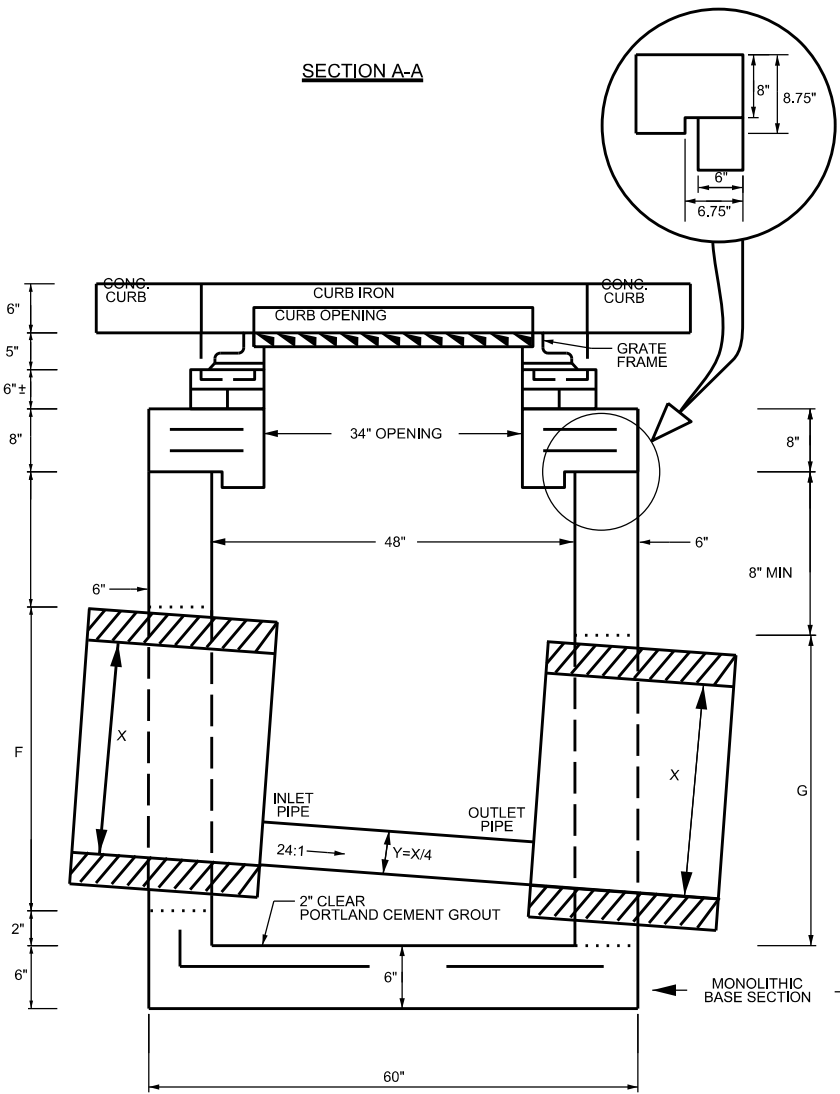

CATCH BASIN MINIMUM DEPTH TABLE			
INSIDE DIAMETER (X) OF PIPE (INCHES)	MINIMUM DEPTH - (FEET)		
	CONCRETE PIPE	CORRUGATED METAL PIPE	POLYETHYLENE PIPE
18	4.25	4.04	4.17
24	4.75	4.54	4.71
30	5.33	5.04	5.29

- ① DEPTH MEASUREMENT MADE FROM TOP OF GRATE TO OUTLET FLOW ELEVATION BASED ON INLET & OUTLET PIPES BEING THE SAME DIAMETER. IF OUTLET PIPE IS GREATER, ADJUSTMENT IN DEPTHS MUST BE MADE TO ACCOMMODATE THIS SITUATION.
- ② TO DETERMINE FLOOR OF CATCH BASIN ELEVATION, WHEN INLET & OUTLET PIPES ARE THE SAME SIZE, ADD PIPE WALL THICKNESS PLUS 1.5" TO THE ABOVE MINIMUM DEPTHS.

CUT-OUT HOLES FOR INLET & OUTLET PIPES			
INSIDE DIAMETER (X) OF PIPE (INCHES)	DIAMETER OF CUT-OUT HOLES F & G - (INCHES)		
	CONCRETE PIPE	CORRUGATED METAL PIPE	POLYETHYLENE PIPE
18	26	21	24
24	32	27	31
30	40	33	39

NOTE: REFER TO TDOT STANDARD DETAIL D-CB-12P FOR REINFORCING STEEL INFORMATION.

DATE: 07/2022

NOT TO SCALE

STANDARD PRECAST RECTANGULAR CONCRETE CATCH BASIN - NOTES

STANDARD DETAIL

TOWN OF CHAPEL HILL
CHAPEL HILL, TENNESSEE

CATCH BASIN MINIMUM DEPTH TABLE			
INSIDE DIAMETER (X) OF PIPE (INCHES)	MINIMUM DEPTH - (FEET)		
	CONCRETE PIPE	CORRUGATED METAL PIPE	POLYETHYLENE PIPE
18	4.25	4.04	4.17
24	4.75	4.54	4.71
30	5.33	5.04	5.29

- ① DEPTH MEASUREMENT MADE FROM TOP OF GRATE TO OUTLET FLOW ELEVATION BASED ON INLET & OUTLET PIPES BEING THE SAME DIAMETER. IF OUTLET PIPE IS GREATER, ADJUSTMENT IN DEPTHS MUST BE MADE TO ACCOMMODATE THIS SITUATION.
- ② TO DETERMINE FLOOR OF CATCH BASIN ELEVATION, WHEN INLET & OUTLET PIPES ARE THE SAME SIZE, ADD PIPE WALL THICKNESS PLUS 1.5" TO THE ABOVE MINIMUM DEPTHS.

CUT-OUT HOLES FOR INLET & OUTLET PIPES			
INSIDE DIAMETER (X) OF PIPE (INCHES)	DIAMETER OF CUT-OUT HOLES F & G - (INCHES)		
	CONCRETE PIPE	CORRUGATED METAL PIPE	POLYETHYLENE PIPE
18	26	21	24
24	32	27	31
30	40	33	39

NOTE: REFER TO TDOT STANDARD DETAIL D-CB-12B FOR REINFORCING STEEL INFO.

DATE: 07/2022

NOT TO SCALE

STANDARD RECTANGULAR BRICK CATCH BASIN - NOTES

STANDARD DETAIL

TOWN OF CHAPEL HILL
CHAPEL HILL, TENNESSEE

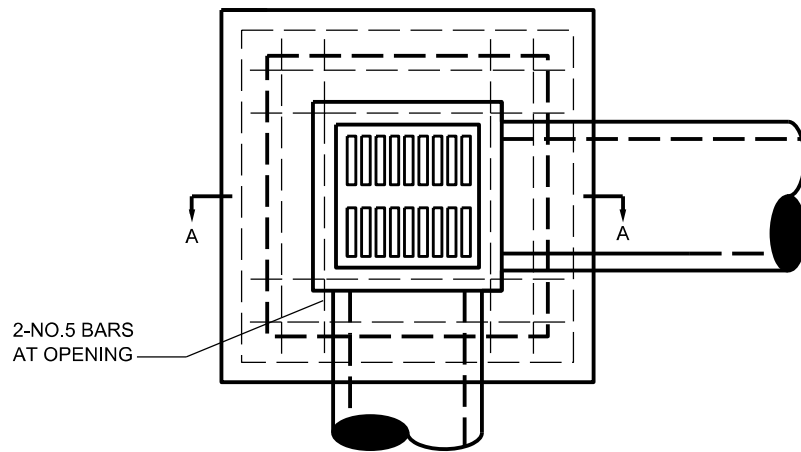

PLAN

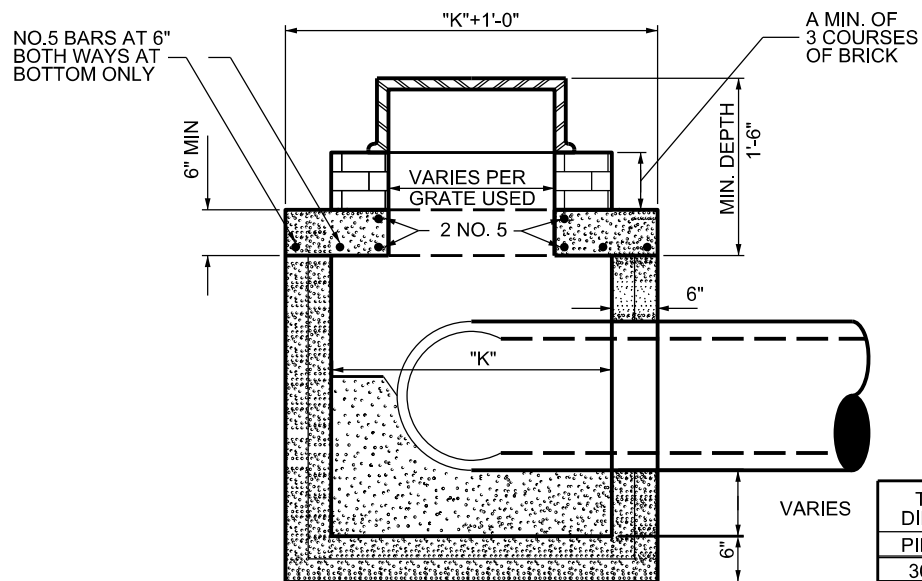

SECTION A-A

NOTES:
 FRAME AND GRATE SHOWN
 ARE FOR FLUSH MOUNTED
 INLET

TABLE OF DIMENSIONS	
PIPE	"K"
30"	4'
36"	5'
42"	6'
48"	6'
54"	7'
60"	7'
66"	8'
72"	9'

DATE: 07/2022

NOT TO SCALE

COMBINATION INLET (PRECAST)

STANDARD DETAIL

TOWN OF CHAPEL HILL
 CHAPEL HILL, TENNESSEE

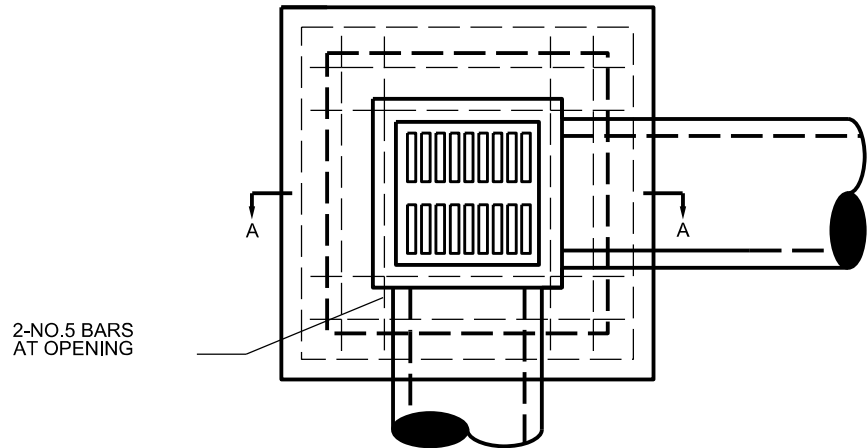

PLAN

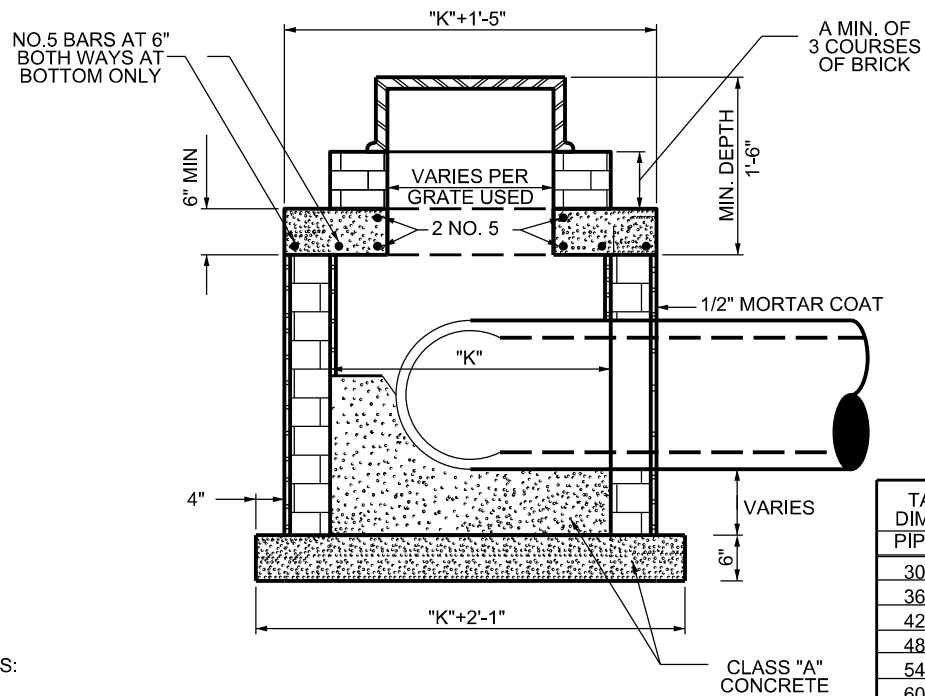

TABLE OF DIMENSIONS	
PIPE	"K"
30"	4'
36"	5'
42"	6'
48"	6'
54"	7'
60"	7'
66"	8'
72"	9'

NOTES:
 FRAME AND GRATE SHOWN
 ARE FOR FLUSH MOUNTED
 INLET

SECTION A-A

DATE: 07/2022

NOT TO SCALE

COMBINATION INLET (BRICK)

STANDARD DETAIL

TOWN OF CHAPEL HILL
 CHAPEL HILL, TENNESSEE

GRATE AND FRAME DETAILS

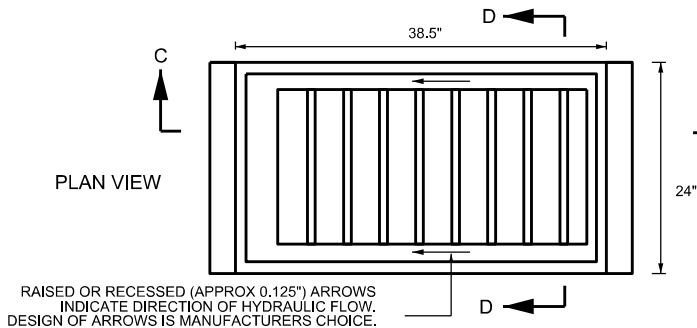

RAISED OR RECESSED (APPROX 0.125") ARROWS INDICATE DIRECTION OF HYDRAULIC FLOW. DESIGN OF ARROWS IS MANUFACTURERS CHOICE.

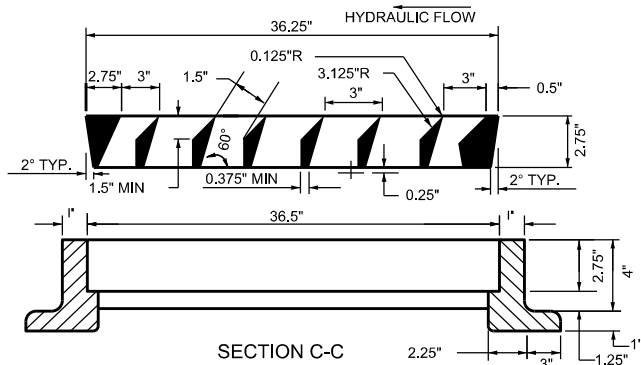

SECTION C-C

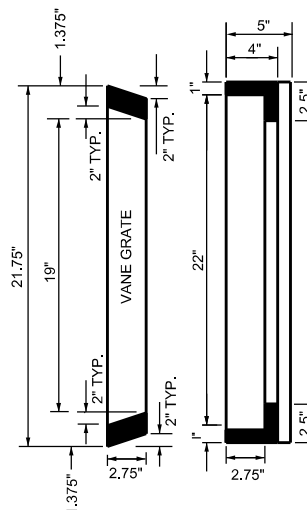

SECTION D-D

CURB INLET CASTING

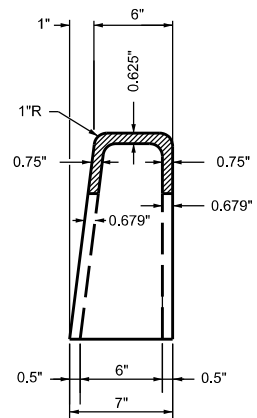
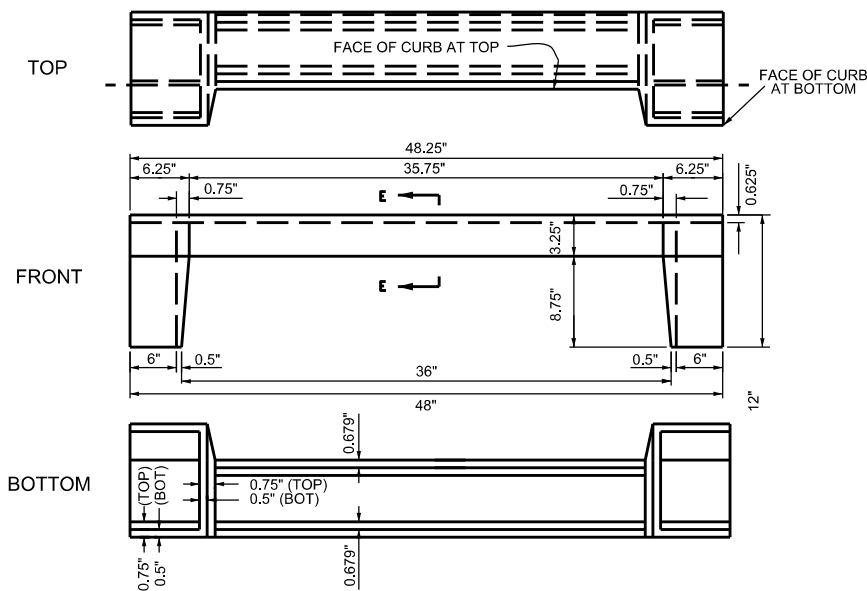

SECTION E-E

DATE: 07/2022

NOT TO SCALE

CAST IRON FRAME, GRATE & NONMOUNTABLE INLET

STANDARD DETAIL

TOWN OF CHAPEL HILL
CHAPEL HILL, TENNESSEE